

Separable Implementation of L²-Orthogonal STC CPM with Fast Decoding

Matthias Hesse¹, Jerome Lebrun¹, Lutz Lampe² and Luc Deneire¹

¹Laboratoire I3S, CNRS

University of Nice, Sophia Antipolis

Sophia Antipolis – France

e-mail: hesse,lebrun,deneire@i3s.unice.fr

²Department of Electrical and Computer Engineering

University of British Columbia

Vancouver – Canada

e-mail: lampe@ece.ubc.ca

- final version - 28.Feb.2008 -

Abstract

In this paper we present an alternative separable implementation of L^2 -orthogonal space-time codes (STC) for continuous phase modulation (CPM). In this approach, we split the STC CPM transmitter into a single conventional CPM modulator and a correction filter bank. While the CPM modulator is common to all transmit antennas, the correction filter bank applies different correction units to each antenna. Thereby desirable code properties as orthogonality and full diversity are achievable with just a slightly larger bandwidth demand. This new representation has three main advantages. First, it allows to easily generalize the orthogonality condition to any arbitrary number of transmit antennas. Second, for a quite general set of correction functions that we detail, it can be proved that full diversity is achieved. Third, by separating the modulation and correction steps inside the receiver, a simpler receiver can be designed as a bank of data independent inverse correction filters followed by a single CPM demodulator. Therefore, in this implementation, only one correlation filter bank for the detection of all transmitted signals is necessary. The decoding effort grows only linearly with the number of transmit antennas.

I. INTRODUCTION

The combination of space-time coding (STC) with continuous phase modulation (CPM) systems has attracted considerable interest. It brings the possibilities of capacity increase [1] and robustness to fading [2] in systems that display good spectral and power efficiency [3]. Pioneered by Zhang and Fitz [4], the first STC CPM constructions were based on trellis codes. This approach was also pursued by Zajić and Stüber in [5] for full response CPM, further optimized in [6] and extended to partial response CPM in [7]. Bokolamulla and Aulin [8] and Maw and Taylor [9] designed STC by splitting the CPM signal in a memoryless modulator and a continuous phase encoder (CPE) [10]. While Bokolamulla and Aulin use codes from [11], the latter combines an external encoder with the STC and the CPE. However, for these codes the decoding effort grows exponentially with the number of transmit antennas. This was partially circumvented by burst-wise orthogonality as introduced by Silvester et al. in [12] and by block-wise orthogonality as established by Wang and Xia in [13] [14]. Unfortunately, this latter design is based on the Alamouti code [15] and thus is restricted to two transmit antennas. An extension to 4 transmit antennas based on quasi orthogonal space-time codes was presented in [16].

Mainly motivated by the low complexity of decoding as described in [13] [14], our present contribution concerns orthogonal space-time block codes (STBC) for CPM systems. In our previous work [17]–[19], we have been able to design L^2 -orthogonal space-time codes for 2 and 3 transmit antennas which achieve full rate and full diversity with low decoding effort. In [17] we generalized the two-antenna code proposed by Wang and Xia [14] from pointwise to L^2 -orthogonality. In [18] we presented the first L^2 -orthogonal code family, coined *Parallel Codes* (PC), for CPM with 3 antennas.

In the present paper, we briefly review some of our previous results and generalize them to an arbitrary number of transmit antennas. More specifically, for *Parallel Codes* we present an alternative approach to the encoding by splitting the STC CPM transmitter into a conventional CPM modulator and a correction filter bank. While the modulator is shared by all transmit antennas, the correction filter bank is specific to each transmit antenna. Therefore, the correction filter bank fully characterizes the properties of the code, e.g. orthogonality, diversity and coding gain. This simple framework makes it possible to readily design L^2 -orthogonal *Parallel Codes* for an arbitrary number of transmit antennas and we prove that full diversity is achieved with these codes.

Again, by separating the demodulation and inverse correction steps at the receiver side, a simple receiver is designed as a data independent inverse correction filter bank followed by a single decorrelation unit. In this implementation, only one decorrelation unit for the detection of all transmitted CPM signals is necessary. The overall decoding effort grows only linearly with the number of transmit antennas.

The remainder of the paper is organized as follows. In Section II, we present our new code representation, show that full diversity is achieved and give a condition to obtain L^2 -orthogonality for an arbitrary number of transmit antennas. In Section III, we introduce a fast decoding algorithm for *Parallel Codes*. In Section IV, the code performance and the decoding algorithm are evaluated by simulations and finally, in Section V, we conclude this paper.

II. GENERALIZED CODE REPRESENTATION

In this section we develop a simplified representation for L^2 -orthogonal PC and prove that PC with linear phase correction functions provide full diversity. Finally, we give a condition to obtain L^2 -orthogonal codes.

A. System Model and Code Structure

Let us briefly introduce our model for the CPM transmitter with L_t transmitting antennas. We adopt the block structure from [18] and accordingly we define the CPM signal for blocks of L_t symbol intervals. The l^{th} CPM block of length $L_t T$ is given by [3]

$$s(t, \mathbf{d}) = \sqrt{\frac{E_B}{TL_t}} \exp \left(j2\pi \left[\theta(l) + h \sum_{i=lL_t-\gamma+2}^{(l+1)L_t} d_i q(t - iT) \right] \right). \quad (1)$$

for $lL_t T \leq t < (l+1)L_t T$. Here, E_B is the block energy, T is the symbol length, γ the CPM memory length, $h = m_0/p$ is the modulation index with m_0 and p relative primes and d_i is the data symbol taken from the set

$$\Omega_d = \{-M + 1, -M + 3, \dots, M - 3, M - 1\}.$$

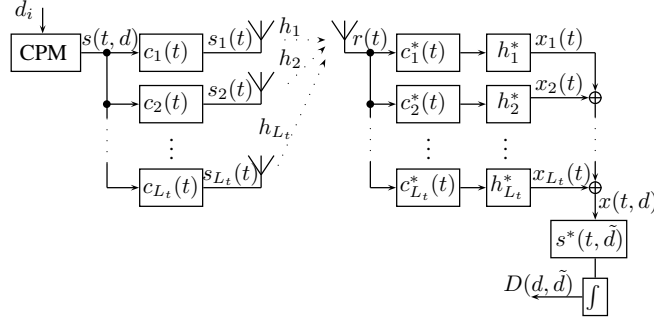

Fig. 1. Block diagram of the transmitter and receiver for STC CPM using the generalized code representation

For convenience, the data symbols of the current block l are collected in the vector $\mathbf{d} = [d_{lL_t+1} \ \dots \ d_{(l+1)L_t}]$. The phase pulse $q(t)$ is a continuous function with $q(t) = 0$ for $t \leq 0$ and $q(t) = 1/2$ for $t \geq \gamma T$ and the accumulated phase

$$\theta(l) = \frac{h}{2} \sum_{i=-\infty}^{lL_t - \gamma + 1} d_i \quad (2)$$

sums all L_t symbols reaching $1/2$ till the end of the previous block.

The family of L^2 -orthogonal codes proposed in [18] allows to send L_t CPM signals over the transmit antennas. The signal sent by each antenna is further modified by an additional correction function. Here, we present a new, generalized representation for *Parallel Codes*, a member of the L^2 -orthogonal code family. These codes use the same CPM signal $s(t, \mathbf{d})$ for each antenna and only the correction function $c_m(t)$ differs for each antenna m . Consequently, we rewrite the vector of the transmitted signals $\mathbf{s}(t, \mathbf{d})$ and obtain the new representation

$$\mathbf{s}(t, \mathbf{d}) = s(t, \mathbf{d}) \mathbf{c}(t) = s(t, \mathbf{d}) \begin{bmatrix} c_1(t) \\ \vdots \\ c_{L_t}(t) \end{bmatrix}. \quad (3)$$

Figure 1 illustrates the single CPM modulator and L_t data independent correction functions for each transmitter antenna. To maintain the constant amplitude of the CPM signal, the correction functions modify only the phase, i.e.

$$c_m(t) = \exp(j2\pi\phi_{cm}(t)), \quad (4)$$

where the design of $\phi_{cm}(t)$ will be described in the following.

B. Diversity

For convenience, we assume a receiver equipped with only one antenna but the extension to multiple antennas receivers is straightforward. The channel between the m^{th} transmitting and the receiving antenna is characterized by the channel coefficient h_m . All channel coefficients are assumed to be mutually independent, block-wise constant, Rayleigh distributed random variables. Furthermore, we assume perfect channel state information (CSI) at the

receiver and corruption by complex additive white Gaussian noise $n(t)$ (AWGN). Then the received signal follows as

$$r(t, \mathbf{d}) = \mathbf{h}^T \mathbf{s}(t, \mathbf{d}) + n(t) \quad (5)$$

$$= \begin{bmatrix} h_1 & \dots & h_{L_t} \end{bmatrix} \begin{bmatrix} c_1(t) \\ \vdots \\ c_{L_t}(t) \end{bmatrix} \mathbf{s}(t, \mathbf{d}) + n(t). \quad (6)$$

To characterize STC with linear modulations, a signal matrix \mathbf{C}_s was introduced in [2]. This matrix results from the correlation of all the possible differences of code words. To achieve full diversity, \mathbf{C}_s ought to be full rank. It was shown by Zhang and Fitz [20] that for nonlinear modulation, i.e. CPM here, the signal matrix should now be defined over waveforms, as

$$\mathbf{C}_s = \int_0^{L_t T} \mathbf{\Delta}(t) \mathbf{\Delta}^H(t) dt, \quad (7)$$

where $\mathbf{\Delta}(t)$ is the difference between two transmitted signals modulated by different data symbols \mathbf{d} and $\tilde{\mathbf{d}}$

$$\mathbf{\Delta}(t) = \begin{bmatrix} \Delta_1(t) \\ \vdots \\ \Delta_{L_t}(t) \end{bmatrix} = \mathbf{s}(t, \mathbf{d}) - \mathbf{s}(t, \tilde{\mathbf{d}}). \quad (8)$$

Proposition 1 from [20] shows that \mathbf{C}_s has full rank if and only if $\mathbf{u}^T \mathbf{\Delta}(t) \neq 0$ for all vectors $\mathbf{u} \in \mathbb{C}^{L_t}$, except $\mathbf{u} = \mathbf{0}$. This means that the waveforms of the transmitted signals have to be linearly independent. By applying Eq. (3) we obtain the diversity condition

$$\mathbf{u}^T (s(t, \mathbf{d}) - s(t, \tilde{\mathbf{d}})) \mathbf{c}(t) \neq 0. \quad (9)$$

Now, since $s(t, \mathbf{d})$ and $s(t, \tilde{\mathbf{d}})$ are different for at least one symbol, their difference is never zero for all t within a block. Thus, Eq. (9) simplifies to

$$\sum_{m=1}^{L_t} u_m c_m(t) = \sum_{m=1}^{L_t} u_m \exp(j2\pi\phi_{c_m}(t)) \neq 0, \quad (10)$$

which only depends on the correction function $c_m(t)$. A large class of functions fulfill Eq. (10). In the following, we focus only on correction functions with linear phase. Thus we define parametrized phase functions as

$$\phi_{c_m}(t) = \frac{m-1}{L_t T} \alpha t + \beta_m, \quad (11)$$

where β_m is a constant phase offset and α is a nonzero slope. Now, $\mathbf{u}^T \mathbf{c}(t) = 0$ would imply that

$$\sum_{m=1}^{L_t} (u_m \exp(j2\pi\beta_m)) \exp\left(j2\pi \frac{m-1}{L_t T} \alpha t\right) = 0 \quad (12)$$

Introducing the polynomial

$$p(x) = \sum_{m=1}^{L_t} (u_m \exp(j2\pi\beta_m)) x^{m-1}, \quad (13)$$

Eq. (12) would mean that $p(e^{j2\pi\alpha t/(L_t T)}) = 0$. This would imply that the polynomial $p(x)$, of degree $L_t - 1$, vanishes on more than L_t different points. Thus, $p \equiv 0$ and $u_m = 0$ for all m . Consequently, by [20, Prop. 1], the signal matrix \mathbf{C}_s has full rank and all the codes achieve full diversity.

The linear phase correction functions are similar to the idea of tilting phase as proposed by Rimoldi [10]. However, the purpose of tilted phase in [10] was to simplify the states of single input single output CPM systems. Here, the phase drifts are introduced to achieve L^2 -orthogonality between transmit antennas. Therefore the tilt angle (i.e. the slope of the linear phase function or the phase shift) has a quite different role in the two approaches.

C. Orthogonality

With the new representation of CPM introduced in Section II-A we derive the orthogonality condition for an arbitrary number of transmit antennas. L^2 -orthogonality is imposed by [18]

$$\begin{aligned}
 E_B \mathbf{I} &= \int_0^{L_t T} \mathbf{s}(t, \mathbf{d}) \mathbf{s}^H(t, \mathbf{d}) dt \\
 &= \int_0^{L_t T} \begin{bmatrix} c_1(t) \\ \vdots \\ c_{L_t}(t) \end{bmatrix} \begin{bmatrix} c_1^*(t) & \dots & c_{L_t}^*(t) \end{bmatrix} \underbrace{s(t, \mathbf{d}) s^*(t, \mathbf{d})}_{|s(t, \mathbf{d})|^2=1} dt \\
 &= \int_0^{L_t T} \begin{bmatrix} c_1(t) c_1^*(t) & \dots & c_1(t) c_{L_t}^*(t) \\ \vdots & & \vdots \\ c_{L_t}(t) c_1^*(t) & \dots & c_{L_t}(t) c_{L_t}^*(t) \end{bmatrix} dt \tag{14}
 \end{aligned}$$

where \mathbf{I} is the $L_t \times L_t$ identity matrix. Due to the constant amplitude of the CPM signal, orthogonality depends only on the correction functions. By Def. (4), $c_m(t) c_m^*(t) = 1$. So, we only need to cancel all the crosscorrelation terms and get

$$0 = \int_0^{L_t T} c_m(t) c_{m'}^*(t) dt \tag{15}$$

$$= \int_0^{L_t T} \exp(j2\pi[\phi_{cm}(t) - \phi_{cm'}(t)]) dt \tag{16}$$

$$= \int_0^{L_t T} \exp\left(j2\pi\left(\frac{m - m'}{L_t T} \alpha t + \beta_m - \beta_{m'}\right)\right) dt \tag{17}$$

for $m \neq m'$. To fulfill Eq. (17) we have to integrate over full rotations on the unit circle. Therefore, α needs to be an integer. In the following we set $\alpha = 1$ for two reasons:

- 1) **Minimizing bandwidth:** The correction function causes a frequency shift depending on the slope of the phase. To minimize the overall bandwidth of the system the frequency shift needs to be small. Hence, the phase slope of the correction function is required to be minimal.

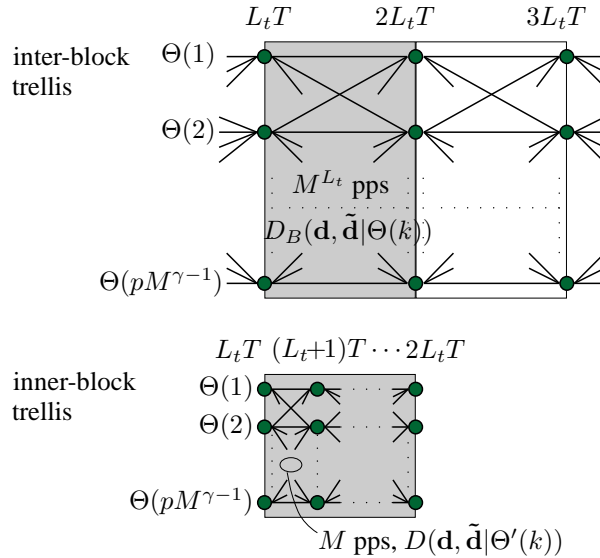

Fig. 2. Merging of inter- and inner-block trellis for simplified detection with $l = 1$ (pps - paths per state)

- 2) Equivalence to *linPC* [18]: If $\alpha = 1$ *Parallel Codes* with linear phase function coincide with the *linPC* family proposed in [18]. The phase offsets β_m in Eq. (11) correspond to the initial phases of the *linPC*.

III. FAST DECODING ALGORITHM

In this section we provide a simplified decoding scheme for the proposed parallel codes. For convenience, we assume only one receive antenna ($L_r = 1$) but the extension to multiple antennas is straightforward.

The received signal $r(t, \mathbf{d})$ is a superposition of the transmitted CPM signals which are weighted by the channel coefficients. Due to the CPM inherent continuous phase encoder (CPE) [10], the received signal consists of L_t superposing trellis codes. These are generally quite hard to decode.

To reduce the complexity of the decoder we first consider the block structure of the proposed STC. This facilitates the splitting of the super trellis into an “inter” and “inner-block” trellis as shown in Figure 2. To achieve full rate, each block contains L_t symbols with an alphabet size M which are distributed over the ST-block. Therewith each state of the inter-block trellis has M^{L_t} leaving paths, i.e. in order to calculate all block distances $D_B(\mathbf{d}, \tilde{\mathbf{d}}|\Theta(k))$, M^{L_t} matched filter of length $L_t T$ have to be applied $pM^{\gamma-1}$ times. This exponential growth of complexity with the number of transmit antennas makes the application in real world systems impossible.

Eq. (18) shows the non-simplified maximum likelihood metric for the inter-block trellis. The absolute value contains all L_t data symbols. Therefore we have to consider all crosscorrelations between the data symbols which gives us the previously mentioned M^{L_t} path metrics. By using the L^2 -orthogonality from the previous section those

correlations are canceled out and we get

$$D_B(\mathbf{d}, \tilde{\mathbf{d}}|\Theta(k)) = \int_0^{L_t T} \left| r(t, \mathbf{d}) - \sum_{m=1}^{L_t} h_m^* s^*(t, \tilde{\mathbf{d}}) c_m^*(t) \right|^2 dt \quad (18)$$

$$= \sum_{m=1}^{L_t} \int_0^{L_t T} \left| r(t, \tilde{\mathbf{d}}) - h_m s(t, \tilde{\mathbf{d}}) c_m(t) \right|^2 dt. \quad (19)$$

Here it can be seen that for nonlinear modulations, L^2 -orthogonality is sufficient to decorrelate the signals of the transmit antennas. The pointwise orthogonality of the orthogonal codes used in linear modulations is also a sufficient condition to simplify Eq. (18). But this would impose stronger restrictions upon the STC.

Eq. (19) implies that L_t conventional CPM signals have to be decoded. Hence, the complexity grows only linearly with the number of transmit antennas, i.e. due to decorrelation of the transmitted signals, each data stream from one transmit antenna can be decoded separately. Alternatively, the ML metric can be transformed into a correlation between the received signal $r(t, \mathbf{d})$ and an hypothetical version of this signal. We get an equivalent correlation based metric by

$$D_B(\mathbf{d}, \tilde{\mathbf{d}}|\Theta(k)) = \sum_{m=1}^{L_t} \int_0^{L_t T} \operatorname{Re} \left\{ r(t, \mathbf{d}) h_m^* c_m^*(t) s^*(t, \tilde{\mathbf{d}}) \right\} dt. \quad (20)$$

By splitting the correction filter $c_m(t)$ from the conventional CPM signal $s(t, \mathbf{d})$, we define a pseudo received signal as

$$x(t, \mathbf{d}) = r(t, \mathbf{d}) \sum_0^{L_t} h_m^* c_m^*(t). \quad (21)$$

This signal corresponds to a *single* preprocessed CPM signal which is decoded by

$$D_B(\mathbf{d}, \tilde{\mathbf{d}}|\Theta(k)) = \int_0^{L_t T} \operatorname{Re} \left\{ x(t, \mathbf{d}) s(t, \tilde{\mathbf{d}}) \right\} dt. \quad (22)$$

Hence, only one CPM signal has to be decoded and we obtain a single inner-block trellis which is shown at the bottom of Figure 2. The metric to compute the symbol-wise distances at time slot r is given by

$$D(\mathbf{d}, \tilde{\mathbf{d}}|\Theta'(k)) = \int_{(r-1)T}^{rT} \operatorname{Re} \left\{ x(t, \mathbf{d}) s(t, \tilde{\mathbf{d}}) \right\} dt. \quad (23)$$

This additional complexity reduction is accomplished due to the parallel structure of the proposed code. Finally, since $\alpha = 1$, the phase drift per block is always an integer ($0 \dots L_t - 1$) and therewith $c_m(0) = (c_m(L_t T))_{\text{mod } 1}$. Thus, the accumulated phase memory $\theta(l)$ at the beginning and the end of each block is defined over the same set of rational numbers, i.e. $\Omega_\theta = \{0, 1/p, \dots, (p-1)/p\}$. The states of the inner trellis at the end of one block $\Theta(k)$ and the beginning of the next $\Theta'(k)$ are consequently equal and inner and inter-block trellis can be merged to one trellis. The new block independent trellis is equivalent to the trellis of one conventional CPM signal. This is consistent with the model we use for the modulation where only one CPM signal is modulated and the signals for the different transmit antennas are created by the phase correction functions. One can look at the phase correction

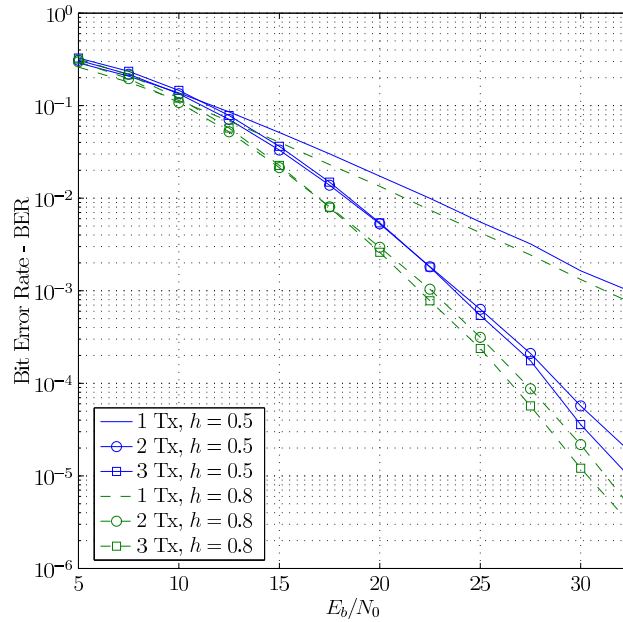

Fig. 3. BER for PC CPM with $M = 4$, 2REC, $h = 0.5$ and $h = 0.8$

filters (phasers) of the transmitter, the physical channel and the dephasers of the receiver as a single input single output pseudo channel. This pseudo channel benefits from the full diversity introduced by the correction filters whereas at the transmitter and receiver only a conventional coder and decoder are necessary.

Finally, it should be noticed that the complexity of the proposed receiver can be further decreased. Namely, methods proposed in literature ([21]) can be additionally applied to the CPM decoder.

IV. SIMULATION RESULTS

In this section, we evaluate the proposed transceiver implementation and the performance of the code by means of simulations. For all our simulations, we use a linear phase pulse with a length of $2T$ (2REC) given by $q(t) = t/4T$ for $0 \leq t \leq 2T$, $q(t) = 0$ for $t \leq 0$ and $q(t) = 1/2$ for $t \geq 2T$. An alphabet of size $M = 4$ with $\Omega_d = \{-3, -1, 1, 3\}$ is used. Further, we assume blockwise transmission with block length $L_b = 130$. The channel coefficients h_i have Rayleigh distributed amplitude and uniformly distributed phase. They are assumed to be constant during one block length $L_b T$ and the receiver has perfect knowledge of those coefficients.

As stated earlier, the complexity of the most costly part of the decoder, the MLSE, is independent of the number of transmit antennas. In our case, the trellis has always $pM = 16$ states with $M = 4$ paths originating from each state. That means that we have to evaluate only 64 path weights per symbol and $64L_t$ per block. This is valid not only for one but also for three transmit antennas. In contrast, for $L_t = 3$, a non-simplified receiver would have had to evaluate $pMM^{L_t} = 1024$ paths per ST-block. For the proposed scheme only the size of the correction filter bank grows with the number of transmit antennas. Hence, the decoding effort grows only linearly with the number of transmitting antennas. Moreover, this filter bank needs to be evaluated only once per symbol.

Figure 3 shows our simulation results for two different modulation indexes; $h = 0.5$ and $h = 0.8$. A larger modulation index increases the distance between two symbols and improves therewith the BER. The drawback of this improvement is an increased bandwidth. As expected, the simulations in Figure 3 show that the BER of the proposed STC CPM schemes also benefits from a larger modulation index. Further, the diversity gain becomes clearly visible. The slope of the BER curves increases with a growing number of transmit antennas.

For the second group of simulations ($h = 0.8$) the decoding complexity increases slightly due to the modified modulation index. The trellis has now $pM = 20$ states and we have to calculate 80 path weights per symbol. The complexity of the correction filter bank remains unchanged.

V. CONCLUSION

In this paper, we have presented a novel representation for L^2 -orthogonal *Parallel Coded* CPM. This representation decouples the data-dependent CPM modulator from the antenna-dependent correction filter bank and enables the generalization of the L^2 -orthogonal *Parallel Codes* to an arbitrary number of transmit antennas. It is also shown that these generalized codes achieve full diversity.

The main advantage of this representation arises at the receiver level. The costly maximum likelihood sequence estimation, necessary for decoding the CPM [18], is now implemented only once, independently of the number of transmit antennas. The full diversity of the system comes from the correction filter bank which is applied only once per symbol. Hence, a simplified implementation and a decoding effort that grows only linearly with the number of transmit antennas is obtained in exchange for a slightly increased bandwidth for the correction filter.

ACKNOWLEDGMENT

The work of M. Hesse is supported by a EU Marie-Curie Fellowship (EST-SIGNAL program) under contract No MEST-CT-2005-021175.

REFERENCES

- [1] I. E. Telatar, "Capacity of multi-antenna gaussian channels," *European Trans. Telecommun.*, vol. 10, pp. 585 – 595, 1999.
- [2] V. Tarokh, N. Seshadri, and A. R. Calderbank, "Space-time codes for high data rate wireless communication: Performance criterion and code construction," *IEEE Trans. Inf. Theory*, vol. 44, no. 2, pp. 744 – 765, march 1998.
- [3] J. Anderson, T. Aulin, and C.-E. Sundberg, *Digital Phase Modulation*. Plenum Press, 1986.
- [4] X. Zhang and M. P. Fitz, "Space-time coding for Rayleigh fading channels in CPM system," in *Proc. of Annu. Allerton Conf. Communication, Control, and Computing*, 2000.
- [5] A. Zajić and G. Stüber, "Continuous phase modulated space-time codes," in *Proc. of IEEE International Symposium on Communication Theory and Applications (ISCTA'05)*, July 2005, pp. 292 – 297.
- [6] —, "Optimization of coding gain for full-response CPM space-time codes," in *Proc. of IEEE Global Telecommunications Conference (GLOBECOM '06)*, Nov. 2006, pp. 1 – 5.
- [7] —, "A space-time code design for partial-response CPM: Diversity order and coding gain," in *Proc. of IEEE International Conference on Communications (ICC'07)*, June 2007, pp. 719 – 724.
- [8] D. Bokolamulla and T. Aulin, "Serially concatenated space-time coded continuous phase modulated signals," *IEEE Tran. Wireless Commun.*, vol. 6, no. 10, pp. 3487–3492, October 2007.

- [9] R. L. Maw and D. P. Taylor, "Externally encoded space-time coded systems with continuous phase frequency shift keying," in *Proc. Int. Conf. on Wireless Networks, Communications and Mobile Computing*, 2005, pp. 1597 – 1602.
- [10] B. Rimoldi, "A decomposition approach to CPM," *IEEE Trans. on Inf. Theory*, vol. 34, pp. 260 – 270, March 1988.
- [11] A. R. Hammons and H. E. Gamal, "On the theory of space-time codes for PSK modulation," *IEEE Trans. Inf. Theory*, vol. 46, pp. 524 – 542, March 2000.
- [12] A. Silvester, R. Schober, and L. Lampe, "Burst-based orthogonal ST block coding for CPM," *IEEE Trans. Wireless Commun.*, vol. 6, pp. 1208 – 1212, April 2007.
- [13] G. Wang and X.-G. Xia, "An orthogonal space-time coded CPM system with fast decoding for two transmit antennas," *IEEE Trans. Inf. Theory*, vol. 50, no. 3, pp. 486 – 493, March 2004.
- [14] D. Wang, G. Wang, and X.-G. Xia, "An orthogonal space-time coded partial response CPM system with fast decoding for two transmit antennas," *IEEE Trans. Wireless Commun.*, vol. 4, no. 5, pp. 2410 – 2422, Sept. 2005.
- [15] S. M. Alamouti, "A simple transmit diversity technique for wireless communications," *IEEE J. Sel. Areas Commun.*, vol. 16, no. 8, pp. 1451 – 1458, Oct. 1998.
- [16] G. Wang, W. Su, and X.-G. Xia, "Orthogonal-like space-time coded CPM system with fast decoding for three and four transmit antennas," in *Proc. of IEEE Global Telecommunications Conference (GLOBECOM '03)*, Nov. 2003, pp. 3321 – 3325.
- [17] M. Hesse, J. Lebrun, and L. Deneire, "L2 orthogonal space time code for continuous phase modulation," in *Proc. IEEE 9th Workshop on Signal Processing Advances in Wireless Communications SPAWC 2008*, 6–9 July 2008, pp. 401–405.
- [18] —, "Full rate L2-orthogonal space-time CPM for three antennas," in *Proc. IEEE Global Telecommunications Conference IEEE GLOBECOM 2008*, Nov. 30 2008–Dec. 4 2008, pp. 1–5.
- [19] —, "Optimized L2-orthogonal STC CPM for 3 antennas," in *Proc. Wireless Communication Systems. 2008. ISWCS '08. IEEE International Symposium on*, 21–24 Oct. 2008, pp. 463–467.
- [20] X. Zhang and M. P. Fitz, "Space-time code design with continuous phase modulation," *IEEE J. Sel. Areas Commun.*, vol. 21, pp. 783 – 792, June 2003.
- [21] J. Huber and W. Liu, "An alternative approach to reduced-complexity CPM-receivers," *IEEE J. Sel. Areas Commun.*, vol. 7, no. 9, pp. 1437–1449, Dec 1989.