

Chipless Passive Sensor for Wireless Monitoring of High Radiation Doses in Nuclear Infrastructures

Patrick Pons, Hervé Aubert, Émilie Debourg, Ayoub Rifai, Michal Olszacki, Michal Matusiak, Isabella Augustyniak, Pawel Knapkiewicz, Jan Dziuban, Denis Lavielle, et al.

► **To cite this version:**

Patrick Pons, Hervé Aubert, Émilie Debourg, Ayoub Rifai, Michal Olszacki, et al.. Chipless Passive Sensor for Wireless Monitoring of High Radiation Doses in Nuclear Infrastructures. EWSHM - 7th European Workshop on Structural Health Monitoring, IFFSTTAR, Inria, Université de Nantes, Jul 2014, Nantes, France. hal-01020337

HAL Id: hal-01020337

<https://hal.inria.fr/hal-01020337>

Submitted on 8 Jul 2014

HAL is a multi-disciplinary open access archive for the deposit and dissemination of scientific research documents, whether they are published or not. The documents may come from teaching and research institutions in France or abroad, or from public or private research centers.

L'archive ouverte pluridisciplinaire **HAL**, est destinée au dépôt et à la diffusion de documents scientifiques de niveau recherche, publiés ou non, émanant des établissements d'enseignement et de recherche français ou étrangers, des laboratoires publics ou privés.

CHIPLESS PASSIVE SENSOR FOR WIRELESS MONITORING OF HIGH RADIATION DOSES IN NUCLEAR INFRASTRUCTURES

^{1,2} P. Pons, ^{1,2} H. Aubert, ^{1,2} E. Debourg, ^{1,2} A. Rifai, ³ M. Olszacki, ³ M. Matusiak,
⁴ I. Augustyniak, ⁴ P. Knapkiewicz, ⁴ J. Dziuban, ⁵ D. Lavielle, ⁵ C. Chatry

¹ CNRS, LAAS, 7 avenue du colonel Roche, F-31400 Toulouse, France

² Univ de Toulouse, LAAS, F-31400 Toulouse, France

³ National Centre for Nuclear Research, Otwock, Poland

⁴ Wrocław University of Technology, Wrocław, Poland

⁵ TRAD, BP 47471, Labège, France

ppons@laas.fr

ABSTRACT

The dosimetry is one of the crucial techniques that are needed to assure personal safety and facilities security in the areas of high radioactivity as nuclear power plants or powerful experimental research infrastructure (LHC, XFEL, ITER). Until now, the common electronic dosimeters are based on the silicon diodes or field effect transistors what limits the measured dose value up to few Mrad, as the higher levels lead to the device saturation. The other techniques that allows for higher dose measurement (up to 100 Mrad and more) are based mostly on the variation of physic-chemical parameters of different materials but need the post measurement treatment of the sensor that has to be taken out of the monitored zone and use of the special equipment what makes the continuous measurement impossible. Moreover, in case of nuclear reactors the access to the radioactive zones is limited what leads to the measurement frequency in range of a few times per year.

The solution that may overcome that problem is the use of the recently developed innovative concept of the passive sensors that are interrogated by the radar technique. Such a solution uses the small (millimeter sized) micro-resonators designed for the ultra high frequency (about 30GHz) that are connected to the antenna and serve as its load. Any change of the resonant frequency of the resonator may be detected as the shift in the radar echo of the antenna. The sensor is interrogated by the directional radar and the reflected signal is analyzed. The associate transduction principle is that the resonator changes its resonant frequency due to the variation of the specific measured physical value like temperature, pressure or humidity. In our case, we proposed to use the known principle of Hydrogen-pressure dosimeters (HPD) where the polymer material dehydrogenates under irradiation. However, using the MEMS technology we want to miniaturize it and combine with the RF pressure transducer, in order to obtain the miniature (about 4 mm square) passive dosimeter.

The main advantages of such a system are the passive (battery less) operation mode and radar interrogation what assures the distant (few ten of meters) signal reading and real time monitoring.

KEYWORDS : *Radiation dosimeter, polymer radiolysis, MEMS.*

INTRODUCTION

The dosimetry is one of the crucial techniques that are needed to assure personal safety and facilities security in the areas of high radioactivity (10kGy – 10 MGy). Until now the existing solutions do not allow continuous monitoring as they cannot make in-situ readout.

The objective of this study is to develop an innovative concept based on miniaturized HPD (Hydrogen Pressure Dosimetry) measurement technique coupled with passive RF pressure transducers that can be interrogated wirelessly with a radar (Figure 1) [1].

The transducers principles are described in Figure 2. The irradiation will generate the outgassing of a polymer inside a micro-chamber. This overpressure leads to a deflection of a silicon membrane

that modifies the resonant frequency of the RF resonator that can be wireless interrogated thanks to a radar.

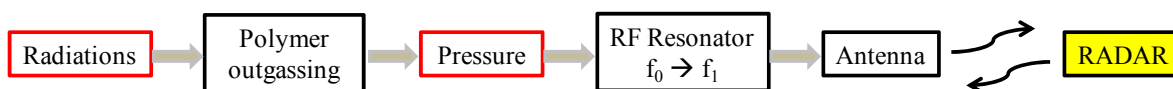

Figure 1 : Sensor principle

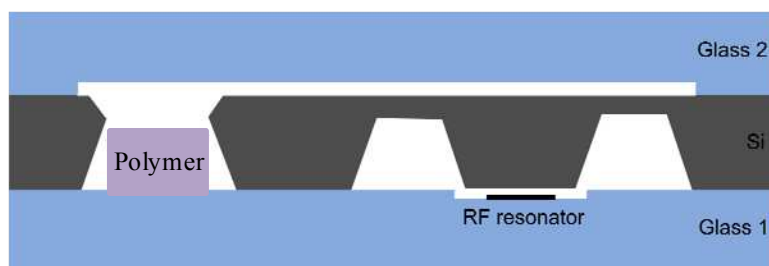

Figure 2 : Transducers principle

1 SPECIFICATIONS

In today’s world, regardless the geographical position, there are more and more facilities where high radiation doses occur, including Nuclear Power Plants (NPP) or powerful experimental research infrastructure (LHC, XFEL, ITER) [2]. Actually, the radiation levels achieved by now are small in comparison to the levels that will be achieved in the future when new generation of nuclear reactors (including nuclear fusion) or SLHC experiments will be launched. Such radiation doses cause the serious damage in the constructing materials and thus, the monitoring of the absorbed dose is crucial in order to assure the safe operation of these facilities.

According to the recent data, the typical 1GW NPP is monitored by ~ 10000 sensors, which are mostly: 2500 pressure transmitters, 150 gamma radiation monitors, 100 thermocouples and some 20 neutron detectors. The measurement equipment is basically divided into four classes: nuclear, process, radiation monitoring and special. The measured radiation doses are totally different depending on the place and purpose of measurement. Basically, five classes of radiation doses measurement are made : Personal monitoring (low doses), Coolant loop monitoring (normally low doses), Out-core infrastructure (normally low doses), In-core doses and reactor vessel structural materials (high doses), Accident measurement (extremely high doses).

The high energy physics facilities have totally different operating mode than the nuclear plants, but also the extreme high doses occurs during the experiments. We have to take into account that such facilities does not work in continuous mode what means that most of the time they are not operational. Nevertheless, the doses of radiation emitted during the colliding cycle are extreme and may last a short time. Again, monitoring of such doses is very often needed in the places where structural materials should be protected for the safety operation of the facility.

In Table 1 is listed the typical parameters that have to be addressed depending on the high doses application of the sensor.

Table1 : Dependency of main sensor parameters in a function of the application.

Application	Sensor lifecycle	Maximum Gamma dose	Accuracy	Aging effects	Neutron level
Normal NPP monitoring	2 years	20MGy	10%	Important	10^{14} n/cm ²
Accident NPP monitoring	Few days	10MGy	20%	Unimportant	0 (if no nuclear reaction)
High energy physics facilities	10-15 years	Few MGy	10%	Important	0

The solution for high dose monitoring exists widely on the market since a long time. There are a lot of methods, where most of them rely on the variation of physic-chemical parameters of the different materials : Polymer Alanine Dosimetry (PAD) , Radiophotoluminescent Dosimetry (RPLD), Hydrogen Pressure Dosimetry (HPD), Thermo Luminescent Dosimetry (TLD) [3-4]. But the main problem with all these techniques is their readout. Even if now, we have all miniaturized equipment like spectrometers or other analyzers, we cannot make the in-situ readout. All of the sensors based on different crystals need to be taken from the measurement area and the read out must be done out-of-site. The online monitoring is then impossible

2 MATERIAL STUDY

The transducer is done using 4 different materials (Figure 2) : silicon as the structural material for movable membrane, metal for passive microwave elements (resonator, antenna), glass as the structural material for microwave component holder and finally the polymer that will outgas due to the radiolysis phenomena.

2.1 Polymer

The most important material that will be used for the sensor operation is a polymer that outgases due to the radiolysis phenomenon. Due to the ionizing radiation there are some effects on polymers that include: main chain rupture, side chain rupture, crosslinking, degradation, radiolysis, oxydation. The first four effects will affect mainly the mechanical properties of the polymer and the last one can be avoid using inert atmosphere.

The radiolysis effect is generally characterized by the radiation yield G equals to number of gas molecules that are released by 1 g of polymer for the 100eV of energy absorbed due to radiation. This G factor is strongly dependant on polymer composition ($0.1 < G < 6$) and decrease generally with dose [5].

After studying publication data, we chosen High Density PolyEthylene (HDPE) as it is done in classical HPD dosimetry.

- PE has a quite high radiation yield (G between 4 to 6 depending on the composition) and G factor is energy independent what means that the amount of the released gas is dose dependent only.
- PE releases mainly hydrogen what is caused by its simple structure. Then the outgassing effect should be not affected by the interaction between other gases and no hydrocarbons will be present inside the chamber. Generally hydrocarbons have non linear response.
- Water absorption by PE is quite low (< 0.01% for HDPE)
- PE has a high decomposition temperature (about 235 °C) that is interesting for the sensor fabrication process.
- The neutron interaction should not affect a lot the radiolysis effect even if PE is a good neutron stopper (as it contains a lot of hydrogen).

- PE dissolves easily in many solvents. So it should be possible to dose it precisely by using the pipette technique, that could be useful in our case.
- PE is the most common polymer with a simple composition and is then extremely cheap.

2.2 Glass

The main effect of gamma irradiation on glass is the densification that modify the mechanical properties and can then induce additional stresses and may affect the silicon membrane deflection, the quality of silicon/glass bonding or cause cracks inside the glass. For 10 MGy gamma dose (maximum for targeted applications), Pyrex densification is around 0.04%. Most of the glasses used in microfabrication contains Boron. This element (^{10}B) reacts very easily with the thermal neutrons and then induce also material densification (0.08% for 10^{16} n/cm² thermal neutron).

Concerning RF glass properties, we analyzed the shift of resonant frequency of a mmwave planar resonator used for the transducer and fabricated on glass substrate. The resonator (Figure 3) is obtained through 1 μm thick aluminum layer deposited by PVD (Physical Vapor Deposition) on a 1mm thick Corning-Pyrex 7740 substrate. Resonators have been irradiated by high energy electron (6 MeV) with doses ranged from 11 kGy to 166 kGy and only slight variation of spectral response has been noticed.

In a first approximation, the effect of irradiation on glass can be then neglected.

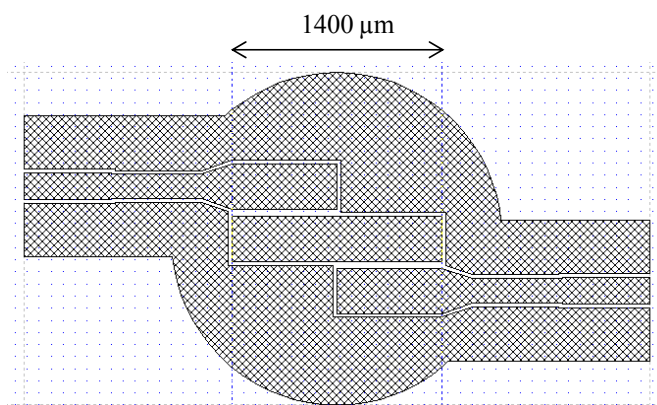

Figure 3 : Design of planar RF resonator

2.3 Silicon

Silicon, from the mechanical point of view, is highly resistant to gamma and neutron irradiation. The only effect of neutron irradiation on silicon is a transmutation to phosphorus that induces a slight variation of Young modulus.

3 TECHNOLOGICAL DEVELOPMENTS

The main critical step for the transducer fabrication concerns the silicon / glass anodic bonding with the HDPE. Indeed temperature around 450°C is generally used that is not compatible with HDPE properties.

A test structure has been designed and fabricated (Figure 4) to validate the technology. High Density PolyEthylene (HDPE) is included inside a micro-chamber fabricated with silicon / glass technology. This cavity is connected to a silicon membrane. The H₂ gas generated by irradiation will then create an over pressure inside the cavity that deflects the silicon membrane and lead to the membrane breaking.

The fabrication process is the following. A mono-crystalline n-type double-side polished (100) silicon is first etched in KOH (80°C, 10M KOH) to fabricate HDPE cavity, flow-channel and membrane. Following this, first anodic bonding is performed on back side with glass substrate (Borofloat 33, Schott) in air at 450°C, 1000 V. After that, small portion (few mg) of HDPE is precisely placed inside the cavity and cured at 180°C in N₂. Finally anodic bonding is done with top side glass (Borofloat 33, Schott) cover in pure nitrogen (1 bar) at 300°C, 1200 V. Test structures have been fabricated with different silicon membrane area (3mm x 3mm, 4mm x 4mm, 5mm x 5mm) and silicon membrane thickness around 30µm. Irradiations have been performed using high energy electron beam (6 MeV) with doses between 10kGy and 120kGy. The membrane breaking is obtained around 100kGy for 3mm x 3mm area, 80kGy for 4mm x 4mm area and 35kGy for 5mm x 5mm area. These results are consistent with analytical model of membrane breaking and validate two main points that are the hermetic sealing of the cavity at low temperature with HDPE and the strong outgasing of HDPE under irradiation [2].

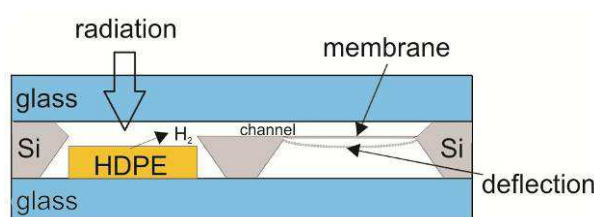

Figure 4 : Schematics of first test structure

4 TRANSDUCER DEVELOPMENTS

4.1 HDPE outgasing

Taking into account hydrogen out-gasing sensitivity around 4.10^{-7} mole / g_{HDPE} / kGy (G factor equal to 4), the under pressure P_g generated inside the micro-chamber (Volume V_c , internal pressure 1 bar) is given by relation 1 :

$$P_g \text{ (bar)} \cong 10^{-2} \frac{V_{HDPE}}{V_c} / kGy \quad (1)$$

where V_{HDPE} is the HDPE volume (HDPE density equal to 0.95mg/mm^3).

For a typical HDPE volume (between 1 mm^3 and 10 mm^3), it is then possible to obtain under pressure around few bars for a large range of radiation dose (Table 2). The minimum V_c volume is limited by the accuracy of the HDPE cavity filling ($V_c < V_{HDPE} / 10$). On the contrary, small V_{HDPE}/V_c ratio are not difficult to obtain as we have just to reduce the HDPE cavity and increase the micro-chamber surface. Pressure around few bars is useful for the full dose range as the pressure is high enough to reduce the mechanical parasitic effects and low enough to be compatible with simple micro-structure.

Table 2 : Typical ratio volume for different dose range giving few bar under pressure

Dose range	V_{HDPE} / V_c	P_g (bars)
10 kGy	10	1
100 kGy	5	5
1 MGy	0,5	5
10 MGy	0,05	5

4.2 Test structure

Test structures have been designed in order to measure the silicon membrane deflection with an optical profiler after irradiation (Figure 5). Boss membrane has been chosen as it allows easier membrane deflection measurement and provides a quasi- uniform membrane displacement that will optimize the RF transducer sensitivity.

The process used is similar to the process described in §3. The cavity depth in glass1 and the membrane thickness have been fixed respectively to 10µm and 50µm.

With the dimensions described previously, the volumes of HDPE micro-cavity (V_{HDPE}) and cavity chamber (V_c) are equal respectively to 8.8mm³ and 0.7mm³. Figure 6 gives the expected under pressure P_g generated for different ratio of HDPE cavity filling. The maximum volume of HDPE is a little bit lower than 8.8mm³ (around 7.7mm³) as the 50µm depth silicon channel reduce this potential volume. As it is also difficult to fill completely the HDPE cavity, a reasonable cavity filling between 25% and 50% is expected, that will give an overpressure between 0.3bar and 1bar for 100kGy. This overpressure leads to a membrane deflection between 1µm and 3µm that is high enough for easy measurements.

Irradiations on test structures are in progress and results will be given during the conference.

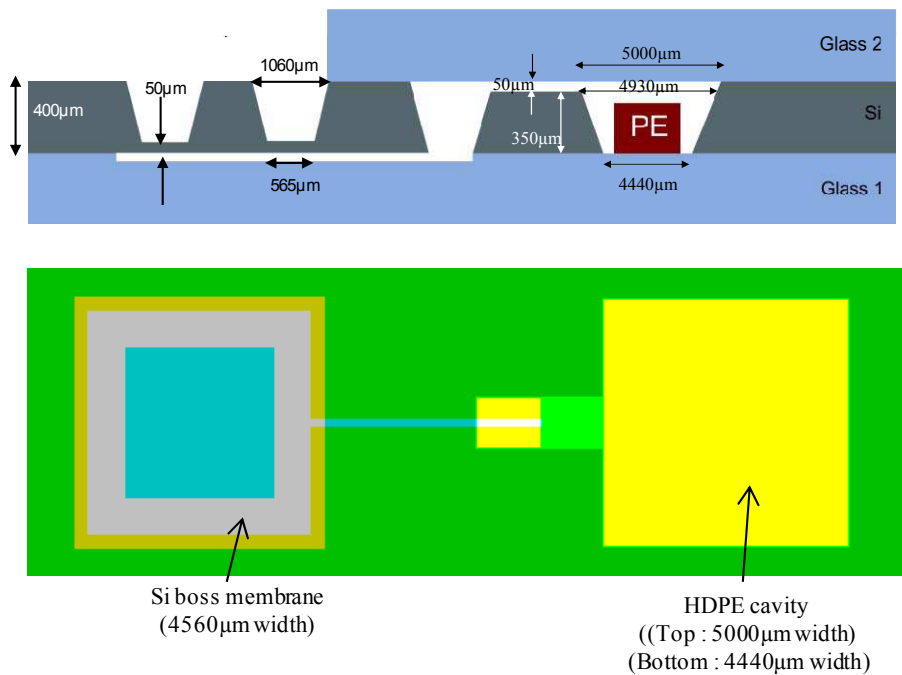

Figure 5 : Test structure with boss silicon membrane
 Top : cross section drawing, Bottom : mask view

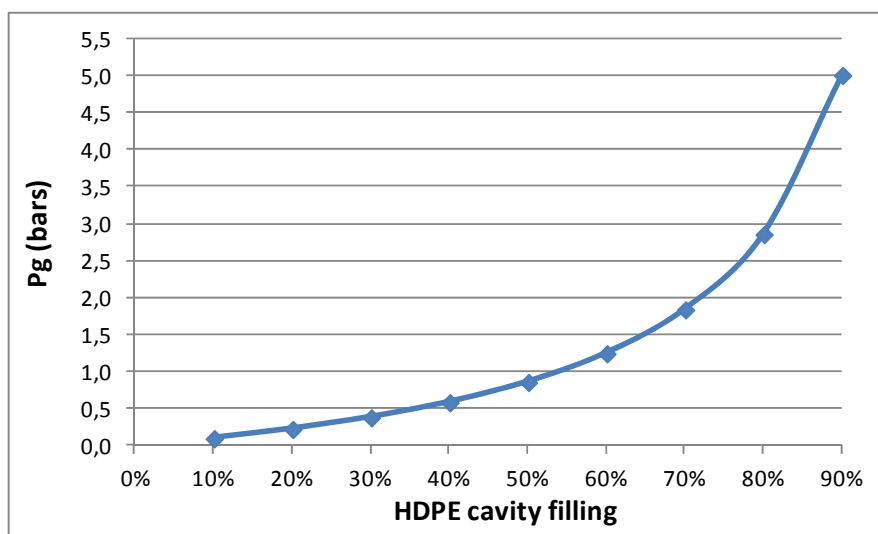

Figure 6 : Expected under pressure P_g generated for different ratio of HDPE cavity filling and for 100kGy

CONCLUSION

The first prototypes of miniature cavity with integrated polymer have been fabricated and the principle of hydrogen outgasing has been validated by silicon membrane breaking under over pressure. The ongoing works are focused on the polymer outgasing sensitivity using silicon membrane deflection. The next step will be the integration of hydrogen micro-cavity and MEMS pressure sensor.

ACKNOWLEDGEMENTS

This work was done in the framework of FP7-MNT-ERA.NET-DOSIMEMS project funded by EU via Foundation for Polish Science and by Midi-Pyrénées Region.

REFERENCES

- [1] M. Jatlaoui, F. Chebila, P. Pons, H. Aubert : Working Principle Description of the Wireless Passive EM Transduction Pressure Sensor, *European Physical Journal - Applied Physics*, Vol 56, N°1, oct 2011
- [2] International Atomic Energy Agency, "Nuclear Security Report", 5 September, 2011
- [3] K. Brabcová, I. Jadrníková, A. G. Molokanov : Dosimetry in Heavy Ion Beams Using Various Detectors, *Radiation Measurements*, vol. 45, pp. 1384-1386, 2010.
- [4] F. Ravotti, M. Glaser, A. B. Rosenfeld : Radiation Monitoring in Mixed Environments at CERN: From the IRRAD6 Facility to the LHC Experiments, *IEEE Transactions on Nuclear Science*, vol. 54, pp. 1170-1177, 2007.
- [5] E.M. Kinderman, S.B. Radding : Nuclear Radiation Effects on Structural Plastics and Adhesives, *Astia Document*, June 1957
- [6] I. Augustyniak, P. Knapkiewicz, J. Dziuban, M. Matusiak, M. Olszacki, P. Pons : MEMS high-doses radiation sensor, *International Conference on Solid State Sensors, Actuators and Microsystems (Transducers)*, June 16-20 2013, Barcelona, Spain