

A General SDN-based IoT Framework with NVF Implementation

Jie Li, Eitan Altman, Corinne Touati

► **To cite this version:**

Jie Li, Eitan Altman, Corinne Touati. A General SDN-based IoT Framework with NVF Implementation. ZTE Communications, ZTE Corporation, 2015, 13 (3), pp.42-45. hal-01197042

HAL Id: hal-01197042

<https://hal.inria.fr/hal-01197042>

Submitted on 11 Sep 2015

HAL is a multi-disciplinary open access archive for the deposit and dissemination of scientific research documents, whether they are published or not. The documents may come from teaching and research institutions in France or abroad, or from public or private research centers.

L'archive ouverte pluridisciplinaire **HAL**, est destinée au dépôt et à la diffusion de documents scientifiques de niveau recherche, publiés ou non, émanant des établissements d'enseignement et de recherche français ou étrangers, des laboratoires publics ou privés.

A General SDN-based IoT Framework with NFV Implementation

Jie Li¹, Eitan Altman², and Corinne Touati^{2,3}

¹Faculty of Engineering, Information and Systems

University of Tsukuba, Japan. Email: lijie@cs.tsukuba.ac.jp

²Inria, France. Email: {Eitan.Altman, Corinne.Touati}@inria.fr

³CNRS, LIG, University Grenoble Alpes, France.

Abstract

The emerging technologies of IoT (Internet of Things), SDN (Software Defined Networking), and NFV (Network Function Virtualization) have great potential for the information service innovation in the Cloud and big data era. In this paper, we study the architecture models of IoT, SDN with NFV implementation. We present a general SDN-based IoT framework with NFV implantation in order to take advantages of SDN and NFV and help for the design of IoT architecture.

1 Introduction

The Internet of Things (IoT) is a paradigm that is rapidly gaining ground in the scenario of modern wireless telecommunications. The basic idea is the pervasive presence around us of a variety of smart things or devices such as Radio-Frequency IDentification (RFID) tags, sensors, actuators, smart mobile phones through unique addressing schemes which are able to interact with each other and cooperate with their neighbors to reach common goals in an intelligent way [1]. Advancement in wireless networking has let these thousands of smart devices connect to the Internet anywhere and anytime. With the development of IoT, the amount of data produced per day increases exponentially [1], [3]. Nowadays we are also in the Cloud computing and big data era in which most of computing and communication resources are shared and provided to users. The characteristics of diversity, dynamics, and

big data explosion bring a big challenge for the design of the IoT architecture in the Cloud and big data era. Networks should now be more intelligent, more powerful, more efficient, more secure, more reliable, and more scalable to meet the requirements of the characteristics of diversity and dynamics. We believe that the Software Defined Networking (SDN) [9] and Network Functions Virtualization (NFV) [6], [11] are two promising technologies that could help to address these challenges and leverage the IoT architecture in the Cloud era. In this paper, we present a general SDN-based IoT framework with NFV implementation for the IoT architecture design.

The rest of the paper is organized as follows. Section 2 presents the IoT architecture model. Section 3 presents the concepts of SDN and NFV and the design problems. Section 4 presents a general SDN-based IoT framework with NFV implementation. Section 5 concludes the paper.

2 The IoT Architecture Model

To understand IoT, it is important to have the IoT architecture model in mind. Several interesting IoT architecture models have been proposed, e.g., [2], [5], [1]. These exiting IoT architecture models focus on different application aspects related to IoT. In this paper, we want to study the impacts of SDN and NFV on the IoT architecture. We layer the IoT architecture into Service Layer, Network Layer, and Sensing Layer based on [2] [5] as shown in Fig. 1. The Service Layer provides information services according to the user and system requirements. The Service Layer may include powerful data centers and different data servers for the data mining, analysis, processing, storage, and applications. The Network Layer includes the gateway and the routes for the data transmission from gateways to different application users. The Sensing Layer includes sensing devices such as sensors, actuators, and RFID (Radio Frequency Identifier). These devices are usually not expensive but smart enough for sensing. They sense and collect data from different physical, human, and natural worlds in an intelligent and collaborative way, and temporarily store the collected data in the devices with small amount of memory. The collected data are then transmitted to the gateway which is done usually by wireless transmission using MQTT (Message Queue Telemetry Transport) protocol or HPTT (Hypertext Transfer) protocol. Since the amount of sensed and collected data may be large, the data compression and aggregation methods may be used for the

efficient data transmission.

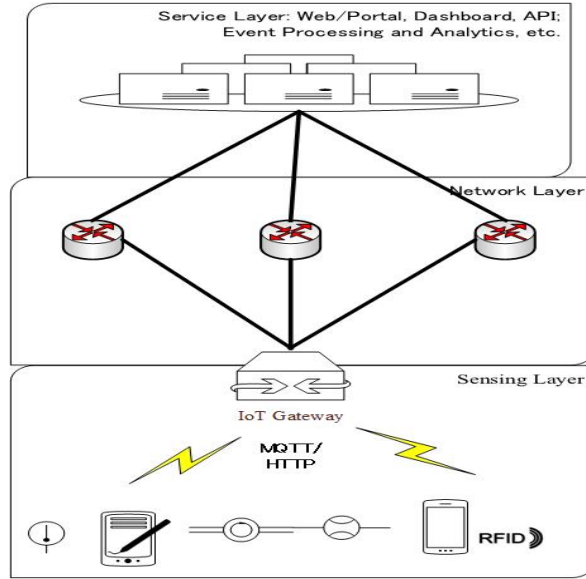

Figure 1: IoT Architecture

3 SDN and NVF Overview

Software Defined Networking (SDN) [17], [7], [8] is a novel networking paradigm separating the system that makes decisions about where traffic is sent (the control plane) from the underlying system that forwards traffic to the selected destination (the data plane). In traditional routers and switches, the control and data planes are in one device. The separation of control plane and data plane enables network more flexibility, manageability, and adaptability for the high-bandwidth, dynamic nature for today's applications [9]. The Open Networking Foundation (ONF) [9] takes the leading role in SDN standardization, and has defined an SDN architecture model as depicted in Fig. 2. In the SDN architecture model, there are Application Layer, Control layer, and Infrastructure Layer. The Application Layer consists of the end-user business applications that consume the SDN communications services. The Control Layer consists of SDN controllers which belong to the control plane. It provides the logically centralized control functionality that supervises the network forwarding behavior through an open interface. The Infrastructure Layer consists of the network elements (NE) and devices such as switches and routers which belong to the data plane. It provides packet switching

and forwarding.

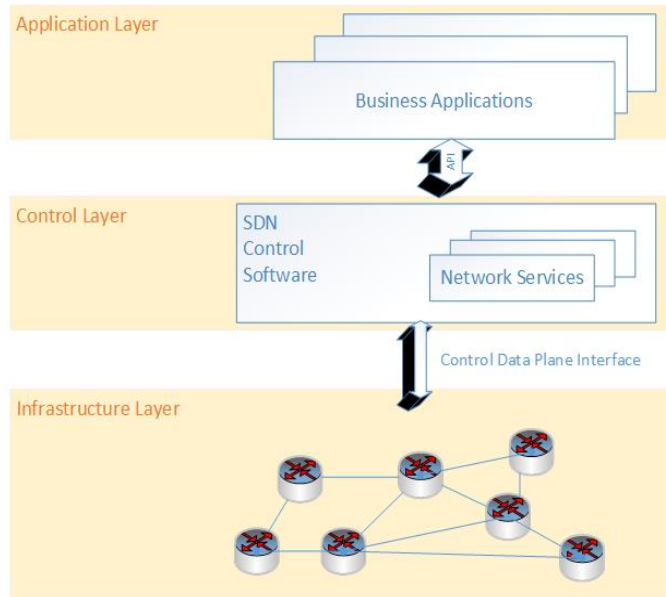

Figure 2: SDN Architecture

Network function virtualization (NFV) [6], [11] is a network architecture concept that proposes using IT virtualization related technologies to virtualize entire network functions into building blocks that may be connected, or chained, to create communication services. A virtualized network function may consist of one or more virtual machines running different applications and processes in network servers, switches, storage, or even cloud computing infrastructure, instead of having custom hardware appliances for each network function.

Introduction of both NFV and SDN to the IoT framework could leverage the network efficiency and attain the programmability and flexibility of networks [10], [11], [18]. For example, using the OpenFlow-based SDN (SDN-OF) technologies with NFV implementation, it is possible to implement the IoT networking functions such as routing, access control in Firewall, secure tunnel between IoT gateway and utility server in IPSec protocol, and prioritizing critical/control traffic for QoS in a centralized programmable controller [18]. Fig. 3 shows a network architecture with conventional IoT gateways. Fig. 4 shows network architecture using SDN-OF and NFV technologies. It is believed that through such network function virtualization for the SDN-based IoT framework, the efficiency and the network agility of IoT could be leveraged significantly.

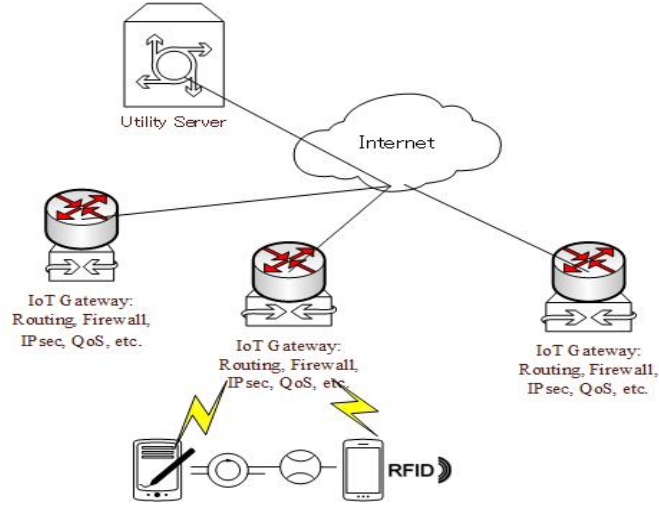

Figure 3: Network Architecture with Conventional IoT Gateway

4 A General SDN-based IoT Framework with NFV Implementation

In the SDN architecture, the controller plays a key role. It deals with networking services such as routing, firewall, load balancing, QoS, charging for the whole network. A centralized controller for a network can take advantage of global view and control of the whole network which is a desirable characteristics for the system implementation and development. It is clear that a centralized controller cannot provide all the networking services if the network size becomes large [4], [20]. Hu *et al.* [4] provides a survey about some types of controllers and the methods to enhance controllers' performance. Xavier and Seol [20] briefly mention that placement of controllers in a SDN network can be centralized, physically distributed, hierarchically distributed, and logically distributed. Kang *et al.* [7] presents a rule-placement algorithm that distribute data forwarding policies while managing rule-space constraints across general SDN networks in a logically centralized way. Voellmy *et al.* [19] presents efficient programming model to design algorithms for the SDN control. An interesting idea about the SDN-based framework combing 4G cellular networks for machine-to-machine communications is presented in [17]. The proposed framework depends on the specific 4G cellular network architecture. An extended Multinetwork INformation Architecture (MINA) with layered SDN controller is proposed for IoT [15]. However, these existing works have not studied the general IoT architecture using SDN and NFV.

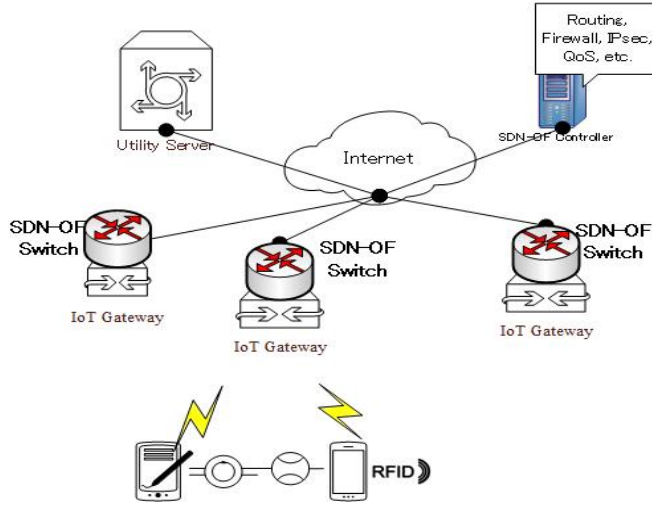

Figure 4: Network Architecture using SDN-OF and NFV Technologies

Based on the study on the IoT architecture, SDN architecture, NFV, and the example shown in Fig. 4, we have a general SDN-based IoT framework with NFV implementation as shown in Fig. 5. In the framework, the Application Layer consists of the IoT servers for different IoT applications and services through APIs. The Control Layer consists of SDN controllers run by distributed OS (Operating System). The distributed OS provides a logically centralized control and view over IoT in a physically distributed network environment for the network data forwarding. The Infrastructure Layer consists of the IoT gateways combined with SDN switches for the access to different IoT devices such as RFIDs and sensors through control data plane interface. It can be seen as an extension of the SDN architecture for IoT.

In the general framework, we want to emphasize the importance of designing an efficient distributed OS for the SDN-based IoT. The key component of the general SDN-based IoT framework is the distributed OS in the control plane. It takes the role of the brain of SDN-based IoT with NFV implementation. With such distributed OS for the SDN-based IoT framework, it is possible to provide a centralized control and visibility of different IoT services for different IoT users. Nowadays, the big challenging issue is to design and implement an efficient distributed OS for the general SDN-based IoT framework. It is because of the diversity and dynamics of different users and infrastructures in IoT. Recently, many SDN associations, such as OpenFlow and ONF, try to mitigate the challenging issue by standardization of associated APIs. An interesting proposal for providing a lightweight portability layer for the SDN

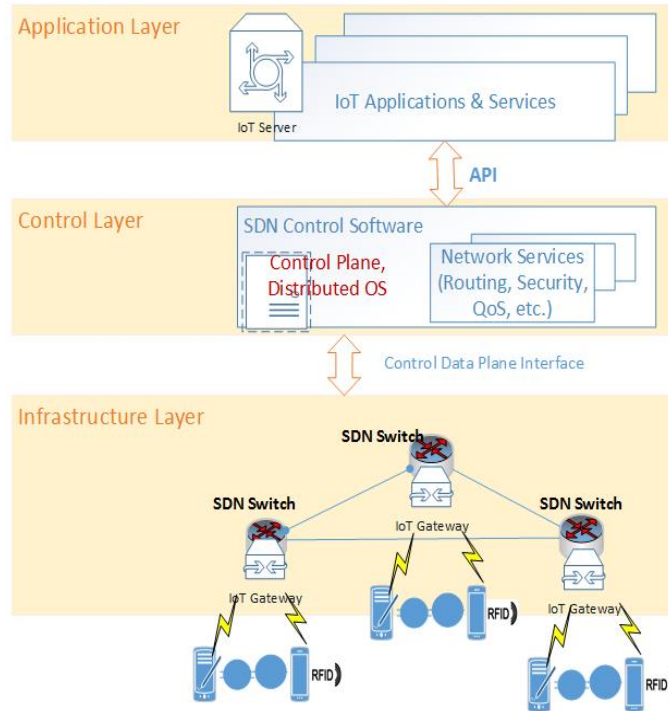

Figure 5: A General SDN-based IoT Framework with NFV Implementation

OS, NOSIX [16], has been proposed to achieve the portability and performance across different SDN switches. The ONOS (Open Network Operating System) project [12] has started to release the basic SDN-based distributed OS. The important issues of the SDN control plane performance, scalability, and availability have been addressed in [13], [14]. The design and implementation of efficient distributed OS for the SDN-based IoT are ongoing.

5 Conclusion

The emerging technologies of IoT, SDN, and NFV have great potential for the information service innovation in the Cloud and big data era. The decoupling of the control plane from the data plane in SDN architecture provides IoT users with a centralized system view and control over IoT. On the other hand, the design of efficient SDN-based IoT architecture with NFV implementation is a big technical challenge. In this paper, we provide a brief up-to-date overview of the IoT architecture model, SDN, and NFV. We study the characteristics of these emerging technologies. A general SDN-based IoT framework with NFV implantation is presented. As a future work, we will study the organization and components of each part in

the SDN-based IoT framework.

References

- [1] Luigi Atzori, Antonio Iera, Giacomo Morabito, "The Internet of Things: A survey," *Computer Networks*, vol. 54, issue 15, pp. 2787-2805, October 2010.
- [2] *A Reference Architecture for the Internet of Things*, WSO2 White Paper, <http://wso2.com>
- [3] D. Giusto, A. Iera, G. Morabito, L. Atzori (Eds.), *The Internet of Things*, Springer, 2010.
- [4] F. Hu, Q. Hao, and K. Bao, "Survey on Software-Defined Network and OpenFlow: From Concept to Implementation," *IEEE Communications Surveys & Tutorials*, vol. 16, issue 4, pp. 2181 - 2206, May 2014.
- [5] *Internet of Things - Architecture*, IoT-A, <http://www.iot-a.eu/public>
- [6] R. Jain, S. Paul, "Network virtualization and software defined networking for cloud computing: a survey," *IEEE Communications Magazine*, vol. 51, issue 11, pp. 24 - 31, November 2013.
- [7] N. Kang, Z. Liu, J. Rexford, and D. Walker, "Optimizing the gOne Big Switchh Abstraction in Software-Defined Networks," *Proc. of the 9th International Conference on emerging Networking EXperiments and Technologies (CoNEXT)*, pp. 13 - 24, Santa Barbara, CA, USA, December 9-12, 2013.
- [8] D. Kreutz, F. M. V. Ramos, P. Verissimo, C. Rothenberg, S. Azodolmolky, S. Uhlig, "Software-Defined Networking: A Comprehensive Survey," <http://arxiv.org/abs/1406.0440>, in submission, 2015.
- [9] Open Networking Foundation, *SDN Architecture*, Issue 1, ONF TR-502, June 2014.
- [10] Open Networking Foundation, *SDN in the Campus Environment*, September 30, 2013.
- [11] Open Networking Foundation, *OpenFlow-enabled SDN and Network Functions Virtualization*, February 2014.

- [12] Open Network Operating System Project <http://onosproject.org/>
- [13] "Raising the bar on SDN control plane performance and scalability," *ONOS White paper*, April 6, 2015. <http://onosproject.org/wp-content/uploads/2014/11/Whitepaper-ONOSBlackbirdperformance-generalaudience-Apr-7.pdf>
- [14] "Raising the bar on SDN control plane performance, scalability, and high availability," *ONOS Technical White paper*, April 6, 2015. <http://onosproject.org/wp-content/uploads/2014/11/PerformanceWhitepaperBlackbirdrelease-technical.pdf>
- [15] Z. Qin, G. Denker, C. Giannelli, P. Bellavista, N. Venkatasubramanian, "A Software Defined Networking architecture for the Internet-of-Things," *Proc. of the 2014 IEEE Network Operations and Management Symposium (NOMS)*, pp. 1-9, Krakow, Poland, May, 2014.
- [16] M. Raju, A. Wundsam, M. Yu, "NOSIX: A Lightweight Portability Layer for the SDN OS," *ACM SIGCOMM Computer Communication Review*, vol. 44, no.2, pp. 29-35, April 2014.
- [17] G. Savarese, M. Vaser, and M. Ruggieri: "A Software Defined Networking-based Context-Aware Framework Combining 4G Cellular Networks with M2M," *Proc. of the 2013 16th International Symposium on Wireless Personal Multimedia Communications*, pp. 1-6, Atlantic City, NJ, USA, June, 2013.
- [18] V.R. Tadinada, "Software Defined Networks: Redefining the Future of Internet in IoT and Cloud Era," *Proc. of 2014 International Conference on Future Internet of Things and Cloud*, pp. 296-301, 27-29 Aug. 2014.
- [19] A. Voellmy, J. Wang, Y.R. Yang, B. Ford, P. Hudak, "Maple: Simplifying SDN Programming Using Algorithmic Policies," *Proc. of ACM SIGCOMM 2013*, pp. 87 - 98, Hong Kong, China, August 12-16, 2013.
- [20] H.F. Xavier and S. Seol, "A Comparative Study on Control Models of Software-Defined Networking (SDN)," *Contemporary Engineering Sciences*, vol. 7, no. 32, pp. 1747 - 1753, 2014.