

An equivariant rim hook rule for quantum cohomology of Grassmannians

Elizabeth Beazley, Anna Bertiger, Kaisa Taipale

► **To cite this version:**

Elizabeth Beazley, Anna Bertiger, Kaisa Taipale. An equivariant rim hook rule for quantum cohomology of Grassmannians. Louis J. Billera and Isabella Novik. 26th International Conference on Formal Power Series and Algebraic Combinatorics (FPSAC 2014), 2014, Chicago, United States. Discrete Mathematics and Theoretical Computer Science, DMTCS Proceedings vol. AT, 26th International Conference on Formal Power Series and Algebraic Combinatorics (FPSAC 2014), pp.23-36, 2014, DMTCS Proceedings. <hal-01207588>

HAL Id: hal-01207588

<https://hal.inria.fr/hal-01207588>

Submitted on 1 Oct 2015

HAL is a multi-disciplinary open access archive for the deposit and dissemination of scientific research documents, whether they are published or not. The documents may come from teaching and research institutions in France or abroad, or from public or private research centers.

L'archive ouverte pluridisciplinaire **HAL**, est destinée au dépôt et à la diffusion de documents scientifiques de niveau recherche, publiés ou non, émanant des établissements d'enseignement et de recherche français ou étrangers, des laboratoires publics ou privés.

An equivariant rim hook rule for quantum cohomology of Grassmannians

Elizabeth Beazley¹, Anna Bertiger², Kaisa Taipale³

¹*Department of Mathematics and Statistics, Haverford College, Haverford, PA, USA*

²*Department of Combinatorics and Optimization, University of Waterloo, Waterloo, Ontario, Canada*

³*Department of Mathematics, University of Minnesota, Minneapolis, MN, USA*

Abstract. A driving question in (quantum) cohomology of flag varieties is to find non-recursive, positive combinatorial formulas for expressing the quantum product in a particularly nice basis, called the Schubert basis. Bertram, Ciocan-Fontanine and Fulton provide a way to compute quantum products of Schubert classes in the Grassmannian of k -planes in complex n -space by doing classical multiplication and then applying a combinatorial rimhook rule which yields the quantum parameter. In this paper, we provide a generalization of this rim hook rule to the setting in which there is also an action of the complex torus. Combining this result with Knutson and Tao’s puzzle rule provides an effective algorithm for computing the equivariant quantum Littlewood-Richardson coefficients. Interestingly, this rule requires a specialization of torus weights that is tantalizingly similar to maps in affine Schubert calculus.

Résumé. Une question importante dans la cohomologie quantique des variétés de drapeaux est de trouver des formules positives non récursives pour exprimer le produit quantique dans une base particulièrement bonne, appelée la base de Schubert. Bertram, Ciocan-Fontanine et Fulton donnent une façon de calculer les produits quantiques de classes de Schubert dans la Grassmannienne de k -plans dans l’espace complexe de dimension n en faisant la multiplication classique et appliquant une règle combinatoire “rimhook” qui donne le paramètre quantique. Dans cet article, nous donnons une généralisation de ce règle rimhook au contexte où il y a aussi une action du tore complexe. Combiné avec la règle “puzzle” de Knutson et Tao, cela donne un algorithme effectif pour calculer les coefficients équivariants de Littlewood-Richard. C’est intéressant à observer que cette règle demande une spécialisation des poids du tore qui est similaire d’une manière tentante aux applications dans le calcul de Schubert affine.

Keywords: Schubert calculus, quantum equivariant cohomology, rim hook, abacus diagram, factorial Schur function

1 Introduction

Quantum cohomology grew out of explorations in string theory in the early 1990s. The proposal by Candelas, de la Ossa, Green, and Parkes of a partial answer to the Clemens conjecture regarding the number of rational curves of given degree on a general quintic threefold brought enormous attention to the mathematical ideas being used by these physicists. A mathematical formulation of quantum cohomology was soon developed. In the mid-1990s Givental proved the result proposed by the physicists and simultaneously introduced, with Kim, equivariant Gromov-Witten invariants, [Giv96, GK95, FP97]. The quantum cohomology ring of the Grassmannian of k -dimensional planes in \mathbb{C}^n , denoted $Gr(k, n)$, is particularly

pleasant and combinatorial, and this project extends some of the beautiful tools of combinatorics to an easier method for computing equivariant quantum Littlewood-Richardson (EQLR) coefficients.

(Small) quantum cohomology is a deformation of classical cohomology by the quantum parameter q , and the Schubert basis elements σ_λ in $H^*(Gr(k, n))$ miraculously still form a basis for both the quantum and equivariant quantum cohomology of the Grassmannian. The Borel isomorphism can then be generalized and allows us to consider quantum cohomology as an algebra of Schur functions. Bertram, Ciocan-Rontanine and Fulton [BCFF99] showed how to carry out quantum multiplication in $QH^*(Gr(k, n))$, and thus compute quantum Littlewood-Richardson numbers, in terms of Schur functions. Mihalcea then proved the analog of the classical positivity results for EQLR coefficients [Mih06] and also provided a ring presentation for $QH_T^*(Gr(k, n))$ [Mih08]. In that paper, Mihalcea showed that the factorial Schur polynomials of [MS99] represent the Schubert classes in $QH_T^*(Gr(k, n))$, in addition to representing the Schubert classes in $H_T^*(Gr(k, n))$.

The key idea which motivates this work is the observation of [BCFF99] that quantum multiplication should be expressible in terms of multiplication of Schur polynomials in k variables. Classically, Littlewood-Richardson coefficients are the non-negative constants which determine how the product of two Schubert classes $\sigma_\lambda, \sigma_\mu$ in $H^*(Gr(k, n))$ expands in terms of the Schubert basis:

$$\sigma_\lambda \cdot \sigma_\mu = \sum_{\nu} c_{\lambda, \mu}^{\nu} \sigma_{\nu}. \quad (1.1)$$

In [BCFF99], Bertram, Ciocan-Fontanine, and Fulton proved an explicit formula for the quantum version of these Littlewood-Richardson coefficients as signed summations of the classical coefficients $c_{\lambda, \mu}^{\nu}$. The algorithm involves removing certain *rim hooks* from the border strip of the tableaux ν in exchange for picking up signed powers of the quantum variable q , and thus became known as the *rim hook rule*. The main theorem in this paper generalizes the rim hook rule to the equivariant setting. The following result appears as Theorem 2.2 in the body of this paper.

Main Theorem. *The quantum equivariant product of two Schubert classes $\sigma_\lambda \star \sigma_\mu$ in $QH_T^*(Gr(k, n))$ can be computed by computing the equivariant product of the lifts of those classes to $H_T^*(Gr(k, 2n - 1))$ and then reducing in a suitable way. This reduction involves both rim-hook removal and a specialization of the torus weights modulo n .*

Prior to the work presented here, the strategies for computing EQLR coefficients were recursive or use computations in a related two-step flag variety. In [Mih06], Mihalcea gives a (non-positive) recursion for calculating the EQLR coefficients. Buch, Kresch, Purbhoo and Tamvakis [BKPT] prove an extension of the puzzle rule [KT03] to two-step flag manifolds, which in principle can be combined with results of [BKT03] to produce quantum Littlewood-Richardson coefficients. Buch has announced an extension of this result to the equivariant case [Buc13]. Our main theorem is a generalization of the results in [BCFF99], giving an equivariant analog of the rim hook rule. One distinct advantage of our method is that it is not recursive and can be easily implemented to efficiently compute EQLR coefficients using Sage's new puzzle calculation package!

To prove the theorem we show that the ring with product defined by this lift and reduction is associative and coincides with the product in $QH_T^*(Gr(k, n))$ when multiplying by the class corresponding to a single box. Theorem 3.1 of [Mih06] shows that these conditions suffice to yield a ring isomorphic to $QH_T^*(Gr(k, n))$. The proof of the equivariant quantum Pieri rule is straightforward; the real difficulty lies in proving the associativity statement. There are two key combinatorial ingredients in the proof. The

first tool is the abacus model for Young diagrams, which we use to understand the reduction modulo n on the torus weights. In addition, we develop a modification of factorial Schur functions, which we call *cyclic factorial Schur functions*, in order to relate the classical product in $H_T^*(Gr(k, 2n - 1))$ to the quantum product \star in $QH_T^*(Gr(k, n))$. We define cyclic factorial Schur functions in Section 5.

The authors expect there to be many interesting applications of this equivariant rim hook rule and cyclic factorial Schur functions in particular. For example, a stunning result of Peterson published by Lam and Shimozono [LS10] proves that quantum equivariant cohomology of any partial flag variety G/P is a quotient of the equivariant homology of the affine Grassmannian. Peterson’s isomorphism says that, up to localization, there is a map $H_*^T(Gr_G) \rightarrow QH_T^*(Gr(k, n))$. The reduction of torus weights modulo n in the main theorem of this paper also appears in the context of Lam and Shimozono’s work relating double quantum Schubert polynomials to k -double Schur polynomials [LS11]. It is the expectation of the authors that cyclic factorial Schur polynomials are the image of the k -double Schur polynomials, which are known to represent equivariant homology classes of the affine Grassmannian, under the Peterson isomorphism [LS13]. This connection suggests that the equivariant rim hook rule is a shadow of Peterson’s isomorphism and can shed further light on what has become known as the “quantum equals affine” phenomenon, and the authors intend to explore this in a future paper.

2 The Rim Hook Rule

In [BCFF99], Bertram, Ciocan-Fontanine, and Fulton established a delightful rule presenting quantum Littlewood-Richardson coefficients as signed sums of classical Littlewood-Richardson coefficients. The rim hook algorithm as phrased in [BCFF99] does not use the language of lifting Schubert classes, rather carrying out multiplication in the ring of Schur functions in variables x_1, \dots, x_k . We rephrase [BCFF99]’s main lemma below to draw the most natural parallel to our result. Choose the identity map to lift classes in $H^*(Gr(k, n))$ to $H^*(Gr(k, 2n - 1))$ and denote this lift of σ_λ by $\widehat{\sigma}_\lambda$.

Define $\varphi : H^*(Gr(k, 2n - 1)) \rightarrow QH^*(Gr(k, n))$ to be the \mathbb{Z} -module homomorphism generated by

$$\sigma_\gamma \mapsto \begin{cases} \prod_{i=1}^d ((-1)^{\varepsilon_i - k} q) \sigma_\nu & \text{if } \nu \in \mathcal{P}_{k,n}, \\ 0 & \text{if } \nu \notin \mathcal{P}_{k,n}, \end{cases} \quad (2.1)$$

where d is the number of n -rim hooks removed, ε_i is the height of the i^{th} rim-hook removed, and ν is the n -core of γ . Let $\mathcal{P}_{k,n}$ be the set of Young diagrams contained in the $k \times (n - k)$ rectangle.

Theorem 2.1 (Bertram, Ciocan-Fontanine, Fulton). *Consider $\lambda, \mu \in \mathcal{P}_{k,n}$, and write $\widehat{\sigma}_\lambda \cdot \widehat{\sigma}_\mu = \sum c_{\lambda,\mu}^\gamma \sigma_\gamma$ in $H^*(Gr(k, 2n - 1))$. Then,*

$$\sigma_\lambda \star \sigma_\mu = \sum_\gamma c_{\lambda,\mu}^\gamma \varphi(\sigma_\gamma) \in QH^*(Gr(k, n)). \quad (2.2)$$

Our theorem generalizes this rim hook rule of [BCFF99] to the context in which there is also an action of the torus $T_n = (\mathbb{C}^*)^n$. Equivariant cohomology $H_{T_n}^*(Gr(k, n))$ also has a Schubert basis indexed by Young diagrams, and the equivariant Littlewood-Richardson coefficients are homogeneous polynomials in $\Lambda = \mathbb{Z}[t_2 - t_1, \dots, t_n - t_{n-1}]$. There are combinatorial formulas for explicitly computing the expansions

$$\sigma_\lambda \cdot \sigma_\mu = \sum_\nu c_{\lambda,\mu}^\nu \sigma_\nu \quad (2.3)$$

in $H_{T_n}^*(Gr(k, n))$, where now each of the coefficients $c_{\lambda, \mu}^\gamma$ is a homogeneous polynomial in Λ . Perhaps the most famous of these is the *equivariant puzzle rule* of Knutson and Tao [KT03], illustrated in Figure 1. The three puzzles shown correspond to the following three terms, respectively, in the following product:

$$\sigma_{\square\square} \cdot \sigma_{\square\square} = \sigma_{\square\square} + (t_4 - t_3)\sigma_{\square\square} + (t_4 - t_3)(t_4 - t_2)\sigma_{\square\square}.$$

Note our conventions on the indices for the torus weights are the reverse of those of Knutson and Tao.

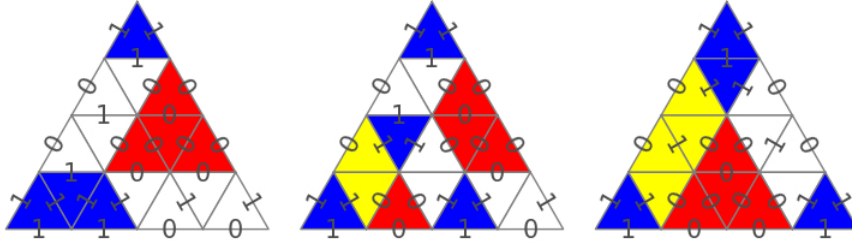

Fig. 1: Puzzles for computing products in $H_T^*(Gr(2, 4))$

Now extend the map $\varphi : H^*(Gr(k, 2n - 1)) \rightarrow QH^*(Gr(k, n))$ to a map $\varphi : H_{T_{2n-1}}^*(Gr(k, 2n - 1)) \rightarrow QH_{T_n}^*(Gr(k, n))$ by defining $t_i \mapsto t_{i \pmod n}$ to extend to the polynomial coefficients in the equivariant case. Here, we take the representatives of the congruence classes mod n to be $\{1, 2, \dots, n\}$. We will again denote the lift from $H_{T_n}^*(Gr(k, n)) \rightarrow H_{T_{2n-1}}^*(Gr(k, 2n - 1))$ by $\widehat{\sigma}_\lambda$, and it will again be the identity map.

Theorem 2.2. *Let $T_n = (\mathbb{C}^*)^n$ and $T_{2n-1} = (\mathbb{C}^*)^{2n-1}$. Consider $\lambda, \mu \in \mathcal{P}_{k,n}$, and the product expansion $\widehat{\sigma}_\lambda \cdot \widehat{\sigma}_\mu = \sum c_{\lambda, \mu}^\gamma \sigma_\gamma$ in $H_{T_{2n-1}}^*(Gr(k, 2n - 1))$. Then,*

$$\sigma_\lambda \star \sigma_\mu = \sum_{\gamma} \varphi \left(c_{\lambda, \mu}^\gamma \right) \varphi(\sigma_\gamma) \in QH_{T_n}^*(Gr(k, n)). \quad (2.4)$$

Example 2.3. We provide an example which illustrates how to use this theorem to compute quantum equivariant Littlewood-Richardson coefficients in $QH_T^*(Gr(2, 4))$. The computations in equivariant cohomology to provide these examples were done using the puzzles package in [S⁺13].

To compute $\sigma_{\square\square} \star \sigma_{\square\square} \in QH_T^*(Gr(2, 4))$, we first lift the classes to $H_T^*(Gr(2, 6))$ via the identity map. We then use Knutson and Tao's equivariant puzzle method to compute this product in $H_T^*(Gr(2, 6))$:

$$\begin{aligned} \widehat{\sigma}_{\square\square} \cdot \widehat{\sigma}_{\square\square} &= (t_4 - t_3)(t_4 - t_2)\sigma_{\square\square} + (t_4 - t_3)\sigma_{\square\square} + \sigma_{\square\square} \\ &\quad + (t_5 + t_4 - t_3 - t_2)\sigma_{\square\square} + \sigma_{\square\square} + \sigma_{\square\square}. \end{aligned} \quad (2.5)$$

The map φ on torus weights then says that $t_i \mapsto t_{i \pmod 4}$ so that $t_5 \mapsto t_1$ while the rest of the torus weights are unchanged. Now, φ acts as the identity on $\sigma_{\square\square}$, $\sigma_{\square\square}$, and $\sigma_{\square\square}$, since all three of these Young diagrams

already fit into a 2×2 box. On the other hand, $\sigma_{\square\square} \mapsto 0$, since this Young diagram neither fits into a 2×2 box nor contains any removable 4-rim hooks. Finally, our rim hook rule says that

$$\sigma_{\square\square} \mapsto (-1)^{2-2}q = q \quad \text{and} \quad \sigma_{\square\square\square} \mapsto (-1)^{1-2}q = -q. \quad (2.6)$$

Altogether, Theorem 2.2 says that in $QH_T^*(Gr(2, 4))$,

$$\sigma_{\square\square} \star \sigma_{\square\square} = (t_4 - t_3)(t_4 - t_2)\sigma_{\square\square} + (t_4 - t_3)\sigma_{\square\square} + \sigma_{\square\square} + 0 + q - q \quad (2.7)$$

$$= (t_4 - t_3)(t_4 - t_2)\sigma_{\square\square} + (t_4 - t_3)\sigma_{\square\square} + \sigma_{\square\square}. \quad (2.8)$$

3 Equivariant Littlewood-Richardson Coefficients

We prove Theorem 2.2 using the following result of [Mih06].

Theorem 3.1 (Mihalcea). *Let $\Lambda = \mathbb{Z}[t_1, \dots, t_n]$. Suppose that (A, \diamond) is a graded, commutative $\Lambda[q]$ -algebra with unit satisfying the following three properties:*

- (a) *A has an additive $\Lambda[q]$ -basis indexed by partitions in $\mathcal{P}_{k,n}$, denoted $\{A_\lambda\}$.*
- (b) *The equivariant quantum Pieri rule holds; i.e.*

$$A_{\square} \diamond A_\lambda = \sum_{\mu \rightarrow \lambda} A_\mu + c_{\lambda, \square}^\lambda A_\lambda + qA_{\lambda^-}, \quad (3.1)$$

where $\mu \rightarrow \lambda$ denotes a covering relation in $\mathcal{P}_{k,n}$, the polynomial $c_{\lambda, \square}^\lambda = \sum_{i \in U(\lambda)} t_i - \sum_{j=1}^k t_j$, and $U(\lambda)$ indexes the upward steps in the partition λ , recorded from southwest to northeast and λ^- is λ with an $(n-1)$ -rim hook removed; we set A_{λ^-} to 0 when λ^- doesn't exist.

- (c) *Multiplication by one box is associative; i.e.*

$$(A_{\square} \diamond A_\lambda) \diamond A_\mu = A_{\square} \diamond (A_\lambda \diamond A_\mu). \quad (3.2)$$

Then A is canonically isomorphic to $QH_T^*(Gr(k, n))$ as $\Lambda[q]$ -algebras.

We will be interested in the algebra A with additive basis $\{\sigma_\lambda \mid \lambda \in \mathcal{P}_{k,n}\}$, and the operation \circ given by the lift-reduction map φ defined in Section 2, so $\sigma_\lambda \circ \sigma_\mu = \varphi(\widehat{\sigma}_\lambda \cdot \widehat{\sigma}_\mu)$. To prove that (A, \circ) satisfies the hypotheses of Corollary 3.1, we have two primary tasks: to prove the Pieri and one box associativity rules.

3.1 The Equivariant Quantum Pieri Rule

We begin by reviewing Mihalcea's quantum equivariant Pieri rule, and we then show that our lift and reduction map agrees with Mihalcea's formula.

Theorem 3.2 (Equivariant quantum Pieri [Mih06]). *The following Pieri formula holds in $QH_{T_n}^*(Gr(k, n))$:*

$$\sigma_{\square} \star \sigma_\lambda = \sum_{\substack{\mu \rightarrow \lambda \\ \mu \in \mathcal{P}_{k,n}}} \sigma_\mu + c_{\lambda, \square}^\lambda \sigma_\lambda + q\sigma_{\lambda^-} \quad (3.3)$$

Proposition 3.3 (Equivariant rim hook Pieri). *For any Young diagram $\lambda \in \mathcal{P}_{k,n}$, we have:*

$$\varphi(\widehat{\sigma}_{\square} \cdot \widehat{\sigma}_{\lambda}) = \sigma_{\square} \star \sigma_{\lambda}. \quad (3.4)$$

Proof: If $\lambda_1 \neq n - k$ then λ^- doesn't exist and the result is immediate: we appeal to the non-quantum equivariant Pieri rule by setting $q = 0$ in Theorem 3.2 to say that

$$\varphi(\widehat{\sigma}_{\square} \cdot \widehat{\sigma}_{\lambda}) = \sum_{\substack{\mu \rightarrow \lambda \\ \mu \in \mathcal{P}_{k,n}}} \sigma_{\mu} + c_{\lambda, \square}^{\lambda} \sigma_{\lambda} = \sigma_{\square} \star \sigma_{\lambda}. \quad (3.5)$$

If $\lambda_1 = n - k$, we denote by $\bar{\lambda}$ the Young diagram $(n - k + 1) \geq \lambda_2 \geq \dots \geq \lambda_k$ in $\mathcal{P}_{k, 2n-1}$. Then

$$\varphi(\widehat{\sigma}_{\square} \cdot \widehat{\sigma}_{\lambda}) = \varphi \left(\sum_{\substack{\mu \rightarrow \lambda \\ \mu \in \mathcal{P}_{k, 2n-1}}} \sigma_{\mu} + c_{\lambda, \square}^{\lambda} \widehat{\sigma}_{\lambda} \right) \quad (3.6)$$

$$= \varphi \left(\sum_{\substack{\mu \rightarrow \lambda \\ \mu \in \mathcal{P}_{k,n}}} \widehat{\sigma}_{\mu} + c_{\lambda, \square}^{\lambda} \widehat{\sigma}_{\lambda} + \sigma_{\bar{\lambda}} \right) \quad (3.7)$$

$$= \sum_{\substack{\mu \rightarrow \lambda \\ \mu \in \mathcal{P}_{k,n}}} \sigma_{\mu} + c_{\lambda, \square}^{\lambda} \sigma_{\lambda} + q \sigma_{\lambda^-} \quad (3.8)$$

$$= \sigma_{\square} \star \sigma_{\lambda} \quad (3.9)$$

□

3.2 One Box Associativity

Proposition 3.4. *For any Young diagrams λ and μ in $\mathcal{P}_{k,n}$, we have*

$$(\sigma_{\square} \circ \sigma_{\lambda}) \circ \sigma_{\mu} = \sigma_{\square} \circ (\sigma_{\lambda} \circ \sigma_{\mu}). \quad (3.10)$$

The proof of Proposition 3.4 requires two fairly serious lemmas, which we state now and prove later in order not to interrupt the flow of the exposition.

Lemma 3.5. *Suppose that $\gamma \in \mathcal{P}_{k, 2n-1}$ reduces to the n -core $\nu \in \mathcal{P}_{k,n}$ by removing d rim hooks. Then*

$$\sum_{\substack{\delta \rightarrow \gamma \\ \delta \in \mathcal{P}_{k, 2n-1}}} \varphi(\sigma_{\delta}) = \sum_{\substack{\epsilon \rightarrow \nu \\ \epsilon \in \mathcal{P}_{k,n}}} q^d \sigma_{\epsilon} + q^{d+1} \sigma_{\nu^-} = q^d \sum_{\substack{\epsilon \rightarrow \nu \\ \epsilon \in \mathcal{P}_{k, 2n-1}}} \varphi(\sigma_{\epsilon}). \quad (3.11)$$

In particular, note that the n -core of ϵ equals ν^- if and only if $\nu_1 = n - k$ and $\nu_i > 0$ for all $1 \leq i \leq k$ and $\epsilon = \bar{\nu}$; otherwise, ϵ is an n -core.

Lemma 3.6. *In $QH_{T_n}^*(Gr(k, n))$, we have $\varphi(\sigma_{\bar{\lambda}} \cdot \widehat{\sigma}_{\mu}) = q \sigma_{\lambda^-} \circ \sigma_{\mu}$.*

The proof of Lemma 3.5 requires the use of abacus diagrams, which we discuss in Section 4. Proving Lemma 3.6 inspired the authors to develop a new polynomial model for equivariant quantum cohomology, which we call *cyclic factorial Schur functions*. Cyclic factorial Schur functions are discussed in Section 5.

Proof of Proposition 3.4: Write the coefficients obtained from our reduction as $\widetilde{c}_{\lambda,\mu}^{\nu,d}$.

$$\begin{aligned}
& (\sigma_{\square} \circ \sigma_{\lambda}) \circ \sigma_{\mu} \\
&= \left(\sum_{\substack{\delta \rightarrow \lambda \\ \delta \in \mathcal{P}_{kn}}} \sigma_{\delta} + q\sigma_{\lambda^-} + c_{\lambda,\square}^{\lambda} \sigma_{\lambda} \right) \circ \sigma_{\mu} && \text{by the equivariant rim hook Pieri rule} \\
&= \sum_{\substack{\delta \rightarrow \lambda \\ \delta \in \mathcal{P}_{kn}}} \sigma_{\delta} \circ \sigma_{\mu} + \varphi(\sigma_{\bar{\lambda}} \cdot \sigma_{\mu}) + c_{\lambda,\square}^{\lambda} \sigma_{\lambda} \circ \sigma_{\mu} && \text{by Lemma 3.6} \\
&= \sum_{\substack{\delta \rightarrow \lambda \\ \delta \in \mathcal{P}_{kn}}} \sigma_{\delta} \circ \sigma_{\mu} + \varphi(\sigma_{\bar{\lambda}} \cdot \widehat{\sigma}_{\mu}) + c_{\lambda,\square}^{\lambda} \sigma_{\lambda} \circ \sigma_{\mu} && \text{since } \mu \in \mathcal{P}_{k,n}, \text{ then we may replace } \sigma_{\mu} \text{ by } \widehat{\sigma}_{\mu} \\
&= \varphi \left(\left(\sum_{\substack{\delta \rightarrow \lambda \\ \delta \in \mathcal{P}_{k,2n-1}}} \sigma_{\delta} + c_{\lambda,\square}^{\lambda} \widehat{\sigma}_{\lambda} \right) \cdot \widehat{\sigma}_{\mu} \right) \\
&= \varphi((\widehat{\sigma}_{\square} \cdot \widehat{\sigma}_{\lambda}) \cdot \widehat{\sigma}_{\mu}). \\
&= \varphi(\widehat{\sigma}_{\square} \cdot (\widehat{\sigma}_{\lambda} \cdot \widehat{\sigma}_{\mu})) && \text{since } H_T^*(Gr(k, 2n-1)) \text{ is associative} \\
&= \varphi \left(\sum_{\gamma \in \mathcal{P}_{k,2n-1}} c_{\lambda,\mu}^{\gamma} (\widehat{\sigma}_{\square} \cdot \sigma_{\gamma}) \right) \\
&= \sum_{\nu \in \mathcal{P}_{kn,d}} \widetilde{c}_{\lambda,\mu}^{\nu,d} q^d \varphi \left(\sum_{\substack{\epsilon \rightarrow \nu \\ \epsilon \in \mathcal{P}_{k,2n-1}}} \sigma_{\epsilon} \right) + \sum_{\nu \in \mathcal{P}_{kn,d}} \widetilde{c}_{\lambda,\mu}^{\nu,d} q^d c_{\nu,\square}^{\nu} \sigma_{\nu} && \text{by Lemmas 3.5 and 4.2} \\
&= \sum_{\nu \in \mathcal{P}_{kn,d}} \widetilde{c}_{\lambda,\mu}^{\nu,d} q^d \varphi(\widehat{\sigma}_{\square} \cdot \widehat{\sigma}_{\nu}) && \text{by the equivariant Pieri rule} \\
&= \sigma_{\square} \circ (\sigma_{\lambda} \circ \sigma_{\mu}).
\end{aligned}$$

□

4 Abacus Diagrams

This section is devoted to the proof of the first key lemma involved in the proof of one box associativity, which is Lemma 3.5. The main tool for proving this lemma is the abacus model of a Young diagram; see [JK81] for more details. An *abacus* has n columns called *runners* labeled with all of the integers

written in order, from left to right and then top to bottom. On the runners, an infinite number of *beads* are placed on the integers, satisfying the condition that there exists an integer N with no beads after N and a bead at every integer before $-N$. We shall require that the last k beads, called *active* beads, are the only beaded integers with a *gap* (a non-beaded integer) preceding them. Our convention places 0 on the leftmost runner.

To obtain the Young diagram λ corresponding to an abacus \mathcal{A} , start with the last bead, which has highest integer value. The number of gaps before the i^{th} to last bead is λ_i . We recover $\lambda = (\lambda_1, \dots, \lambda_k)$ by looking at the k active beads. The left half of Figure 2 shows an abacus for $\lambda = (2, 1)$ with $n = 3$ runners and two active beads. To create an abacus \mathcal{A} from a partition λ , place a bead on every number in $\mathbb{Z}_{\leq 0}$, and then for i from 1 to k , place a bead on location $\lambda_{k-i+1} + i - 1$. Note that there are many other abaci with corresponding partition λ , for example any abacus in which we translate all beads on the abacus vertically by the same amount.

An abacus is called *flush* if each bead has another bead directly above it. For example, the abacus given on the left in figure 2 is not flush, but the abacus given on the right in figure 2 is flush.

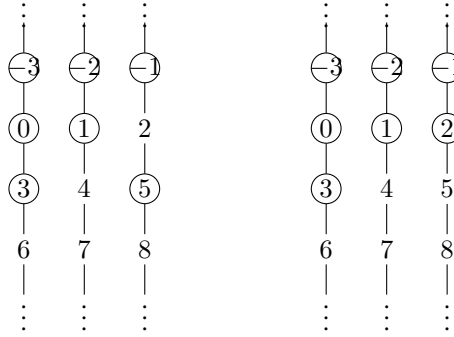

Fig. 2: An abacus for $\lambda = (2, 1)$ with 3 runners (left) and an abacus for $\lambda = (0)$ with 3 runners (right).

Theorem 4.1 (see [JK81]). λ is an n -core if and only if every (equivalently any) abacus corresponding to λ is flush. Additionally, removing a single n -rim hook from λ corresponds to moving one bead up one row on an abacus runner.

Lemma 4.2. Let $c_{\gamma, \square}^{\gamma}$ be a coefficient in $H_{T_{2n-1}}^*(Gr(k, 2n-1))$ and $c_{\nu, \square}^{\nu}$ be a coefficient in $H_{T_n}^*(Gr(k, n))$. If γ reduces to ν by removing n -rim hooks, then $\varphi(c_{\gamma, \square}^{\gamma}) = c_{\nu, \square}^{\nu} = c_{\nu, \square}^{\nu, 0} \in QH_{T_n}^*(Gr(k, n))$.

Proof: The equivariant Littlewood-Richardson coefficient $c_{\gamma, \square}^{\gamma}$ can be written as a sum over locations of active beads on an abacus independently of the number of runners:

$$c_{\gamma, \square}^{\gamma} = \sum_{j=1}^k (t_{j-1+g(j)} - t_j) = \left(\sum_{j=1}^k t_{j-1+g(j)} \right) - (t_1 + \dots + t_k), \quad (4.1)$$

where $g(j)$ is the number of gaps before the j^{th} bead. Moving a bead up or down on a particular runner changes the index $j - 1 + g(j)$ by n , so indices are constant modulo n . \square

Lemma 4.3. *When $\lambda = (\lambda_1, \dots, \lambda_k)$ and $\square(\lambda) = (\lambda_1, \dots, \lambda_{i-1}, \lambda_i + 1, \lambda_{i+1}, \dots, \lambda_k)$ are both valid Young diagrams, an abacus for $\square(\lambda)$ can be obtained from an abacus for λ by moving a bead on the abacus for λ one runner to the right, or if it is already on the rightmost runner moving it to the leftmost runner down one row.*

Proof: The number of boxes in row i of a Young diagram λ corresponds to the number of gaps before the i^{th} from the last active bead in an abacus for λ . We can add a box in the i^{th} row if and only if there are at least $\lambda_i + 1$ boxes in the $(i + 1)^{\text{th}}$ row of λ . This is the case if and only if there is a gap between the i^{th} and $(i + 1)^{\text{th}}$ active bead in the abacus for λ . \square

Lemma 4.4. *If a Young diagram γ of at most k parts has n -core in $\mathcal{P}_{k,n}$ then any abacus for γ has each of the k active beads on distinct runners.*

Proof: First, assume that γ is itself a Young diagram in $\mathcal{P}_{k,n}$ (and hence an n -core). Since each part of γ is of size at most $n - k$, we have at most $n - k$ gaps between the first and last active bead. As there are n runners and k active beads, that means that the first active bead is located at most $n - 1$ runners away from the last active bead; *i.e.* each active bead is on a separate runner.

Taking an n -core does not change the runners on which the active beads of an abacus appear. Therefore, if γ has n -core in $\mathcal{P}_{k,n}$, the active beads on γ 's abacus must also be on distinct runners. \square

Proof of Lemma 3.5: We shall show the first equality in Equation (3.11) by showing that each term in the second expression appears in the first and then that each term appears at most once.

Recall that Lemma 3.5 assumes that $\gamma \in \mathcal{P}_{k,2n-1}$ rim hook reduces to the n -core $\nu \in \mathcal{P}_{k,n}$ by removing d rim hooks. Let \mathcal{A}_γ be the abacus for γ . We can obtain an abacus \mathcal{A}_ν for ν by moving each active bead on \mathcal{A}_γ up as far as possible. Since each active bead of \mathcal{A}_γ is on a different runner by Lemma 4.4, we may move the first active bead up as far as possible, then the second active bead up, and proceed in order to the last active bead. We need never move any bead again and we have obtained an abacus \mathcal{A}_ν for ν . From \mathcal{A}_ν we can obtain \mathcal{A}_ϵ for any $\epsilon \rightarrow \nu$ by moving an active bead one runner to the right on \mathcal{A}_ν , according to Lemma 4.3. This will be an n -core unless the bead moves over a gap, in which case the bead must be the last active bead in \mathcal{A}_ν by Lemma 4.4. In this case, taking the n -core of ϵ we must get ν^- . In either case, for each ϵ we can reverse the process of obtaining \mathcal{A}_ν from \mathcal{A}_γ to obtain an abacus for a δ with n -core ϵ .

Now we shall show that each term in the second expression appears at most once in the first expression. We shall assume for sake of contradiction that two partitions $\delta_1 \rightarrow \gamma$ and $\delta_2 \rightarrow \gamma$ and δ_1 and δ_2 rim hook reduce to the same $\epsilon \in \mathcal{P}_{k,n}$. Consider an abacus \mathcal{A}_ν such that all k active beads appear on the row containing 0 with the last active bead on location $n - 1$, and fix \mathcal{A}_γ an abacus for γ that reduces to \mathcal{A}_ν . Abaci corresponding to δ_1 and δ_2 , say \mathcal{A}_{δ_1} and \mathcal{A}_{δ_2} , can be obtained by moving a bead from \mathcal{A}_γ one runner to the right.

If neither bead moved was on the rightmost runner in \mathcal{A}_γ , then when \mathcal{A}_{δ_1} and \mathcal{A}_{δ_2} are made flush to obtain an abacus for ϵ , we must get the same abacus in both cases. Since \mathcal{A}_{δ_1} and \mathcal{A}_{δ_2} differed only in two beads in order not to violate Lemma 4.4, we must have $\mathcal{A}_{\delta_1} = \mathcal{A}_{\delta_2}$ and hence $\delta_1 = \delta_2$, a contradiction.

Now suppose that to create \mathcal{A}_{δ_1} we move the bead on the rightmost runner in \mathcal{A}_γ to the leftmost runner. If there is no inactive bead on location 0 in \mathcal{A}_γ then again all of the active beads will be in row 0 when \mathcal{A}_{δ_1} and \mathcal{A}_{δ_2} are made flush, but these two flush abaci will have unequal k^{th} parts and cannot be the same ϵ . If there is a non-active bead at 0 in \mathcal{A}_γ , then the bead moved to the leftmost runner to form \mathcal{A}_{δ_1} will

still correspond to the largest part of ϵ when \mathcal{A}_{δ_1} is made flush. Since $\mathcal{A}_{\delta_1} \neq \mathcal{A}_{\delta_2}$, then via construction their n -cores do not have equal first parts, which is a contradiction.

The second equality follows from the proof of Proposition 3.3. \square

5 Cyclic Factorial Schur Functions

Mihalcea proved in [Mih08] that

$$R = \mathbb{Z}[q, e_1(x|t), \dots, e_k(x|t)] / \langle h_{n-k+1}(x|t), \dots, h_n(x|t) + (-1)^k q \rangle \cong QH_{T_n}^*(Gr(k, n)). \quad (5.1)$$

Here $e_i(x|t)$ are factorial elementary and $h_i(x|t)$ are factorial homogenous complete symmetric polynomials, in x_1, \dots, x_k and t_1, \dots, t_n . Let J denote the ‘‘quantum ideal’’ $\langle h_{n-k+1}(x|t), \dots, h_n(x|t) + (-1)^k q \rangle$. Recall the definition of factorial Schur functions:

Definition 5.1. The *factorial Schur polynomial* $s_\lambda(x|t)$ corresponding to $\sigma_\lambda \in H_{T_n}^*(Gr(k, n))$ is

$$s_\lambda(x|t) = \sum_T \prod_{\alpha \in T} (x_{T(\alpha_{ij})} - t_{T(\alpha_{ij})+j-i}), \quad (5.2)$$

where the sum is over semistandard fillings of the tableaux T by 1 through k , and the product is over boxes α_{ij} in T . Here, α_{ij} denotes the box in the i^{th} row and j^{th} column, and $T(\alpha_{ij})$ gives the entry in box α_{ij} in T .

Definition 5.2. We define *cyclic factorial Schur polynomials* to be the polynomials obtained by reducing factorial Schur polynomials in $2n$ torus variables t_i to polynomials in n torus variables via $t_i \mapsto t_{i \pmod n}$.

Notice that this reduction is the identity on the ring $R \cong QH_{T_n}^*(Gr(k, n))$, as the largest index possible is $k + n - k - 1 = n - 1$. Because of the isomorphism between the ring of factorial Schur functions and $QH_{T_n}^*(Gr(k, n))$, it suffices to prove the following reformulation of Lemma 3.6:

Proposition 5.3. For $\mu, \lambda \in \mathcal{P}_{k,n}$ with $\lambda_1 = n - k$,

$$\varphi(s_{\bar{\lambda}}(x|t)s_\mu(x|t)) = qs_{\lambda^-}(x|t)s_\mu(x|t) \pmod J. \quad (5.3)$$

We will need the following lemma on quantum invariance:

Lemma 5.4 (Quantum invariance under shift). *Let $\tau^s t$ denote the shifted torus weights given by $\tau^s t_i = t_{s+i}$. In the ring R , we have $h_m(x|\tau^{1-j}t) = 0 \pmod J$ for all j and all m such that $n - k < m < n$, and $h_n(x|\tau^{1-j}t) = q \pmod J$ for all j .*

Proof: We use induction on s . Since $h_j(x|\tau^{-s}t) = h_j(x|\tau^{-s+1}t) + (t_{j+k-s} - t_{-s+1})h_{j-1}(x|\tau^{-s+1}t)$, by page 2295 in [Mih08], we can simply plug in $j = n - k + \ell$ to write

$$h_{n-k+\ell}(x|\tau^{-s}t) = h_{n-k+\ell}(x|\tau^{-s+1}t) + (t_{n-k+\ell+k-s} - t_{-s+1})h_{n-k+\ell-1}(x|\tau^{-s+1}t). \quad (5.4)$$

Notice that for $\ell = 1$, this simplifies to

$$h_{n-k+1}(x|\tau^{-s}t) = h_{n-k+1}(x|\tau^{-s+1}t) + (t_{n-s+1} - t_{-s+1})h_{n-k}(x|\tau^{-s+1}t), \quad (5.5)$$

and under our reduction of indices modulo n , the difference $t_{n-s+1} - t_{-s+1} = 0$. Thus

$$h_{n-k+1}(x|\tau^{-s}t) = h_{n-k+1}(x|\tau^{-s+1}t), \quad (5.6)$$

and by induction on s one sees that both are equal to zero mod J as $h_{n-k+1}(x|t) \in J$. For $1 < \ell < k$,

$$h_{n-k+\ell}(x|\tau^{-s}t) = h_{n-k+\ell}(x|\tau^{-s+1}t) + (t_{n-k+\ell+k-s} - t_{-s+1})h_{n-k+\ell-1}(x|\tau^{-s+1}t). \quad (5.7)$$

However, $h_{n-k+\ell-1}(x|\tau^{-s+1}t)$ reduces to zero mod J as one can again see by induction on s . For $j = n$, we have $h_n(x|\tau^{-s}t) = h_n(x|\tau^{-s+1}t) + (t_{n+k-s} - t_{-s+1})h_{n-1}(x|\tau^{-s+1}t)$, but by our previous computations $h_{n-1}(x|\tau^{-s+1}t)$ is zero modulo J and so $h_n(x|\tau^{-s}t) = h_n(x|\tau^{-s+1}t)$. \square

Proof of Proposition 5.3: To establish Proposition 5.3, we use the Jacobi-Trudi formula to express the products of the two Schur functions $s_{\bar{\lambda}}(x|t)s_{\mu}(x|t)$ and $s_{\lambda^-}(x|t)s_{\mu}(x|t)$. First write

$$s_{\bar{\lambda}}(x|t)s_{\mu}(x|t) = \det \left(\sum_{\ell=1}^k h_{\bar{\lambda}_i+i-\ell}(x|\tau^{1-\ell}t) h_{\mu_{\ell}+j-\ell}(x|\tau^{1-j}t) \right)_{1 \leq i, j \leq k}. \quad (5.8)$$

Using the quantum invariance lemma above, notice that $h_{n-k+1+i-\ell} = 0$ when the index ranges between $n-k+1$, and $n-1$ when we reduce mod the quantum ideal J regardless of shift τ . Since $\bar{\lambda}_1 = n-k+1$, the only entry in the first row of the matrix in (5.8) that is non-zero mod J is the last one. Expanding the determinant along the first row of the matrix then gives

$$\begin{aligned} (-1)^k h_n(x|\tau^{1-k}t) \det \left(\sum_{\ell=1}^{k-1} h_{\lambda_{i+1}-1+\ell-i+1}(x|\tau^{1-\ell}t) h_{\mu_{\ell}-\ell+j}(x|\tau^{1-j}t) \right) = \\ (-1)^k q \det \left(\sum_{\ell=1}^{k-1} h_{\lambda_{i+1}-1+\ell-i+1}(x|\tau^{1-\ell}t) h_{\mu_{\ell}-\ell+j}(x|\tau^{1-j}t) \right) \pmod{J}. \end{aligned} \quad (5.9)$$

When we look at $s_{\lambda^-}(x|t)s_{\mu}(x|t)$ we get

$$s_{\lambda^-}(x|t)s_{\mu}(x|t) = \det \left(\sum_{\ell=1}^k h_{\lambda_{i+1}-1+\ell-i+1}(x|\tau^{1-\ell}t) h_{\mu_{\ell}-\ell+j}(x|\tau^{1-j}t) \right). \quad (5.10)$$

Since $\lambda_{k+1} = 0$, the last row consists of $k-1$ zeroes followed by a one. Expanding along the last row of the matrix, we get

$$s_{\lambda^-}(x|t)s_{\mu}(x|t) = (-1)^k \det \left(\sum_{\ell=1}^{k-1} h_{\lambda_{i+1}-1+\ell-i+1}(x|\tau^{1-\ell}t) h_{\mu_{\ell}-\ell+j}(x|\tau^{1-j}t) \right), \quad (5.11)$$

which differs from the reduction applied to $s_{\bar{\lambda}}(x|t)s_{\mu}(x|t)$ by exactly the factor $(-1)^k q$, as desired. Thus $\varphi(s_{\bar{\lambda}}(x|t)s_{\mu}(x|t)) = q s_{\lambda^-}(x|t)s_{\mu}(x|t) \pmod{J}$. \square

Acknowledgements

Part of the work for this paper was completed during the semester program on “Multiple Dirichlet Series, Combinatorial Representation Theory, and Multiple Dirichlet Series” at the Institute for Computational and Experimental Research in Mathematics in the spring of 2013. The authors are very grateful for the financial support and excellent working conditions at ICERM. The last author also thanks Cornell and the Mathematical Sciences Research Institute (MSRI). In addition, several important aspects of the work were tested and implemented using the computer package Sage. Thanks to those who wrote the Knutson-Tao puzzles package during Sage Days 45, most notably Franco Saliola, Anne Schilling, Ed Richmond, and Avinash Dalal, in discussions with Allen Knutson.

References

- [BCFF99] Aaron Bertram, Ionuț Ciocan-Fontanine, and William Fulton, *Quantum multiplication of Schur polynomials*, J. Algebra **219** (1999), no. 2, 728–746.
- [BKPT] Anders Skovsted Buch, Andrew Kresch, Kevin Purbhoo, and Harry Tamvakis, *The two step puzzle conjecture*.
- [BKT03] Anders Skovsted Buch, Andrew Kresch, and Harry Tamvakis, *Gromov-Witten invariants on Grassmannians*, J. Amer. Math. Soc. **16** (2003), no. 4, 901–915 (electronic).
- [Buc13] Anders Skovsted Buch, *Mutations of puzzles and equivariant cohomology of two-step flag varieties*, preprint in preparation, 2013.
- [FP97] W. Fulton and R. Pandharipande, *Notes on stable maps and quantum cohomology*, Algebraic geometry—Santa Cruz 1995, Proc. Sympos. Pure Math., vol. 62, Amer. Math. Soc., Providence, RI, 1997, pp. 45–96.
- [Giv96] Alexander B. Givental, *Equivariant Gromov-Witten invariants*, Internat. Math. Res. Notices (1996), no. 13, 613–663.
- [GK95] Alexander Givental and Bumsig Kim, *Quantum cohomology of flag manifolds and Toda lattices*, Comm. Math. Phys. **168** (1995), no. 3, 609–641.
- [JK81] Gordon James and Adalbert Kerber, *The representation theory of the symmetric group*, Encyclopedia of Mathematics and its Applications, vol. 16, Addison-Wesley Publishing Co., Reading, Mass., 1981, With a foreword by P. M. Cohn, With an introduction by Gilbert de B. Robinson.
- [KT03] Allen Knutson and Terence Tao, *Puzzles and (equivariant) cohomology of Grassmannians*, Duke Math. J. **119** (2003), no. 2, 221–260.
- [LS10] Thomas Lam and Mark Shimozono, *Quantum cohomology of G/P and homology of affine Grassmannian*, Acta Math. **204** (2010), no. 1, 49–90.
- [LS11] Thomas Lam and Mark Shimozono, *From double quantum Schubert polynomials to k -double Schur functions via the Toda lattice*, 2011.

- [LS13] Thomas Lam and Mark Shimozono, *k*-double Schur functions and equivariant (co)homology of the affine Grassmannian, *Math. Ann.* **356** (2013), no. 4, 1379–1404. MR 3072805
- [Mih06] Leonardo Mihalcea, *Equivariant quantum Schubert calculus*, *Adv. Math.* **203** (2006), no. 1, 1–33.
- [Mih08] Leonardo Constantin Mihalcea, *Giambelli formulae for the equivariant quantum cohomology of the Grassmannian*, *Trans. Amer. Math. Soc.* **360** (2008), no. 5, 2285–2301.
- [MS99] Alexander I. Molev and Bruce E. Sagan, *A Littlewood-Richardson rule for factorial Schur functions*, *Trans. Amer. Math. Soc.* **351** (1999), no. 11, 4429–4443.
- [S⁺13] W. A. Stein et al., *Sage Mathematics Software (Version 5.10)*, The Sage Development Team, 2013, <http://www.sagemath.org>.

