

## Design of a Measurement and Control System for Delinting Machine

Liming Zhou, Yanwei Yuan, Junning Zhang, Xin Dong

► **To cite this version:**

Liming Zhou, Yanwei Yuan, Junning Zhang, Xin Dong. Design of a Measurement and Control System for Delinting Machine. Daoliang Li; Yingyi Chen. 8th International Conference on Computer and Computing Technologies in Agriculture (CCTA), Sep 2014, Beijing, China. IFIP Advances in Information and Communication Technology, AICT-452, pp.646-652, 2015, Computer and Computing Technologies in Agriculture VIII. <10.1007/978-3-319-19620-6\_72>. <hal-01420283>

**HAL Id: hal-01420283**

**<https://hal.inria.fr/hal-01420283>**

Submitted on 20 Dec 2016

**HAL** is a multi-disciplinary open access archive for the deposit and dissemination of scientific research documents, whether they are published or not. The documents may come from teaching and research institutions in France or abroad, or from public or private research centers.

L'archive ouverte pluridisciplinaire **HAL**, est destinée au dépôt et à la diffusion de documents scientifiques de niveau recherche, publiés ou non, émanant des établissements d'enseignement et de recherche français ou étrangers, des laboratoires publics ou privés.



# Design of a Measurement and Control System for Delinting Machine

Liming Zhou<sup>1,a</sup>, Yanwei Yuan<sup>1,b</sup>, Junning Zhang<sup>1,c</sup>, Xin Dong<sup>1,d</sup>

<sup>1</sup> Chinese Academy of Agricultural Mechanization Sciences, Beijing 100083, China  
<sup>a</sup>haibo1129@163.com, <sup>b</sup>yyw215@163.com, <sup>c</sup>zjn990210@163.com, <sup>d</sup>191942384@qq.com

**Abstract.** To improve the working efficiency of cottonseed delinting machine, an automated measurement and control system for the machine is designed. The system hardware is comprised of three torque sensor, master controller, data acquisition and regulation module, displacement transducer, linear actuator and variable frequency device. The operating parameters such as the rotation torque and speed of every delinting cylinder and outlet opening are obtained on line by the apparatus and then sent to the master controller. With the help of LabWindow/CVI, the master controller program is developed to get and deal with the information. Since the feed rate and discharge rate directly affect the working load of the cylinders, the speed of feeding motor and outlet opening can be manually regulated by means of the program to facilitate the working load test experiment. In order to achieve the optimization load allocation of the delinting cylinder, the optimal decision is made on the basis of the third cylinder's working load to regulate the outlet opening. The experiment results show that the outlet opening regulation accuracy reaches  $\pm 1\text{mm}$ . This system is also easy to use and provide a good graphical user interface and has higher accuracy, higher efficiency for the real-time control.

**Keywords:** delinting machine, measurement and control system, LabWindows/CVI

## 1 Introduction

Cottonseed is not only a major by-product of cotton processing, but also an important resource that we need to improve the utilization. At present, there are two important delinting methods: chemical acid delinting [1] and mechanical delinting [2-3]. The foamed sulfuric acid is often used in the acid delinting. Due to churning action, cotton fuzz is uniformly subjected to the acid reaction. After a moment, the acid treats seeds and the slurry is washed with the water. This method is a simple technology, but there are some disadvantages such as high production costs, dangerous operation, and environment pollution. Mechanical delinting relies on physical friction to remove the fuzz forcibly. Since no acid is used in the process, there are many advantages for this method. For example, the environment pollution is prevented and the production cost is reduced and the fuzz can be recycled. Steel brush organization is the main form of structural mechanical delinter. With the help of centrifugal force, the rotating cylinder with opposite spinning rotary brush can remove fuzz from cottonseed easily. A number of rotating cylinders are often used at the same time to improve the efficiency of delinting machine. Due to the abrasive action of the brush, care must be taken to prevent overheating the seed and damaging the seed coat. During the mechanical

delinting process, there is an obvious relationship between working load of cylinder and delinting quality. So far, many efforts have been made to improve the quality of cotton seed delinting. Wang [4] used the automatic control technology and information processing technology to the parameters such as concentration, temperature and so on during the acid delinting process. Zuo [5] developed an automatic feed rate control system for the mechanical delinter by comparing the desire value with real value of feeding motor current. Chen [6] designed a frequency automatic setting system of seed feeding mechanism to keep the feed rate stable. These improvements are based on the simple open loop control to regulate the feed rate and do not take into account the working load of cylinder. So, it is difficult to improve the delinting quality effectively.

Therefore, in order to improve the delinting efficiency and reduce the damage rate of cottonseed, the measurement and control system for third level delinting machine is developed based on virtual instrument in this paper. According to the working load of the third rotating cylinder, the system can adjust the outlet opening automatically so as to keep the working load stable. When the outlet is in good condition, the rotating cylinder will work at its best. On this condition, the delinting efficiency is high, and the damage rate of cottonseed is low. Meanwhile, for the convenience of delinting test experiments, the system also integrates the manual adjustment of feeding motor speed and outlet opening function.

## 2 Materials and Methods

### 2.1 Cottonseed Delinting Machine

The delinting machine studied in this paper includes main frame, feed hopper, three rotating cylinder and fuzz recycling unit. The cylinders are comprised of screen mesh and steel brush. The simple structure of delinter machine is shown in Fig.1. To ensure the cottonseed pass through the delinting machine smoothly, the rotation direction of first cylinder is opposite to that of the second cylinder, and is the same to that of the third cylinder. These cylinders are driven by an AC motor, which power is 45kw. The power of feeding motor is 0.75kw.

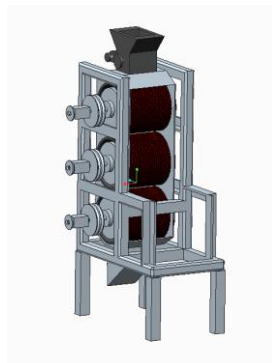

Fig.1 Structure of cottonseed delinting machine

## 2.2 Hardware of Measurement Control System

The main function of the control system is to acquire the rotating cylinders torque and speed information to get the working status of the cylinders and carry out the torque control automatically. The system also can regulate the speed of feeding motor and outlet opening easily by means of manual mode to facilitate the experiment. The system is comprised of three torque sensor, master controller, data acquisition and regulation module, displacement transducer, linear actuator and variable frequency device. Its structure is shown in figure 2.

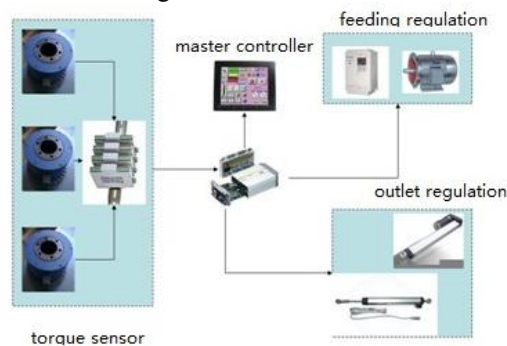

Fig.2 Schematic of the measurement and control system for delinting machine

### 2.2.1 Torque Sensor

In order to obtain working load of the cylinder accurately, the belt pulley torque sensor is selected in this paper. The sensor can provide extremely accurate torque measurement and speed measurement over a broad range. Unlike the tradition torque sensor, the pulley torque sensor can measure belt or chain torque on pulley system directly [7]. It is applicable to a mechanical rig without set screw and with the rotary cylinder driven by a chain/belt case. The selected torque sensors are mounted directly on the outside of pulley, without having to disconnect the drive shaft. According to the cylinders motor drive power, the working torque of every cylinder is estimated, then the measurement range of 0-300 Nm can be determined. The output of torque sensor is a digital pulse signal to avoid the electromagnetic disturb.

### 2.2.2 Data Acquisition and Regulation Module

Data acquisition and regulation module is mainly used to obtain signals of torque sensors, displacement transducer and feeding motor speed sensor and carry out the outlet opening regulation. STC12C5A60S2 microcontroller and the corresponding peripheral module are combined with the data acquisition circuit. Acquisition circuit includes a microcontroller, input pulse optocoupler isolation, 82C54 pulse counter,

analog to digital conversion circuit, RS232 communication interface. Input pulse optocoupler isolation circuit is mainly used as the amplitude converter of torque sensors signals. It can convert rotation torque and speed signals and feeding motor speed signal into TTL-level signals. Then, the signals are sent to the programmable interval timer 82C54 to count. Analog to digital conversion circuit is mainly used to convert the displacement sensor signal to digital codes. Finally, the information on rotation torque and speed of cylinder and outlet opening is sent to the master controller by STC12C5A60S2 via RS232.

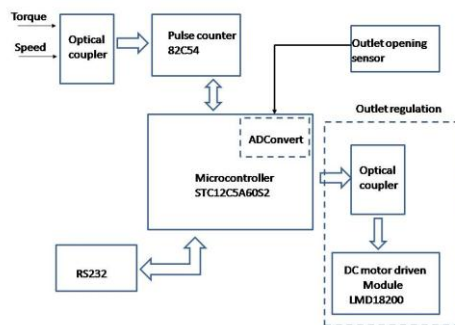

Fig.3 Schedule model of the data acquisition and regulation module

Linear actuator is used to regulate the outlet opening of delinting machine. For the high accuracy of outlet opening regulation, the displacement transducer is arranged to provide the out electrical signal proportional to the mechanical movement of linear actuator. An H-Bridge LMD18200 is selected to drive the linear actuator. LMD18200 has a perfect logic control and protection circuit [8]. It can provide good support for PWM control. The PWM and direction signal of LMD18200 are provided by the microcontroller and isolated by optocoupler.

### 2.3 Software Design of The System

Virtual Instrument tool LabWindows/CVI is chosen as the software design platform. LabWindows/CVI is an ANSI C programming environment for test measurement developed by Nation Instruments Corporation. It provides powerful function libraries and a comprehensive set of software tools for data acquisition, analysis and presentation [9-10]. In the program development process, we can compiled C object modules, dynamic library link, C libraries, and instrument drivers in conjunction with ANSI C source files. The system developed in this paper has some key functions as follows: auto-acquiring parameters of delinting machine such as rotation torque and speed of cylinder, automatic torque control of third cylinder, adjusting feed rate and outlet opening by manual. The software can also display, save and print these signals in graphic and numeric form. The program interface is shown in Fig.4.

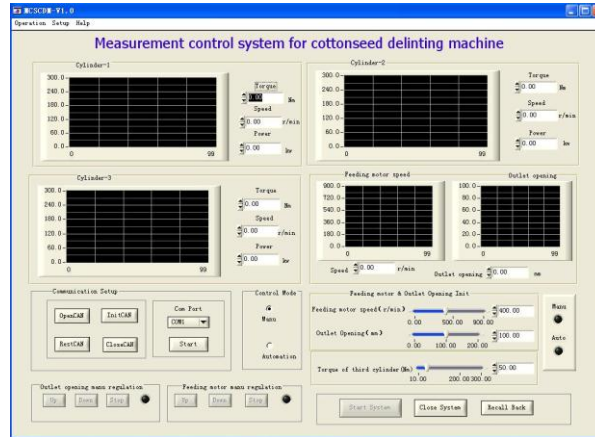

Fig.4 Interface of the control system

As noted previously, the microcontroller sends the information to master controller. The information includes rotation torque and speed signals of cylinders, feeding motor speed and outlet opening. When the PC program receives these data, they are saved and displayed in the interface. The multithread technology is applied to satisfy the real time and accuracy requirement.

According to the measured torque of the third cylinder and the set value, we can use incremental PID control algorithm to regulate the outlet opening in order to keep the torque stable. In addition, the feeding motor speed is also adjusted manually by the program through the transmission frequency commands from the PC to the variable frequency device via RS485. The outlet opening is regulated manually by the program through the transmission commands to the microcontroller via RS232.

### 3 Results and Discussion

#### 3.1 Outlet opening regulation accuracy

To qualify the outlet opening regulation accuracy, the experiment about outlet opening control was practiced. First, we set some desire value of outlet opening at the program interface. Then, the linear actuator moved until the outlet opening reached the desire value. At the same time, the actual value could be obtained by the displacement sensor. The comparison results of desire value and actual value are shown in table 1.

Table 1. Comparison results of desire value and actual value of outlet opening

| Desire value<br>,mm | Forward<br>value ,mm | actual | Absolute<br>error, mm | reverse<br>value , mm | actual | Absolute<br>error, mm |
|---------------------|----------------------|--------|-----------------------|-----------------------|--------|-----------------------|
| 30                  | 29.4                 |        | -0.6                  | 30.7                  |        | 0.7                   |
| 63                  | 62.5                 |        | -0.5                  | 64.0                  |        | 1.0                   |
| 96                  | 95.2                 |        | -0.8                  | 96.7                  |        | 0.7                   |
| 129                 | 128.3                |        | -0.7                  | 129.6                 |        | 0.6                   |
| 162                 | 161.4                |        | -0.6                  | 162.9                 |        | 0.9                   |

From the table1, it is clear that the regulation of outlet opening is very precise, and the maximum error of it is 1mm.

### 3.2 Relationship between Outlet Opening and Torque of the Third Cylinder

In order to realize the torque control, we should study the relationship between outlet opening and torque of the third cylinder firstly. The result is shown in Fig. 5. From the figure, we know that the relationship between the torque and outlet opening is very strong. With the outlet opening becoming larger, the torque of third cylinder gradually decreases. Therefore, the torque can be adjusted by changing the outlet opening.

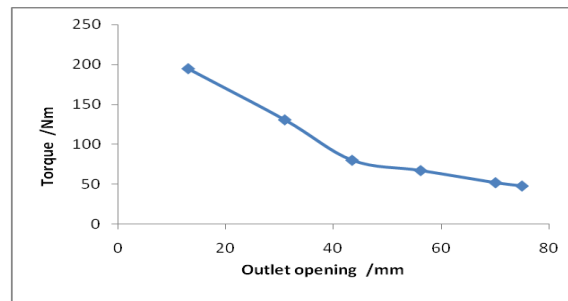

Fig.5 Relationship between outlet opening and torque of third cylinder

### 3.3 Torque Automatic Control

The torque of the third cylinder is closely related to the delinting efficiency and quality. If the torque is in a good range, the delinting efficiency and quality will also be very good. The experiment started with an initially torque of 76 Nm and the reference was settled to 140 Nm. After the transitory regime, the PID controller reached the set point. It is shown in Fig.6. From the figure, we know that the controller is able to reject the load disturbance effect and keep the cylinder in good condition.

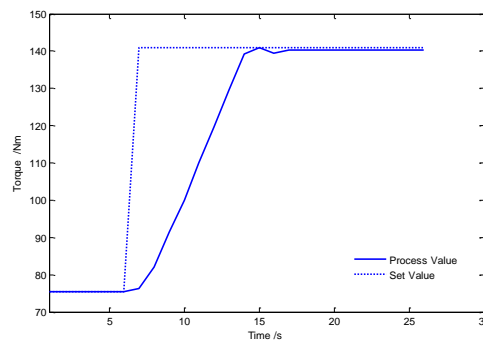

Fig.6 Step response of torque of the third cylinder

## 5 Conclusions

In this study, a design of delinting mechanical measurement control system based on LabWindows/CVI is presented. According to the experiments, the system is proved that it has many advantages such as high testing precision, accuracy, and convenience for delinting experiments. The system can monitor automatically the data of torque of delinting cylinders, feeding motor speed and outlet opening. Because of the strong relationship between the outlet opening and torque of the third cylinder, the system can regulate the outlet opening automatically in order to keep the torque stable. According to the result, the precision of outlet regulation can reach 1mm. This system is also easy to use and provides a good graphical user interface and has higher accuracy, higher efficiency for the real-time control. It can significantly reduce the workload of workers in production.

## Acknowledgment

This research was funded in part by the national science and technology supporting plan (2012BAF07B04). This study is based on work supported by the key laboratory modern agricultural equipment ministry of agriculture, P.R. China.

## References

1. Downing, James D. Apparatus for the foamed acid delinting of cottonseed: US Patent, 4259764[P], 1981-4-7.
2. DR Kincer, DL Kincer, LT Kincer. Mechanical cottonseed delinter: US Patent, 4942643[P], 1990-7-24.
3. C Jones. Method of delinting cotton seed: US patent, 5249335[P], 1993-10-5.
4. G.F.Wang,H.J.Guan. The application research on the production control of dilute acid delinting[J].Industrial Mechatronics and Automation International Conference 2009. Chengdu, 15-16 May 2009, pp.37-40.
5. Zhen Zuo, Jingdong Zuo. Automatic control system for delinter: China patent, 201220150875[P], 2012-12-5.
6. Xingqiao Chen, Shuping Han, Zhaoming Sun,et al. Frequency automatic setting system of a delinter seed feeding mechanism: China patent,203191861U[P],2013.
7. Xuexiu Liang, Zhi Chen, Xiaochao Zhang.et.al. Design and experiment of on line monitoring system for feed quantity of combine harvester[J]. Transactions of the Chinese Society for Agricultural Machinery, 2013, 44(z2):1-6.
8. Xuewen Wei, Aiguo Song. Design of multi-motor control system based on C8051F340[J]. Measurement & Control Technology, 2009, 28(1):38-40.
9. Shifeng Yang, Daudi S. Simbeye. Computerized greenhouse environmental monitoring and control system based on LabWindows/CVI[J]. Journal of Computers, 2013, 8(2):399-408.
10. Fang Yang. Design of power quality analyzer based on LabWindows/CVI[J]. Advanced Materials Research, 2012, 466: 759-762.