

Interval Observer Approach to Output Stabilization of Linear Impulsive Systems

Kwassi Holali Degue, Denis Efimov, Jerome Le Ny

► **To cite this version:**

Kwassi Holali Degue, Denis Efimov, Jerome Le Ny. Interval Observer Approach to Output Stabilization of Linear Impulsive Systems. Proc. 20th IFAC WC 2017, Jul 2017, Toulouse, France. <hal-01508772>

HAL Id: hal-01508772

<https://hal.inria.fr/hal-01508772>

Submitted on 14 Apr 2017

HAL is a multi-disciplinary open access archive for the deposit and dissemination of scientific research documents, whether they are published or not. The documents may come from teaching and research institutions in France or abroad, or from public or private research centers.

L'archive ouverte pluridisciplinaire **HAL**, est destinée au dépôt et à la diffusion de documents scientifiques de niveau recherche, publiés ou non, émanant des établissements d'enseignement et de recherche français ou étrangers, des laboratoires publics ou privés.

Interval Observer Approach to Output Stabilization of Linear Impulsive Systems [★]

Kwassi H. Degue ^{***}, Denis Efimov ^{***}, Jerome Le Ny ^{***}

^{*} *Non-A team @ Inria, Parc Scientifique de la Haute Borne, 40 av. Halley, 59650 Villeneuve d'Ascq, France*

^{**} *Department of Control Systems and Informatics, ITMO University, 49 Kronverkskiy av., 197101 Saint Petersburg, Russia*

^{***} *Department of Electrical Engineering, Polytechnique Montreal and GERAD, Montreal, QC H3T-1J4, Canada.*

Abstract: The problem of output stabilization is studied for a class of linear hybrid systems subject to signal uncertainties: linear impulsive systems under dwell-time constraints. Two problems are considered. First, an interval observer estimating the set of admissible values for the state is designed. Next, an output stabilizing feedback design problem is studied where the stability is checked using linear matrix inequalities (LMIs). To the best of our knowledge, interval observer approach has never been proposed for the stabilization of this class of hybrid systems. Efficiency of the proposed approach is demonstrated by computer experiments for Fault Detection and Isolation (FDI) and Fault-Tolerant Control (FTC) of a power split device with clutch for heavy-duty military vehicles.

Keywords: Interval estimation, Linear impulsive systems and control, Stabilization

1. INTRODUCTION

Impulsive systems are an important class of hybrid systems that include both continuous and discrete event dynamics. The continuous dynamics are generally represented by differential equations and the discrete one by switching laws, which govern discontinuous jumps of continuous states [Goebel et al. 2012, Fichera et al. 2013]. The instants of these jumps can be time-dependent or state-dependent [Branicky 2005, Goebel et al. 2012]. Many systems can be modeled as impulsive ones [Degue et al. 2016b]. Biological systems and intelligent vehicle/highway ones are some examples. Impulsive system stabilization is an important problem treated in the literature [Briat 2013, 2016, Chen et al. 2012b]. When all uncertainty is included in corresponding intervals or polytopes, synthesis of a conventional controller using the estimates of true values of the state may be complicated [Besançon 2007, Meurer et al. 2005]. In such a case the problem of pointwise estimation [Degue and Le Ny 2017] can be substituted by the interval one [Degue et al. 2016a]. Using input-output measurements an observer has to estimate the set of admissible values (interval) for the state at each instant of time [Gouzé et al. 2000]. A major advantage of interval estimation is that it allows many types of uncertainties to be taken into account in the system [Efimov and Raïssi 2015].

Control of impulsive systems has been studied in previous works [Briat 2013, 2016, Chen et al. 2012a, Hetel et al. 2013]. In general in the existing literature, disturbances or

uncertain parameters are such that the design of observers that can converge to the true values of the state is assumed to be possible. The problem of control design of impulsive systems becomes very challenging when one has to take into account the presence of a disturbance or uncertain parameters whose values should be considered to be an interval, rather than a single point measurement. The use of interval observer approach can be a solution in these cases [Efimov et al. 2013, 2015].

This paper sets out to make a contribution at two levels. Firstly, an extension of the results from [Briat 2013] on input-to-state stability analysis for linear impulsive systems is proposed. Secondly, using the interval observer from [Degue et al. 2016b], a stabilizing control design based on interval observers as in [Efimov et al. 2013, 2015] is presented. Since the interval estimates satisfy $\underline{x}(t) \leq x(t) \leq \bar{x}(t)$ for all $t \geq 0$, then the stabilization of the bounds $\underline{x}(t)$ and $\bar{x}(t)$, which are considered as outputs of an interval observer, ensures the same property for the considered linear impulsive system. To the best of our knowledge, the interval observer approach has never been proposed for the stabilization of this class of hybrid systems.

The outline of the paper is as follows. Some basic facts from the theories of interval estimation and hybrid systems are given in Section 2. In Section 3 we investigate the necessary results from hybrid systems robust stability under ranged dwell-time, which are applied in Sections 3 and 5 to design respectively the interval observer and the controller. Finally, the methodology is applied to Fault Detection and Isolation (FDI) and Fault-Tolerant Control (FTC) of a power split device with clutch for heavy-duty

[★] This work was supported in part by the Government of Russian Federation (Grant 074-U01) and the Ministry of Education and Science of Russian Federation (Project 14.Z50.31.0031).

military vehicles in Section 6 in order to demonstrate the efficiency of the developed technique.

2. PRELIMINARIES

The real and integer numbers are denoted by \mathbb{R} and \mathbb{Z} respectively, $\mathbb{R}_+ = \{\tau \in \mathbb{R} : \tau \geq 0\}$ and $\mathbb{Z}_+ = \mathbb{Z} \cap \mathbb{R}_+$. Euclidean norm for a vector $x \in \mathbb{R}^n$ will be denoted as $|x|$, the symbol $|A|$ for a matrix $A \in \mathbb{R}^{n \times n}$ corresponds to the induced matrix norm. The sequence of integers $1, \dots, n$ is denoted as $\overline{1, n}$. The symbols I_n and $E_{n \times m}$ denote the identity matrix with dimension $n \times n$ and the matrix with all elements equal to 1 with dimensions $n \times m$, respectively. For a bounded input $u : \mathbb{R}_+ \rightarrow \mathbb{R}$ the symbol $\|u\|_{[t_0, t_1]}$ denotes its L_∞ norm

$$\|u\|_{[t_0, t_1]} = \sup_{t \in [t_0, t_1]} |u(t)|,$$

if $t_1 = +\infty$ then we simply write $\|u\|$. We denote as \mathcal{L}_∞ the set of all inputs u with the property $\|u\| < \infty$. A matrix $A \in \mathbb{R}^{n \times n}$ is called Metzler if all its elements outside the main diagonal are nonnegative, *i.e.* $A_{i,j} \geq 0$ for $1 \leq i \neq j \leq n$. The vector of the eigenvalues of the matrix A is denoted as $\lambda(A)$.

2.1 Interval relations

For two vectors $x_1, x_2 \in \mathbb{R}^n$ or matrices $A_1, A_2 \in \mathbb{R}^{n \times n}$, the relations $x_1 \leq x_2$ and $A_1 \leq A_2$ are understood elementwise. The relation $P \prec 0$ ($P \succ 0$) means that the matrix $P \in \mathbb{R}^{n \times n}$ is negative (positive) definite, the class of such matrices is denoted as $S_{>0}^n$ ($S_{<0}^n$). Given a matrix $A \in \mathbb{R}^{m \times n}$, define $A^+ = \max\{0, A\}$, $A^- = A^+ - A$ (similarly for vectors) such that the matrix of absolute values of all elements $|A|_{\text{abs}} = A^+ + A^-$.

Lemma 1. [Efimov et al. 2012] Let $x \in \mathbb{R}^n$ be a vector variable, $\underline{x} \leq x \leq \bar{x}$ for some $\underline{x}, \bar{x} \in \mathbb{R}^n$.

(1) If $A \in \mathbb{R}^{m \times n}$ is a constant matrix, then

$$A^+ \underline{x} - A^- \bar{x} \leq Ax \leq A^+ \bar{x} - A^- \underline{x}. \quad (1)$$

(2) If $A \in \mathbb{R}^{m \times n}$ is a matrix variable and $\underline{A} \leq A \leq \bar{A}$ for some $\underline{A}, \bar{A} \in \mathbb{R}^{m \times n}$, then

$$\begin{aligned} \underline{A}^+ \underline{x}^+ - \bar{A}^+ \underline{x}^- - \underline{A}^- \bar{x}^+ + \bar{A}^- \bar{x}^- &\leq Ax \\ &\leq \bar{A}^+ \bar{x}^+ - \underline{A}^+ \bar{x}^- - \bar{A}^- \underline{x}^+ + \underline{A}^- \underline{x}^-. \end{aligned} \quad (2)$$

Furthermore, if $-\bar{A} = \underline{A} \leq 0 \leq \bar{A}$, then the inequality (2) can be simplified: $-\bar{A}(\bar{x}^+ + \underline{x}^-) \leq Ax \leq \bar{A}(\bar{x}^+ + \underline{x}^-)$.

2.2 Stability of hybrid systems under ranged dwell-time

Consider an impulsive linear system with external inputs

$$\begin{aligned} \dot{x}(t) &= Ax(t) + f(t) \quad \forall t \in [t_i, t_{i+1}), i \in \mathbb{Z}_+, \\ x(t_{i+1}) &= Gx(t_{i+1}^-) + g(t_{i+1}) \quad \forall i \geq 1, \end{aligned} \quad (3)$$

where $x(t) \in \mathbb{R}^n$ is the state vector and $x(t_{i+1}^-)$ is the left-sided limit of $x(t)$ for $t \rightarrow t_{i+1}$; $A, G \in \mathbb{R}^{n \times n}$; $f : \mathbb{R}_+ \rightarrow \mathbb{R}^n$, $f \in \mathcal{L}_\infty$ is the input for $t \in [t_i, t_{i+1})$; $g : \mathbb{R}_+ \rightarrow \mathbb{R}^n$, $g \in \mathcal{L}_\infty$ is the input at time instants t_{i+1} for all $i \geq 1$. The sequence of impulse events t_i with $i \in \mathbb{Z}_+$ is assumed to be positively incremental, *i.e.* $T_i = t_{i+1} - t_i > 0$ and $t_0 = 0$.

Theorem 2. Briat [2013] Consider the system (3) with $\|f\|_\infty = \|g\|_\infty = 0$ and a ranged dwell-time $T_i \in [T_{\min}, T_{\max}]$ for all $i \in \mathbb{Z}_+$, where $0 < T_{\min} \leq T_{\max} < +\infty$ are given constants. Then it is asymptotically stable provided that there exist matrices $P \in S_{>0}^n$ and $Q \in S_{>0}^n$ such that for all $\theta \in [T_{\min}, T_{\max}]$

$$G^T e^{A^T \theta} P e^{A \theta} G - P = -Q. \quad (4)$$

The proof of the above theorem is based on the fact that in this case $W(x) = x^T P x$ is a Lyapunov function for (3) at discrete instants of time t_i .

3. ROBUST STABILITY OF HYBRID SYSTEMS UNDER RANGED DWELL-TIME

Following [Dashkovskiy and Mironchenko 2013, Hespanha et al. 2005], robustness with respect to the inputs f and g can be proven (see the definition of the input-to-state stability (ISS) property given in those works).

Lemma 3. Consider system (3) with a ranged dwell-time $T_i \in [T_{\min}, T_{\max}]$ for all $i \in \mathbb{Z}_+$, where $0 \leq T_{\min} \leq T_{\max} < +\infty$ are given constants. Then, provided that there exist matrices $P \in S_{>0}^n$ and $Q \in S_{>0}^n$ such that for all $\theta \in [T_{\min}, T_{\max}]$ the LMI (4) is satisfied, (3) is ISS and the following asymptotic gain is guaranteed

$$\lim_{t \rightarrow +\infty} |x(t)| \leq [\rho_{P,Q,W} \|g\|_\infty + T_{\max}(1 + \rho_{P,Q,W} |G| \varrho(A))] \varrho(A), \quad (5)$$

$$\rho_{P,Q,W} = \frac{\sqrt{\frac{\lambda_{\max}(W)}{\lambda_{\min}(P)}}}{1 - \sqrt{\frac{\lambda_{\max}(P) - \frac{1}{2} \lambda_{\min}(Q)}{\lambda_{\min}(P)}}}, \quad (6)$$

where $W = P + \sup_{\theta \in [T_{\min}, T_{\max}]} 2PGe^{A\theta} Qe^{A^T \theta} G^T P$ and

$$\varrho(A) = \begin{cases} e^{\mu(A)T_{\max}} & \mu(A) > 0 \\ 1 & \mu(A) \leq 0, \end{cases}$$

for $\mu(A) = \max_{i=\overline{1, n}} \lambda(\frac{A+A^T}{2})$ being a logarithmic norm of the matrix A .

This result implies that (3) has bounded solutions for any bounded inputs f and g if the LMI (4) is valid. All proofs are skipped due to the space limitation.

4. INTERVAL OBSERVER

Consider a hybrid (impulsive) linear system

$$\begin{aligned} \dot{x}(t) &= Ax(t) + Bu(t) + f(t) \quad \forall t \in [t_i, t_{i+1}), i \in \mathbb{Z}_+, \\ x(t_{i+1}) &= Gx(t_{i+1}^-) + Du(t_{i+1}) + g(t_{i+1}) \quad \forall i \geq 1, \\ y(t) &= Cx(t) + v(t), \end{aligned} \quad (7)$$

where $x(t) \in \mathbb{R}^n$ is the state vector and $x(t_{i+1}^-)$ is the left-sided limit of $x(t)$ for $t \rightarrow t_{i+1}$; $u(t) \in \mathbb{R}^m$ is the control; $A, G \in \mathbb{R}^{n \times n}$; $B, D \in \mathbb{R}^{n \times m}$; $f : \mathbb{R}_+ \rightarrow \mathbb{R}^n$, $f \in \mathcal{L}_\infty$ is the input for $t \in [t_i, t_{i+1})$; $g : \mathbb{R}_+ \rightarrow \mathbb{R}^n$, $g \in \mathcal{L}_\infty$ is the input at time instants t_{i+1} for $i \geq 1$; $y(t) \in \mathbb{R}^p$ is the output signal available for measurements; $v \in \mathcal{L}_\infty$ is the measurement noise; $C \in \mathbb{R}^{p \times n}$. As before, the sequence of impulse events t_i with $i \in \mathbb{Z}_+$ is assumed to be positively incremental, *i.e.* $T_i = t_{i+1} - t_i > 0$ and $t_0 = 0$.

We need the following Assumptions for system (7)

5. CONTROL DESIGN

Assumption 1. Let $T_i = t_{i+1} - t_i \in [T_{\min}, T_{\max}]$ for all $i \in \mathbb{Z}_+$, where $0 \leq T_{\min} \leq T_{\max} < +\infty$ are given constants.

Assumption 2. There exist matrices $L \in \mathbb{R}^{n \times p}$, $M \in \mathbb{R}^{n \times p}$, $P \in S_{>0}^n$ and $Q \in S_{>0}^n$ such that

i) the LMI

$$(G - MC)^T e^{(A - LC)^T \theta} P e^{(A - LC)\theta} (G - MC) - P = -Q \quad (8)$$

holds for all $\theta \in [T_{\min}, T_{\max}]$;

ii) the matrix $(A - LC)$ is Metzler;

iii) the matrix $(G - MC)$ is nonnegative.

When Assumption 2.i holds, the quadratic form $W(x) = x^T P x$ is a discrete-time Lyapunov function for the LTI discrete-time system $z_{i+1} = e^{(A - LC)\theta} (G - MC) z_i$ for all $\theta \in [T_{\min}, T_{\max}]$ and $i \in \mathbb{Z}_+$ by Theorem 2.

Assumption 3. Let

i) two functions $\underline{f}, \bar{f}: \mathbb{R}_+ \rightarrow \mathbb{R}^n$, $\underline{f}, \bar{f} \in \mathcal{L}_\infty$ be given such that

$$\underline{f}(t) \leq f(t) \leq \bar{f}(t) \quad \forall t \in \mathbb{R}_+;$$

ii) two functions $\underline{g}, \bar{g}: \mathbb{R}_+ \rightarrow \mathbb{R}^n$, $\underline{g}, \bar{g} \in \mathcal{L}_\infty$ be given such that

$$\underline{g}(t) \leq g(t) \leq \bar{g}(t) \quad \forall t \in \mathbb{R}_+;$$

iii) a constant $0 \leq V \leq +\infty$ be given such that $\|v\| < V$.

Assumption 1 is common in the existing literature concerning observer design, and it implies that the intervals of time between switching are lower and upper bounded. Assumptions 2.ii and 2.iii are essential for the approach but are rather restrictive. They can be relaxed using a transformation of coordinates [Raïssi et al. 2012], but such a relaxation will lead to a more complex notation and it is omitted here for brevity. Assumptions 3.i and 3.ii state that the inputs of the hybrid system (7) are known up to some interval errors $\bar{f}(t) - \underline{f}(t)$ and $\bar{g}(t) - \underline{g}(t)$. Assumption 3.iii suggests an upper bound V for the amplitude of the noise v .

Under the introduced Assumptions an interval observer equation for (7) takes the form

$$\begin{aligned} \dot{\underline{x}}(t) &= (A - LC)\underline{x}(t) + Ly(t) + Bu(t) + \underline{f}(t) \\ &\quad - \bar{L}V \quad \forall t \in [t_i, t_{i+1}), \\ \underline{x}(t_{i+1}) &= (G - MC)\underline{x}(t_{i+1}^-) + My(t_{i+1}) \\ &\quad + Du(t_{i+1}) + \underline{g}(t_{i+1}) - \bar{M}V, \\ \dot{\bar{x}}(t) &= (A - LC)\bar{x}(t) + Ly(t) + Bu(t) + \bar{f}(t) \\ &\quad + \bar{L}V \quad \forall t \in [t_i, t_{i+1}), \\ \bar{x}(t_{i+1}) &= (G - MC)\bar{x}(t_{i+1}^-) + My(t_{i+1}) \\ &\quad + Du(t_{i+1}) + \bar{g}(t_{i+1}) + \bar{M}V, \end{aligned} \quad (9)$$

$\forall i \in \mathbb{Z}_+$, where $\underline{x}(t) \in \mathbb{R}^n$ and $\bar{x}(t) \in \mathbb{R}^n$ are the lower and the upper interval estimates for the state $x(t)$, respectively, $\bar{L} = (L^+ + L^-)E_{p \times 1}$ and $\bar{M} = (M^+ + M^-)E_{p \times 1}$.

Theorem 4. [Degue et al. 2016b] Let Assumptions 2.ii, 2.iii and 3 be satisfied. Then in (7), (9),

$$\underline{x}(t) \leq x(t) \leq \bar{x}(t) \quad t > 0 \quad (10)$$

provided that $\underline{x}(0) \leq x(0) \leq \bar{x}(0)$. If $x \in \mathcal{L}_\infty$ and Assumptions 1 and 2.i are valid, then $\underline{x}, \bar{x} \in \mathcal{L}_\infty$.

The idea of this work consists in solving the stabilization problem for the completely known system (9) instead of (7). Under conditions of Theorem 4, if both $\underline{x}(t)$ and $\bar{x}(t)$ converge to zero, then the state $x(t)$ also has to converge to zero, and boundedness of $x(t)$ follows by the same property of $\underline{x}(t)$ and $\bar{x}(t)$. In this case the signal $y(t)$ is treated in the system (9) as a state dependent disturbance.

Corollary 5. Let Assumptions 2.ii, 2.iii and 3 be satisfied, then

$$|y(t)| \leq |C|(|\underline{x}(t)| + |\bar{x}(t)|), \quad \forall t \in \mathbb{R}_+.$$

Hence, one has to stabilize the system (9) uniformly (or robustly) with respect to a Lipschitz nonlinearity y . The control is chosen as a conventional state linear feedback

$$u(t) = \underline{K}x(t) + \bar{K}\bar{x}(t), \quad \forall t \in [t_i, t_{i+1}),$$

$$u(t_{i+1}) = \underline{J}x(t_{i+1}^-) + \bar{J}\bar{x}(t_{i+1}^-), \quad (11)$$

where \underline{K} , \bar{K} , \underline{J} and \bar{J} are four feedback gains to be designed. When substituting the control (11) into (9), it follows that

$$\begin{aligned} \dot{\underline{x}}(t) &= (A - LC + \underline{B}\underline{K})\underline{x}(t) + Ly(t) + \underline{B}\bar{K}\bar{x}(t) + \underline{f}(t) \\ &\quad - \bar{L}V \quad \forall t \in [t_i, t_{i+1}), \end{aligned}$$

$$\begin{aligned} \underline{x}(t_{i+1}) &= (G - MC + \underline{D}\underline{J})\underline{x}(t_{i+1}^-) + My(t_{i+1}) \\ &\quad + \underline{D}\bar{J}\bar{x}(t_{i+1}^-) + \underline{g}(t_{i+1}) - \bar{M}V, \end{aligned} \quad (12)$$

$$\begin{aligned} \dot{\bar{x}}(t) &= (A - LC + \bar{B}\bar{K})\bar{x}(t) + Ly(t) + \bar{B}\underline{K}\underline{x}(t) + \bar{f}(t) \\ &\quad + \bar{L}V \quad \forall t \in [t_i, t_{i+1}), \end{aligned}$$

$$\begin{aligned} \bar{x}(t_{i+1}) &= (G - MC + \bar{D}\bar{J})\bar{x}(t_{i+1}^-) + My(t_{i+1}) \\ &\quad + \bar{D}\underline{J}\underline{x}(t_{i+1}^-) + \bar{g}(t_{i+1}) + \bar{M}V, \end{aligned}$$

and it is necessary to analyse stability of this nonlinear system. Let us introduce $\varepsilon(t) = [\underline{x}^T(t) \quad \bar{x}^T(t)]^T$ and the matrices

$$\begin{aligned} R &= \begin{bmatrix} A - LC + \underline{B}\underline{K} & \bar{B}\bar{K} \\ \underline{B}\underline{K} & A - LC + \bar{B}\bar{K} \end{bmatrix}, \\ S &= \begin{bmatrix} G - MC + \underline{D}\underline{J} & \underline{D}\bar{J} \\ \underline{D}\underline{J} & G - MC + \bar{D}\bar{J} \end{bmatrix}, \\ \delta(t) &= \begin{bmatrix} \underline{f}(t) - \bar{L}V \\ \bar{f}(t) + \bar{L}V \end{bmatrix}, \quad \varsigma(t_{i+1}) = \begin{bmatrix} \underline{g}(t_{i+1}) - \bar{M}V \\ \bar{g}(t_{i+1}) + \bar{M}V \end{bmatrix}, \end{aligned}$$

then one can rewrite the system (12) as

$$\dot{\varepsilon}(t) = R\varepsilon(t) + \delta(t) + \begin{bmatrix} Ly(t) \\ Ly(t) \end{bmatrix} \quad (13)$$

$$\varepsilon(t_{i+1}) = S\varepsilon(t_{i+1}^-) + \varsigma(t_{i+1}) + \begin{bmatrix} My(t_{i+1}) \\ My(t_{i+1}) \end{bmatrix}.$$

Theorem 6. Let Assumptions 1, 2.ii, 2.iii and 3 hold, $\underline{x}(0) \leq x(0) \leq \bar{x}(0)$ and there exist matrices $\underline{K} \in \mathbb{R}^{m \times n}$, $\bar{K} \in \mathbb{R}^{m \times n}$, $\underline{J} \in \mathbb{R}^{m \times n}$, $\bar{J} \in \mathbb{R}^{m \times n}$, $P \in S_{>0}^n$ and $Q \in S_{>0}^n$ such that the matrix inequality

$$e^{R^T \theta} S^T P e^{R\theta} - P + Q = 0 \quad (14)$$

is satisfied for all $\theta \in [T_{\min}, T_{\max}]$, and

$$\begin{aligned} \rho_{P,Q,W} \sqrt{2}|M| + \sqrt{2}T_{\max}(1 + \\ \rho_{P,Q,W}|S|\varrho(R))|L|\varrho(R)|C| < 1, \end{aligned}$$

where $W = P + \sup_{\theta \in [T_{\min}, T_{\max}]} 2PS e^{R\theta} Q e^{R^T \theta} S^T P$. Then system (13) is ISS with respect to the inputs δ and ς .

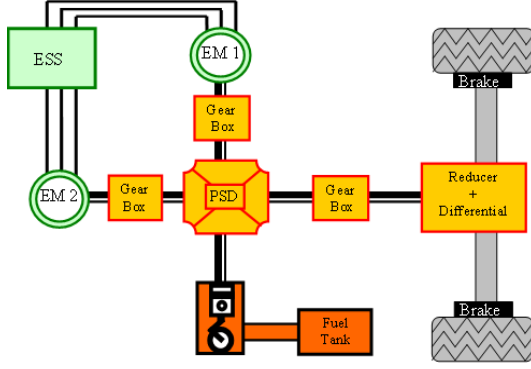

Fig. 1. Series-Parallel HEV Configuration with PSD [Syed et al. 2011]

Remark 7. The design of the control (11) may be affected by computational complexity problems. The feedback gains \underline{K} , \overline{K} , \underline{J} and \overline{J} are chosen a priori to satisfy (14). The LMI (14) can be reformulated using convexity [Boyd et al. 1994].

6. APPLICATION

In this section, the interval observer and the controller that have been designed in this work are applied to Fault Detection and Isolation (FDI) and Fault-Tolerant Control (FTC) of a complex uncertain system.

Hybrid electric vehicles (HEVs) can be classified with respect to their energy flow used for propulsion as either series or parallel [Syed et al. 2011]. Combining these two systems one can obtain the so-called series-parallel HEVs, which have the advantages of these two basic architectures, but have a more complicated structure. The Power Split Device (PSD) that divides the power coming from various power sources into the drivetrain (see Fig.1) plays a major role in the suitable energy management strategy of series-parallel HEVs [Gao and Ehsani 2006]. A hybrid powertrain with a high availability for heavy-duty military vehicles is considered for our application. A series-parallel HEV architecture is considered along with the Ravigneaux geartrain as PSD [Syed et al. 2011].

The considered architecture is comprised of a PSD mounted with shafts connected to two electric machines (EM1 and EM2) through gearboxes, an Internal Combustion Engine (ICE) and transmission with clutch through a gearbox [Syed et al. 2011] (see Fig.2). The role of a clutch is to connect the driving shaft to a driven shaft, so that the driven shaft may be started or stopped at will, without stopping the driving shaft. In conventional vehicles, the clutch allows for power to be transmitted from the ICE to the wheels in order to change the speed ratio using the gearbox [Syed et al. 2011].

The behavior of the clutch is nonlinear, and two different states are considered: the slipped (open) one and the locked (closed) one. During the locked position of the clutch, the system is considered as a single equivalent inertia: the disks are rigidly coupled with each other.

With reference to the notations in Table 1, the locked position of the clutch can be modeled by the following equations

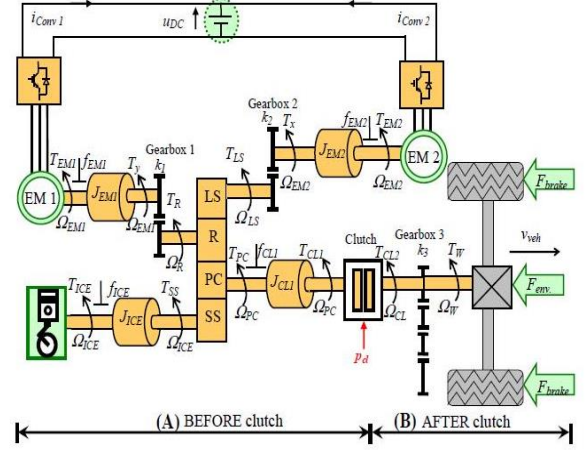

Fig. 2. Considered System Layout [Syed et al. 2011]

Table 1. Parameters used in the Application

| Param. | Meaning |
|---------------|--|
| T_{CL1} | Torque provided upstream of the clutch |
| T_{CL2} | Torque provided downstream of the clutch |
| Ω_{CL} | Speed of the primary shaft after the clutch |
| Ω_{PC} | Speed of the secondary shaft before the clutch |
| f_{CL1} | Friction coefficient of the shaft |
| J_{CL1} | Inertia of the shaft |

$$J_{CL1} \frac{d}{dt} \Omega_{CL} + f_{CL1} \Omega_{CL} = T_{CL2} - T_{PC},$$

$$T_{CL1} = T_{CL2} = T_{CL},$$

$$\Omega_{PC} = \Omega_{CL}.$$

Let us consider a failure mode of the braking phase of the heavy-duty military vehicle with $T_{CL1} = T_{CL2} = 0$, and assume that there is a coefficient $\kappa = 1$, which is added to the friction coefficient f_{CL1} at all instants $t = 3k$ with $k \in \mathbb{Z}_+$. The case where a decrease in normal force leads to an increase in friction is considered. This situation leads to a negative friction coefficient [Thormann 2013]. For the application, the case with $f_{CL1} = -0.5$ and $J_{CL1} = 1 \text{ kg.m}^2$ is considered. Dissipation losses, vibration, abrasion and temperature effects are neglected. Then this failure mode can be represented by the following system with $x(t) = \Omega_{CL}$ and $u(t) = T_{PC}$

$$\dot{x}(t) = ax(t) + bu(t) + f(t) \quad \forall t \neq 3k, k \in \mathbb{Z}_+,$$

$$x(t) = hx(t^-) + du(t) + g(t) \quad \forall t = 3k, k \in \mathbb{Z}_+, \quad (15)$$

$$y(t) = cx(t) + v(t),$$

where a, b, c, d and h are defined as follows

$$a = \frac{-f_{CL1}}{J_{CL1}} = 0.5, \quad b = \frac{-1}{J_{CL1}} = -1,$$

$$c = 10, \quad d = -1, \quad h = \frac{-f_{CL1} + \kappa}{J_{CL1}} = 1.5,$$

and $x(t) \in \mathbb{R}$, $y(t) \in \mathbb{R}$ are the state and the output, respectively. The external disturbances and noises $f(t)$, $g(t)$ and $v(t)$ for simulation are selected as follows

$$f(t) = \beta \sin(2t), \quad g(t) = \delta \sin(t),$$

$$v(t) = V \cos(t),$$

where $\beta = 10^{-3}$, $\delta = 10^{-2}$ and $V = 2$ are given parameters. Thus,

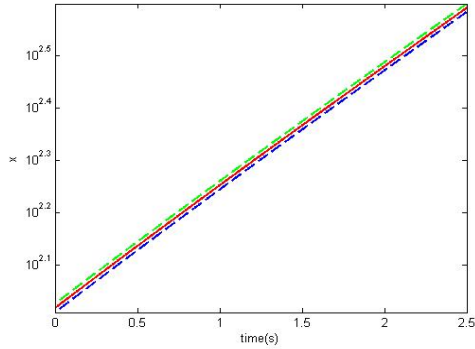

Fig. 3. Results of the simulation of the interval state estimation

$$\begin{aligned} \underline{f}(t) &= -\beta, \quad \overline{f}(t) = \beta, \\ \underline{g}(t) &= -\delta, \quad \overline{g}(t) = \delta. \end{aligned}$$

Assumption 3 is then satisfied. Assumption 2.ii is verified for $l = 0$: $a - lc = 0.5$ is Metzler but not Hurwitz stable. Assumption 2.iii is verified for $m = 0.14$: $g - mc = 0.1$ is nonnegative. By applying Matlab YALMIP toolbox [Löfberg 2004] with discretization to solve the LMIs we found that Assumption 2.i holds for all $\theta \in [0, 4.6051]$. Then the system (9) with the minimum dwell-time $\theta \in [0, 4.6051]$ is ISS. Therefore all conditions of Theorem 4 are satisfied and the interval observer (9) solves the problem of interval state estimation for the Fault Detection and Isolation (FDI). The results of simulation are shown in Fig.3 where the solid line represents the state x , and the dash lines are used for the interval estimates \underline{x} and \overline{x} which are given in the logarithmic scale.

The default on the state is detectable and isolable since x appears in the Analytical Redundancy Relation (15) and the Fault signature matrix is distinguishable. Hence it is required to stabilize the state, which represents the speed of the primary and secondary shaft after and before the clutch during the braking phase of the heavy-duty military vehicle in the considered failure mode. The time response is required to be less than 60 seconds. Equations 14 and 6 are satisfied for $\overline{k} = 0.1$, $\underline{k} = 0.65$, $\overline{j} = 0.1$ and $\underline{j} = -0.15$. The matrices

$$R = \begin{bmatrix} -0.15 & -0.1 \\ -0.65 & 0.4 \end{bmatrix}, \quad S = \begin{bmatrix} 0.25 & -0.1 \\ 0.15 & 0 \end{bmatrix}$$

satisfy all conditions of Theorem 6 for all $\theta \in [0, 4.6051]$ and the controller (11) solves the problem of stabilization of the speed Ω_{CL} . Then the system (7), (9), (11) is ISS with respect to the inputs f and g . The results of simulation are shown in Fig.4 where the solid line represents the state x , and the dash lines are used for the interval estimates \underline{x} and \overline{x} . From these results we can conclude that the speed Ω_{CL} is stabilized and the time response which is $t_R \approx 32$ seconds meet the time response requirements.

7. CONCLUSION

The problems of interval estimation and robust stabilization for a class of linear hybrid systems subject to signal uncertainties have been considered in this paper. The goal of the proposed approach is to take into account the

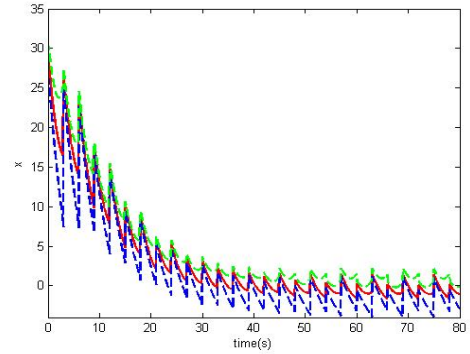

Fig. 4. Results of the simulation of the stabilization

presence of disturbance or uncertain parameters during the synthesis. A new approach for output feedback design is proposed for this class of systems where an interval observer is used instead of a conventional one. Knowing the estimates of the upper and the lower bounds of the state, the problem of output stabilization is reduced to a problem of robust state feedback design. The stability can be checked using linear matrix inequalities (LMIs). Efficiency of the proposed approach is shown on computer simulations for Fault Detection and Isolation (FDI) and Fault-Tolerant Control (FTC) of a power split device with clutch for heavy-duty military vehicles. Future work can focus on nonlinear hybrid systems with parameter uncertainties, and the reformulations of the conditions of the LMIs (14) and (6) using convexity.

REFERENCES

- Besançon, G. (2007). *Nonlinear Observers and Applications*, volume 363 of *Lecture Notes in Control and Information Sciences*. Springer.
- Boyd, S., El Ghaoui, L., Feron, E., and Balakrishnan, V. (1994). *Linear matrix inequalities in system and control theory*, volume 15. SIAM.
- Branicky, M. (2005). *Introduction to Hybrid Systems*. Springer.
- Briat, C. (2013). Convex conditions for robust stability analysis and stabilization of linear aperiodic impulsive and sampled-data systems under dwell-time constraints. *Automatica*, 49, 3449–3457.
- Briat, C. (2016). Dwell-time stability and stabilization conditions for linear positive impulsive and switched systems. *arXiv:1608.02741*.
- Chen, K., Goh, L., He, G., Bhamidi, V., Kenis, P., Zukoski, C., and R.D., B. (2012a). Identification of nucleation rates in droplet-based microfluidic systems. *Chem. Eng. Sci.*, 77, 235–241.
- Chen, Y., Fei, S., and Zhang, K. (2012b). Stabilization of impulsive switched linear systems with saturated control input. *Nonlinear Dynamics*, 69(3), 793–804.
- Dashkovskiy, S. and Mironchenko, A. (2013). Input-to-state stability of nonlinear impulsive systems. *SIAM J. Control Optim.*, 51(3), 1962–1987.
- Degue, K.H., Efimov, D., and Iggidr, A. (2016a). Interval estimation of sequestered infected erythrocytes in malaria patients. In *Proc. of European Control Conference (ECC16)*. Aalborg, Denmark.
- Degue, K.H., Efimov, D., and Richard, J.P. (2016b). Interval observers for linear impulsive systems. In

Proc. of 10th IFAC Symposium on Nonlinear Control Systems (IFAC NOLCOS).

- Degue, K.H. and Le Ny, J. (2017). On Differentially Private Kalman Filtering. In *Proc. of the 20th World Congress of the International Federation of Automatic Control (IFAC 2017)*. Toulouse, France.
- Efimov, D., Fridman, L., Raïssi, T., Zolghadri, A., and Seydou, R. (2012). Interval estimation for LPV systems applying high order sliding mode techniques. *Automatica*, 48, 2365–2371. doi:10.1016/j.automatica.2012.06.073.
- Efimov, D., Raïssi, T., Perruquetti, W., and Zolghadri, A. (2015). Design of interval observers for estimation and stabilization of discrete-time LPV systems. *IMA Journal of Mathematical Control and Information, Oxford University Press (OUP)*, 1–16.
- Efimov, D., Raïssi, T., and Zolghadri, A. (2013). Control of nonlinear and LPV systems: interval observer-based framework. *IEEE Trans. Automatic Control*, 58(3), 773–782.
- Efimov, D. and Raïssi, T. (2015). Design of interval observers for uncertain dynamical systems. *Automation and Remote Control*, 76, 1–29.
- Fichera, F., Prieur, C., Tarbouriech, S., and Zaccarian, L. (2013). Using Luenberger observers and dwell-time logic for feedback hybrid loops in continuous-time control systems. *International Journal of Robust and Nonlinear Control*, 23(10), 1065–1086.
- Gao, Y. and Ehsani, M. (2006). A torque and speed coupling hybrid drivetrain-architecture, control, and simulation. *IEEE Transactions on Power Electronics*, 21(3), 741–748.
- Goebel, R., Sanfelice, R., and Teel, A. (2012). *Hybrid Dynamical Systems: Modeling, Stability, and Robustness*. Princeton University Press.
- Gouzé, J., Rapaport, A., and Hadj-Sadok, M. (2000). Interval observers for uncertain biological systems. *Ecological Modelling*, 133, 46–56.
- Hespanha, J.P., Liberzon, D., and Teel, A.R. (2005). On input-to-state stability of impulsive systems. In *Proc. IEEE CDC-ECC*.
- Hetel, L., Daafouz, J., Tarbouriech, S., and Prieur, C. (2013). Stabilization of linear impulsive systems through a nearly-periodic reset. *Nonlinear Analysis: Hybrid systems*, 7(1), 4–15.
- Löfberg, J. (2004). Yalmip : A toolbox for modeling and optimization in matlab. *Automatic Control Laboratory, ETHZ*.
- Meurer, T., Graichen, K., and Gilles, E.D. (eds.) (2005). *Control and Observer Design for Nonlinear Finite and Infinite Dimensional Systems*, volume 322 of *Lecture Notes in Control and Information Sciences*. Springer.
- Raïssi, T., Efimov, D., and Zolghadri, A. (2012). Interval state estimation for a class of nonlinear systems. *IEEE Trans. Automatic Control*, 57(1), 260–265.
- Syed, S.A., Lhomme, W., and Bouscayrol, A. (2011). Modeling of power split device with clutch for heavy-duty military vehicles. In *Proc. 2011 IEEE Vehicle Power and Propulsion Conference*.
- Thormann, E. (2013). Negative friction coefficients. *Nature Materials*, 12, 468.