

# Deployment Architecture for Energy and Resource Efficient Cyber Physical Systems

Claudio Palasciano, Bastian Thiede, Marco Taisch, Christoph Herrmann

► **To cite this version:**

Claudio Palasciano, Bastian Thiede, Marco Taisch, Christoph Herrmann. Deployment Architecture for Energy and Resource Efficient Cyber Physical Systems. IFIP International Conference on Advances in Production Management Systems (APMS), Sep 2017, Hamburg, Germany. pp.159-167, 10.1007/978-3-319-66923-6\_19 . hal-01666178

**HAL Id: hal-01666178**

**<https://hal.inria.fr/hal-01666178>**

Submitted on 18 Dec 2017

**HAL** is a multi-disciplinary open access archive for the deposit and dissemination of scientific research documents, whether they are published or not. The documents may come from teaching and research institutions in France or abroad, or from public or private research centers.

L'archive ouverte pluridisciplinaire **HAL**, est destinée au dépôt et à la diffusion de documents scientifiques de niveau recherche, publiés ou non, émanant des établissements d'enseignement et de recherche français ou étrangers, des laboratoires publics ou privés.



# Deployment Architecture for Energy and Resource Efficient Cyber Physical Systems

Claudio Palasciano<sup>1\*</sup> (0000-0002-9410-9730), Bastian Thiede<sup>2</sup> (0000-0002-2931-0745), Marco Taisch<sup>1</sup> (0000-0003-2016-3571), and Christoph Herrmann<sup>2</sup> (0000-0002-5621-1822)

<sup>1</sup> Politecnico di Milano, Department of Management, Economics and Industrial Engineering, Milan, Italy

<sup>2</sup> Technical University of Braunschweig, Institut für Werkzeugmaschinen und Fertigungstechnik (TUBs IWF), Braunschweig, Germany

**Abstract.** Energy and resource efficient manufacturing has become one of the most relevant research topics, for the increasing attention to sustainable development at planetary level. This work focuses on deployment of a Cyber Physical Production System in a laboratory setting in Technical University of Braunschweig, Institut für Werkzeugmaschinen und Fertigungstechnik (TUBs IWF), with the aim of improving production systems operation in terms of efficiency in resource usage, taking inspiration by the work developed in Politecnico di Milano by some of the authors of this article, focusing on a production system energy aware control, explored so far by means of simulation experiments.

The objective of this article is studying alternative ICT architectures for the CPS-ization of a production line, namely, a serial line, which matches the main requirements needed from Cyber Physical Production Systems (CPPS), machine to machine communication and local processing, in preparation to deployment, with support of state of the art technologies, such as OPC-UA communication. The proposed solution is interesting for industry, as it shows a practical solution for application on the shop-floor of the Cyber Physical Production systems approach in the vision of Industry 4.0.

## 1 Introduction

Energy and Resource Efficient (ERE) manufacturing has become an important research topic, both as industry is one of the major world energy consumers, as well for the need of sustainable development at planetary level [5]. Furthermore, availability of technologies such as Internet of Things (IoT) are paving the way to the vision of Industry 4.0 and Cyber Physical Production Systems (CPS), with important improvements in the efficient usage of energy and resources in manufacturing [7].

---

\* The work has been partially funded by the European Commission, via H2020 Project GA680633 BEinCPPS Business Experiments in Cyber Physical Systems

## 2 Related work

This work focuses on the vision of the Cyber-Physical Production Systems (CPPS), by exploiting embedded systems and network capabilities and proposes i) the application of a novel approach to ERE control of a serial line, based on heuristic rules, and ii) an ICT architecture fit to the application of the proposed control to an actual line used for educational purposes. Related work will be addressed in the next sections.

### 2.1 ERE autonomous machine control

Although production systems performance has been extensively studied over the years, only recently, at factory and production line level, [1], [2], [10] have studied planning and scheduling methods able to level energy consumption peaks to reduce energy related expenses. Among the most interesting contributions, [8] has started to study effective use of machine tool stand-by modes, while [3] and [4] have explored energy-aware switching off-on policies at machine and line level; nonetheless, the existing models are still incomplete: they focus only on energy consumption and are based on statistical models of stochastic inter-arrival times, neglecting availability of real-time data for local processing.

Some of the authors of this article have recently studied [9] an energy-aware control based on heuristic rules for a serial line, based on three basic functionalities: i) each machine builds and continuously updates its digital twin, including upstream buffer and operational states<sup>3</sup>, plus foreseen end of processing; ii) each machine shares its digital twin with the other machines, and iii) when a machine ends processing, depending on its and other machines' state, can autonomously decide its current state, e.g. enacting stand-by mode. This autonomous control has been studied by [9] with simulation experiments in different configurations and with different sets of heuristic rules, and has shown interesting potential resource savings.

### 2.2 CPS digital/physical architectures and communication

The most interesting developments for our work are related to digitisation reference architectures and communication in manufacturing. As [6] puts in, Cyber Manufacturing Systems (CMS) and Industrial Internet of Things (IIoT) are the industrial counterparts of CPS and IoT and are not individual technologies, but are instead an interdisciplinary mixture of mechatronics, computer science, production systems theory and communication. With respect to communication, the CMS infrastructures raise new challenges for communication as information exchange [6]. Furthermore, common "reference architectures [...] for the development of solutions by multiple actors" are needed<sup>4</sup>, as can be the case of CMS. An

<sup>3</sup> We refer to ISA-TR88.00.02 machine and unit states definition, extended with stand-by state - ISA, 67 Alexander Drive, NC USA

<sup>4</sup> <https://ec.europa.eu/digital-single-market/en/digitising-european-industry>

example reference ICT architecture is proposed by the EU project BEinCPPS ([www.beincpps.eu](http://www.beincpps.eu)).

Among the communication standards for CMS, OPC-UA<sup>5</sup> is the most promising standard architecture at application layer for connection of an automation cell with the factory level, integrating machinery and workstations.

### 3 Aim of the research and approach

This work focuses on deployment of a Cyber Physical Production System, based on the autonomous control studied by [9], in a laboratory setting (Experience Lab) in Technical University of Braunschweig, Institut für Werkzeugmaschinen und Fertigungstechnik (TUBs IWF), with the aim of improving production systems operation in terms of efficiency in resource usage, and leads to the following research items, discussed in below sections: section 4.1: system requirements for autonomous control in the line; section 4.2: data and communication structure; section 4.3: alternative deployment architectures.

## 4 Research findings

### 4.1 System configuration and requirements

The line studied in this work, used for educational and training purposes, is composed by machine modules (including drilling, press, heating tunnel) linked by transfer line (transport belt system + RFID). Each module is equipped with Siemens PLCs, providing communication over industrial Ethernet and sensors for energy and compressed air consumption monitoring. Each machine module, by sharing its digital twin with the other modules, should be able to change state to stand-by when possible, in order to save resources, such as energy and compressed air.

### 4.2 Conceptual model of the system under study and autonomous control

Table 1 shows the main elements of digital twin data structure of each machine  $i$  in the serial line.

Figure 1 shows the conceptual model of the cyber physical system that builds up one generic machine. The model is built in Modelio ([www.modelio.org](http://www.modelio.org)) with SysML, a specialized language for System Engineering design, development and validation, and is represented by an Internal Block Diagram, showing the main components and the information data exchange among them.

The state of each machine (i) must be updated depending on the following events: a) entry of a part into upstream buffer (i); b) entry of a part into machine (i); c) exit of a part from machine (i). The corresponding methods are listed in

---

<sup>5</sup> <https://opcfoundation.org/about/opc-technologies/opc-ua/>

Table 1: Digital twin data structure for ERE control (main elements)

Variable	Description and unit
$PT[i]$	processing time of machine $i$ (exogenous)
$TT[i]$	time threshold for activating stand-by in $i$ (exogenous)
$cjExpectedExitTime[i]$	expected exit time from $i$ of job $j$

the 'ERE control machine  $i$ ' block which updates the variables of the 'Machine  $i$  digital twin' block and receives external data such as presence and expected exit time of an upstream job). Information exchange is also shown with the physical counterpart of machine  $i$ , such the events related to entry and exit from the machine and buffer and with the environment, such as exogenous parameters processing time (PT).

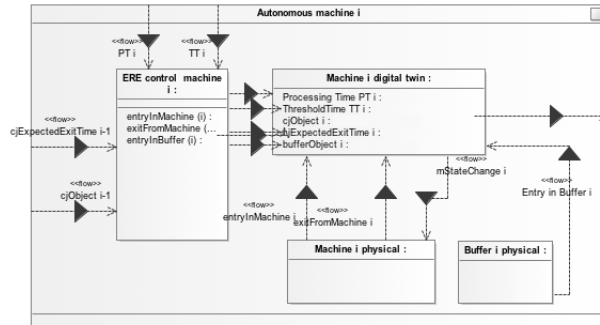

Fig. 1: SysML internal block diagram of Autonomous machine  $i$

The proposed ERE control has been studied with different heuristic rules sets; for the scope of this article we will study the CurrentJobAware (CJA) policy proposed in [9], which is based on the comparison between the time interval available for machine  $i$  after end processing before next job arrival and the threshold time (TT), over which it is feasible and convenient to switch machine  $i$  to stand-by (as proposed by [8]). The difference, if positive, triggers stand-by mode transition.

## 5 Conceptual design of the ICT architecture for the CPS-ized line

### 5.1 Centralized and distributed approaches

In order to deploy the CJA to an actual production line, two approaches are considered: a centralized execution of CJA policy on a single computer or server and a distributed execution of the policy directly on the affected PLC of the machine.

A central approach has several advantages. The overall architecture is simple. Due to the clear distinction of tasks and competencies, the maintainability

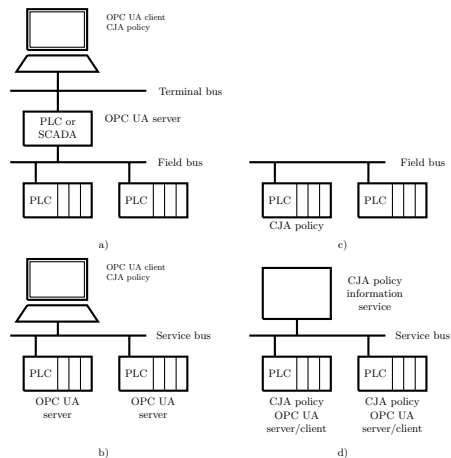

Fig. 2: Considered implementation options for CJA policy

is increased. Since all digital twins are on a single computer, the amount of exchanged data is considered small and communication between digital twins is instant. Despite the increased maintainability, a single point of failure is introduced in the system.

Using a distributed approach may appear more reliable. On the other hand, the amount of exchanged data may be increased since each PLC communicates with each other. Furthermore, in a changing setting, each PLC has to be reconfigured in order to execute the CJA policy correctly. The implementation of a subsidiary information service is suggested to overcome this problem and publish updated configurations to the PLCs. A failure in the information service does not directly lead to downtimes on machines since the policy itself is executed on the PLC.

However, in both cases further backup policies are required in order to ensure an operational mode in case of a system failure (e.g. bus error, CJA policy stopped working). For instance, a heartbeat signal can be used to recognize failures and active the backup policy, e.g. leaving standby mode. In case of a central approach, the CJA policy may be extended by a redundancy system to increase reliability.

## 5.2 Integration of CJA policy

Depending on the given or desired automation system, multiple deployment options exist. Hereafter, four options are presented. Since a computer based CJA policy execution uses OPC UA for communication, most options are based on this standard.

Figure 2 a) shows a deployment scenario based on large scale plants with a separate field bus and terminal bus for security and reliability. The CJA policy is executed on a computer connected to the terminal bus of the plant. The SCADA system or a PLC providing a OPC UA server is used as broker between digital twins and physical machines. Building on an existing system, this approach does not require new connections between the existing systems.

Alternatively, the computer running the CJA policy can be connected directly to the service bus of the plant (figure 2 b)). As already mentioned, OPC UA

becomes common among PLC vendors, which provides a unified protocol stack for communication with the PLCs regardless of its vendor.

As shown in figure 2 c), the CJA policy can be implemented on a single PLC. Unless the PLCs are not already connected, no further connections are required. Communication can be based on a vendor specific or common protocol.

The last considered scenario deploys the CJA policy on each PLC of the machines (figure 2 d)). In this scenario, OPC UA can be utilized for communication or a common vendor specific protocol is used in case of a heterogeneous setup. The implementation of a subsidiary information service is suggested as described in 5.1.

### 5.3 On-going experimentation

We are currently experimenting the central approach option (see Figure 2 a) deployed in i) an OPC UA server, implementing the data structure presented in section 4.2, deployed into the IWF Experience Lab and ii) a CJA policy deployed in a OPC UA client on a laptop computer. OPC UA server is implemented on SCADA System SIMATIC WinCC<sup>6</sup> while the OPC UA client exploits Open Source OPC UA implementation open62451 (<https://open62541.org>).

The system is composed by five machines in a serial line, with parameters and energy profile as in Table 2. In this first experiment phase, the signals coming from the line (such as part finished, processing time left and consumed energy) are simulated by a WinCC program running on a personal computer.

Table 2: Machine parameters and energy profile

Parameters	Power consumption
Mean PT $[i] = 15$ s	Execute power $[i] = 20$ kW
Sigma PT $[i] = 4$ s	Stand-by power $[i] = 1$ kW
TT $[i] = 3$ s	Idle power $[i] = 10$ kW
Ramp-up time $[i] = 2$ s	Ramp-up power $[i] = 40$ kW

In the first experiment set-up, besides showing a first validation of the solution, with the CJA policy controlling only the fourth machine in the line we aimed at checking out step by step the correct triggering of the CJA policy. The experiment has been run with an inter-arrival time (IAT) of 30 seconds, obtained by having all parts to be produced loaded on the first machine buffer at the beginning of the run, with a first machine processing time of 30 seconds. We have run four test runs by varying the number of parts produced from 2 to 20 parts. Output of the test run is the total make-span MS (s) and the total energy consumption of machine 4 (CE<sub>n</sub>) on which the CJA policy is implemented.

<sup>6</sup> <http://w3.siemens.com/mcms/human-machine-interface/en/visualization-software/scada/simatic-wincc/Pages/default.aspx>

The current line configuration, with a machine saturation around 50%, allows 15 seconds available time (due to difference between average cycle time and processing time) to trigger the CJA policy nearly each cycle. On the other hand, the energy profile is characterized by interesting trade off between idle mode and standby overall energy consumption, as a stand by cycle generates each time a power up cycle, with energy consumption peak of 40 kWh for 2 seconds. Table 3 shows results of first four test runs (where CEn=Consumed energy, MS = make-span):

Table 3: First test run results

Test run	Parts (nr)	CEn CJA (kWh)	No	MS CJA (s)	No	CEn CJA (kWh)	MS CJA (s)	CEn delta(%)	MS delta (%)
Run1	2	0.46		132		0.25	137	-45 %	+3.8%
Run2	4	0.73		196		0.51	209	-31 %	+6.6%
Run3	10	1.51		377		1.18	380	-22 %	+0.8%
Run4	20	2.86		699		2.43	703	-15 %	+0.6%

The first test runs are promising: energy saving could be in the long run more than 15% of the baseline, even in a system affected by disturbances, considering as well the trade off between idle time and standby + power up energy consumption, while running on one machine only. Furthermore, it appears that the make-span might be increased maximum to 6%, which can be reduced easily by more advanced versions of CJA policy, able to trigger a power-up state change in advance (e.g. 2 s), to have the machine ready in idle mode right when needed.

We are currently extending each of the four test run, such as running the same run more times while allowing different disturbances series to affect the system, and then averaging the results in order to get more sensible assessment of the experiment values reported in Table 3.

## 6 Conclusions and further steps

This work discusses two alternative approaches, centralized and distributed, for the deployment of the ERE autonomous control under study in the TUBs IWF Experience Lab, evidencing their characteristics and drawbacks, in terms of maintainability and reliability. For this, deployment scenarios with different configurations options, leading to different degrees of centralization have been identified. The work is based on state of the art methods and tools, such as OPC-UA communication and model based design (SysML), as proposed by previously cited EU project BEinCPPS.

The centralized approach appears to be easier for students able to work with tools such as MatLab, but should be deployed by taking into account disturbances and synchronization problems. The distributed approach based on local



processing in embedded systems, might be more reliable and interesting from an industrial point of view, but needs more efforts.

The first performed test runs are promising, as they show CJA policy can obtain significant energy savings, potentially with no substantial effect on the line productivity, even with a simple version of the ERE control running only on one machine of the line. Limitation of the experiments run so far are that we have performed only one test run for each combination of system configuration and parts produced and the design of experiment should be extended to accommodate more system parameters variations (e.g. interarrival times and threshold time).

Further steps for this work, besides completing a full design of experiment to study the behaviour of the CJA policy on the whole line, include further implementation, experimentation and evaluation of the CJA policy and of the alternative ICT architectures discussed in this article, such as the distributed approach (e.g. figure 2, option d), with extension of experiments to other potentially interesting sets of ERE heuristic rules, including disturbances/failures, and, finally, study of the proposed approach to more complex production configurations, such as flow shops or job shops. Furthermore, possible field of research is the study of how each machine can autonomously identify its expected processing time and threshold time, taken in this work as exogenous parameters.

## References

1. Bruzzone, A., Anghinolfi, D., Paolucci, M., Tonelli, F.: Energy-aware scheduling for improving manufacturing process sustainability: A mathematical model for flexible flow shops. *CIRP Annals-Manufacturing Technology* 61(1), 459–462 (2012)
2. Fink, R.: A priority rule based multi criteria scheduling framework for energy efficiency aware detailed production planning. In: *Industrial Electronics Society, IECON 2013-39th Annual Conference of the IEEE*. pp. 7508–7512. IEEE (2013)
3. Frigerio, N., Matta, A.: Energy efficient control strategy for machine tools with stochastic arrivals and time dependent warm-up. *Procedia CIRP* 15, 56–61 (2014)
4. Frigerio, N., Matta, A.: Analysis of an energy oriented switching control of production lines. *Procedia CIRP* 29, 34–39 (2015)
5. Garetti, M., Taisch, M.: Sustainable manufacturing: trends and research challenges. *Production Planning and Control* 23(2-3), 83–104 (2012)
6. Jeschke, S., Brecher, C., Song, H., Rawat, D.: *Industrial Internet of Things: Cyber-manufacturing Systems*. Springer Series in Wireless Technology, Springer International Publishing (2016), <https://books.google.de/books?id=zhRADQAAQBAJ>
7. Lee, E.A.: Cyber physical systems: Design challenges. In: *Object Oriented Real-Time Distributed Computing (ISORC), 2008 11th IEEE International Symposium on*. pp. 363–369. IEEE (2008)
8. Mouzon, G.C.: Operational methods and models for minimization of energy consumption in a manufacturing environment (2008)
9. Palasciano, C., Taisch, M.: Autonomous energy-aware production systems control. In: *Proceedings of the XXI Summer school "Francesco Turco"*. AIDI- Industrial Systems Engineering association (September 2016)
10. Schultz, C., Sellmaier, P., Reinhart, G.: An approach for energy-oriented production control using energy flexibility. *Procedia CIRP* 29, 197–202 (2015)