

# Capability-Driven Digital Service Innovation: Implications from Business Model and Service Process Perspectives

Hasan Koç, Kurt Sandkuhl

► **To cite this version:**

Hasan Koç, Kurt Sandkuhl. Capability-Driven Digital Service Innovation: Implications from Business Model and Service Process Perspectives. 10th IFIP Working Conference on The Practice of Enterprise Modeling (PoEM), Nov 2017, Leuven, Belgium. pp.126-140, 10.1007/978-3-319-70241-4\_9. hal-01765248

**HAL Id: hal-01765248**

**<https://hal.inria.fr/hal-01765248>**

Submitted on 12 Apr 2018

**HAL** is a multi-disciplinary open access archive for the deposit and dissemination of scientific research documents, whether they are published or not. The documents may come from teaching and research institutions in France or abroad, or from public or private research centers.

L'archive ouverte pluridisciplinaire **HAL**, est destinée au dépôt et à la diffusion de documents scientifiques de niveau recherche, publiés ou non, émanant des établissements d'enseignement et de recherche français ou étrangers, des laboratoires publics ou privés.



# Capability-driven Digital Service Innovation: Implications from Business Model and Service Process Perspectives

Hasan Koç, Kurt Sandkuhl

University of Rostock, Institute of Computer Science, 18055 Rostock, Germany  
{hasan.koc, kurt.sandkuhl}@uni-rostock.de

**Abstract.** Today's enterprises face the need to develop user-specific solutions due to the disruptive technologies and competition in the market. Intangibility of services and service-orientation fosters creation of flexible solutions by innovating business models, service processes and service products. Capabilities are perceived as measuring indicator of service orientation in enterprises and one requirement for business model innovation. This paper investigates how design of capabilities can help enterprises to offer novel services. To do so, we analyze the degree of innovation before and after applying the capability-driven development (CDD), which is a methodological and technological enterprise modelling approach. Based on observations from two industrial cases affected from the main forces that disturb the business terrain, the paper concludes that CDD helps enterprises to innovate their digital services by causing changes mainly on business model and service process levels.

**Keywords:** Capability-driven Development, Digital Business, Digital Services, Business Model Innovation, Service Innovation, Capability Modelling, Context Modelling

## 1 Introduction

We are living in an economy that is characterized by rapid change and digitalization. The penetration of IT in our everyday life calls for a transformation from an information to a digital society. Digital economy is growing worldwide and seen as an important driver of innovation and competitiveness. Business models undergo a digital transformation to seize the opportunities provided by the current paradigms, such as Internet of Things (IoT), Sensing Enterprises and Industry 4.0 [1].

Service-oriented way of thinking in the business caused growth of the service economy, which necessarily had a vital impact on the business processes and culture of the organizations. The intangible nature of services, the pace of the disruptive technologies and competition in the market require developing customized, user-specific solutions. In a market offering services to the consumers of the digital society, the enterprises must know their digital customers, understand their preferences and are thus seeking ways that would allow them to provide them with innovative services.

Service innovation is closely related with the innovation of business models and service processes [2]. Business model innovation concerns evolving one or more components of a business model. According to one study, financial outperformers put twice as much emphasis on business model innovation as underperformers [3].

One primary requirement for business model innovation and a measuring indicator of service orientation is enterprise capabilities [4]. Seelos and Mair define business model as “a set of capabilities that is configured to enable value creation consistent with either economic or social strategic objectives” [5]. Organizational capabilities to generate innovative services are seen as a vector of competitiveness [6]. However, the relationship between business model innovation and service innovation in the context of digitalization [7] as well as the role of capabilities is under-researched. Against this background, the main research question investigated in this paper is how capability-based design can contribute to digital service innovation. Section 2 summarizes the related work in the field of service innovation, business model innovation and the role of capabilities. Then, section 3 illustrates two case studies from two distinctive industries. In section 4, we show how capability-based design enables digital service innovation of the aforementioned organizations, particularly by introducing changes on business model and service process levels. Section 5 discusses the findings and section 6 concludes the work.

## 2 Related Work

### 2.1 Service Innovation

The rise of the service economy addresses the need of designing new organizational models to support service innovation. Increased competition, fast-paced markets and digitalization increases the pressure to generate continually new and innovative services. In the light of disruptive innovations, [8] identify three main forces that disturb the business terrain, namely “de(regulation) & trade liberalization, technology and modularity & standardized interfaces”.

Service innovation is “the rebundling of diverse resources that create novel resources that are beneficial (...) to some actors in a given context” [9]. In this paper, service innovation is interpreted as the design or improvement of service concepts to satisfy unmet customer needs [2]. Different typologies and modes of service innovation are present in the literature. [10] defines four dimensions, service concept, client interface, service delivery system, and technology. [11] distinguish between four types of IT service innovations, administrative process, technological process, technological service, and technological integration innovations. Wang et al. argue in their work that service innovation embraces *business model*, *service process* and *service product innovation* [2]. The authors also investigate the dominant and supporting modes of service innovation. After analyzing a total of 69 innovation cases, they conclude that (service) product innovation rarely occurs standalone, rather it happens jointly with (service) product innovation.

In this work, we use the service innovation criteria of Wang et al. as the authors analyze various service innovation typologies and derive their framework based on the

existing proposals [2]. Further, we argue that capability-based design can help enterprises to innovate their services, as a result of which business models could be changed. This view is also reflected in Wang et al.'s framework, which makes it fit for the purposes of this paper.

The distinguishing aspect of the services is that their production and delivery are simultaneous. As such, we limit the investigation in this study on the two modes, namely *business model innovation* and *service process innovation*, which are illustrated in Table 1 and explained in the next section.

**Table 1.** Service innovation criteria, adapted from [2]

Business model innovation	Service process innovation
<p><i>Should satisfy at least one of the following criteria</i></p> <ul style="list-style-type: none"> <li>• Substantial change in the way in which revenues and profits are earned, e.g., change of value proposition, cost structure, and revenue streams</li> <li>• Drastic change of partner/ customer relationships</li> <li>• Can either create a new market or allow the company to enter into a totally different market</li> <li>• Platform innovation, which builds new customer/ partner relationships</li> </ul>	<p><i>Should satisfy at least one of the following criteria</i></p> <ul style="list-style-type: none"> <li>• Significant changes in the way information is exchanged between a customer and a service provider</li> <li>• Significant change of the interface between the service provider and its clients</li> <li>• Significant change of the back-office processes,</li> <li>• Significant change of the organizational structure</li> </ul>

## 2.2 Business Model Innovation, Service Process Innovation and Capabilities

The term business model has been defined in the literature in different ways, yet the definitions seem to accentuate the quintessence and method of doing business. For instance, [12] state “a business model is the combination of, who‘,what‘,when‘,where‘, ,why‘, ,how‘, and ,how much‘ an organization uses to provide its goods and services and develop resources to continue its efforts”. [13] argue “a business model describes the rationale of how an organization creates, delivers, and captures value” Likewise, [14] interprets the business model as “the heuristic logic that connects technical potential with the realization of economic value”.

The manifold definitions of the term caused problems when investigating the business model innovation aspect. Particularly, researchers and practitioners posit different views about when something is a minor business change and when it is an innovation. For instance, [15] state “innovation becomes business model innovation, when two or more elements of a business model are reinvented to deliver value in a new way”. Other argue that business model innovation refers to changing at least one of a business model’s constituting elements [16], the change does not need to be groundbreaking and disruptive. From a service-oriented perspective and for this paper’s

purposes, we position ourselves in line with the second view. We argue that business model innovation concerns changes in the way value is delivered to or co-created with the customer by means of forming new partnerships and new activities [4].

Service process innovation concerns incremental improvements to an existing delivery process which lead to new ways of meeting customer needs [17, 18]. Such processes include both service delivery activities as well as back-end tasks supporting the service delivery. Innovation in the service processes is argued to contribute to the co-production of the services and enhance the quality of the customer journey [2].

Service orientation in business models can increase competitive advantage [19] and their innovation is key to firm performance. The connection between business models and service process innovation can be strengthened with the organizational capabilities, which are perceived as “both the primary requirement for business model innovation and a measuring indicator of service orientation” [4]. Management and design of the capabilities is a promising approach to tackle the challenges of dynamic environments. One proposal in that sense is the capability-driven development (CDD) approach, which received attention in IS lately [20]. CDD approach consist of two main artefacts:

- CDD methodology. A methodology consisting of a number of upper-level method encompassing three key perspectives of organizational design – Enterprise Modeling, context modeling, and pattern modeling. Further method components concern support decision making for capability modeling and run-time adjustments modeling. CDD methodology defines a capability as “an ability and capacity that enables an enterprise to achieve a business goal in a certain context” [21]. Accordingly, a capability consists of the digital services offered to the customers, business goals that are realized by delivering this digital service as well as the potential deployment contexts of the digital services. The CDD methodology helps to systematically model those aspects from a conceptual point of view.
- CDD environment. The methodology is supported by the CDD environment, which comprises of a number of tools. Capability Design Tool (CDT) incorporates context modelling, goal modelling and business process modelling modules. Capability Context Platform (CCP) monitors the contextual values at run-time as well as a Capability Delivery Navigation Application (CNA) enables adjustments in line with the service delivery context and reusable best practices. Capability Delivery Application (CDA) retrieves adjustment information from CNA on demand or on schedule [22].

The innovation potential of CDD have been investigated in [23]. Our work follows a similar line, yet does not limit the innovation potential to business models. It rather inspects the innovation on digital services level, which requires analyzing the changes also on service process layers.

### **3 Application Cases**

For the purposes of this study, we collected data by performing a qualitative case study, which focuses on the introduction of the CDD approach for an enhanced digital service delivery (cf. section 3.1 and 3.2). To have a deeper understanding of service

provision and the effects of the CDD approach in the enterprises, we elaborated the findings further by using document-centric techniques and structured interviews. The former concerns visiting the premises of the two organizations (partly in the context of a student project), modelling their way of working and analyzing the secondary data. Such data can include customer specifications, policies, guidelines, service level agreements, documents explaining the organizational processes, the structures, roles, task allocations and best practices. The interviews were performed both on executive (service manager, enterprise architect) and operational (knowledge worker) levels [24, 25].

### **3.1 Utility Industry**

The SIV group is a vertically integrated German enterprise that specifically serves the utility industry and is challenged by the changing regulations. The group operates in two fundamental roles in the market. As an independent software vendor (ISV), SIV.AG develops and distributes the industry-specific ERP platform kVASy®. Considering the rising complexity of the market, public utilities consider outsourcing of their business processes to external service providers. In its business service provider (BSP) role, SIV Utility Services GmbH offers such services for clients running kVASy®.

This paper focuses on the business unit model of BSP, i.e. a business model defined on a specific level for business units of a corporate [26]. The key value proposition is the support of market communication, i.e. business-to-business interactions that deal with the exchange of data between market partners. Market communication requires the processing of bulk data that are transmitted from one market partner to another within a single EDIFACT-formatted file. Exchange of data may easily get into conflict with other data, which requires the initiation of a clearing procedure to complete the communication process. Currently, BSP offers clearing services with costly and manual interaction of knowledge workers. The clearing procedure is usually defined in a handling instruction, i.e. a contractual agreement specifying the clearing terms between the BSP and the client. Yet, there is no process automation nor the clearing procedures are executed in a business process management (BPM) engine. Furthermore, as the handling instructions are client-specific, the contextual aspect of its content must be continuously checked by the knowledge worker. This situation does not allow dynamic changes to service delivery (cf. Figure 1a). Influenced mainly from the regulation and technology forces, the company needs to design innovative digital services and extend the choice space of its customers.

### **3.2 eGovernment**

everis is a multinational consulting firm providing business and strategy solutions, application development, maintenance, and outsourcing services. The everis application case concerns the service portfolio provisioning in eGovernment sector and focuses on the services provided to municipalities, which are then used by citizens and companies. Everis has a SOA platform consisting of a service catalogue with up to 200

e-services of automated (consumed completely online), semi-automated or non-automated nature. During service provision, different factors and actors involved need to be taken into account, e.g. diverse public administration's laws, regulations, calendars, types of events, weather as well as various technological tools.

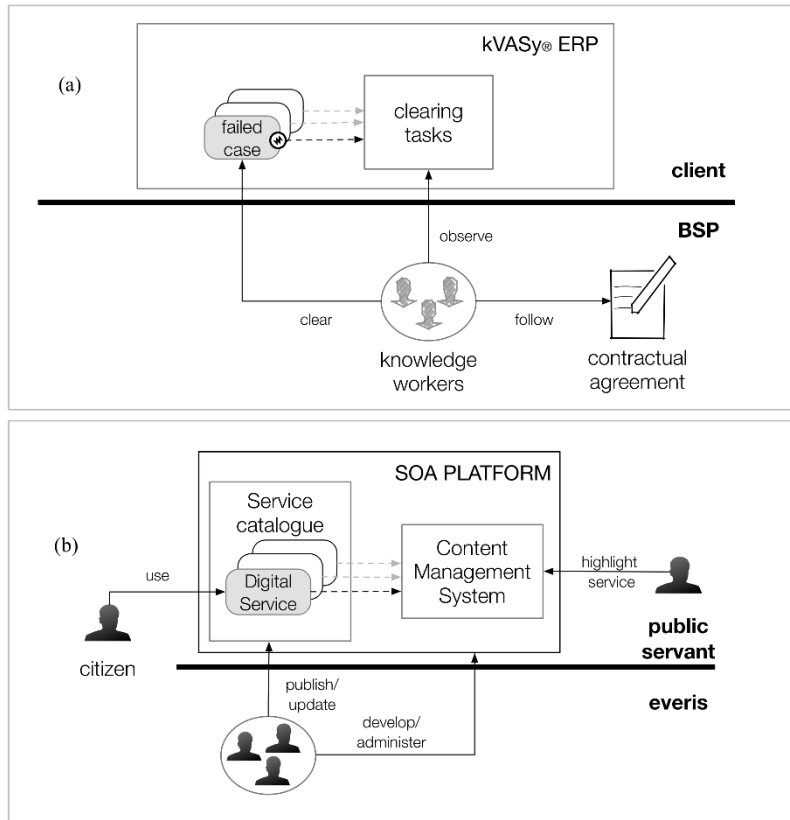

**Fig. 1.** Simplified business architectures in the utility (a) and eGovernment (b) cases [27]

This paper elaborates on the promotion of digital services in a municipality web page. Each municipality is responsible for deciding which services are offered through their home pages. Public servants in the municipality have access to the back office applications in the SOA platform and configure them to highlight a service (cf. Figure 1b). This example of a non-automated service is termed as service promotion. Depending on the municipality, parameters affecting service promotion may change. Currently, those parameters are managed manually; hence costs for exposing the right service is usually high, and also under-exploitation of services may occur. Motivated by the opportunities resulting from and problems created by technology forces, everis envisions designing innovative solutions that are applicable to all municipalities.

## 4 CDD and Digital Service Innovation

Service innovation has three modes, business model, service process and service product innovation (cf. Table 1) [2]. In this study we investigate how capability-driven development contributes to the first two modes.

Introducing CDD to SIV involved performing the CDD methodology and implementing the results within the CDD environment. The methodology helped the company stakeholders to identify the BSP's core capability, i.e. context-aware case clearing. Moreover, a large number of activities performed by the knowledge workers when clearing a case have been documented, best practices have been identified. From a business model innovation perspective, this is crucial as identifying and strengthening core competencies explain why the service quality differs amongst the firms that follow the same business model [4].

The capability models have been designed and implemented within the CDD environment. The CCP served as a business sensor, communicating the changes from the contextual sources with the CNA. The CDT incorporated the capability model consisting of context, goal, business process and pattern models as well as the algorithms for an adjustable solution at runtime. The capability model is deployed to the CNA, which is in the position of deciding whether to clear a case, and if yes, how. The solution is forwarded to the CDA, which incorporates the business process models and solution patterns. If human interaction is required, the knowledge workers can be engaged in clearing at that point. The digitalized solution architecture is shown in Figure 2. The arrows represent the information flow between different components. Note that the dotted arrows represent actions performed by the participating roles as well as their results on the components.

Business model innovation in SIV group. CDD enables transferring clearing service related activities from manual to partially-automated context-aware services. By providing a multi-tenant platform, the BSP can revise its value creation and extend the choice space for its clients, for instance by allowing them to manage the contractual parameters at runtime, providing them the statistics (e.g. number of cleared cases), enabling them to monitor the current situation (e.g. open tasks). Furthermore, the key resource is not only the knowledge worker in the BSP, but also the client as the co-creator of the service, which can let SIV group to establish better customer relationships. For instance, due to performance monitoring, the client can check whether the decision to outsource/or not outsource a case was reasonable. Consequently, substantial changes on business model level is expected (cf. Table 2).

Service process innovation in SIV group. One substantial difference between the current and the to-be solution is that the latter transforms the informal contract attributes into machine-processable quantities. In this respect, application of CDD enables both the BSP and the client to sign in the CNA and define its own contractual parameters. Based on the altered parameters, knowledge worker can receive a more prioritized and client-independent list of clearing tasks. Hence, the application is expected to make a significant change in the interface between the BSP and the client. Furthermore, the knowledge worker will be aware of the client context and be supported with an appropriate pattern for the problem at hand. As this directly influences the clearing procedure followed by the knowledge worker, also changes in the back-office processes are envisioned.



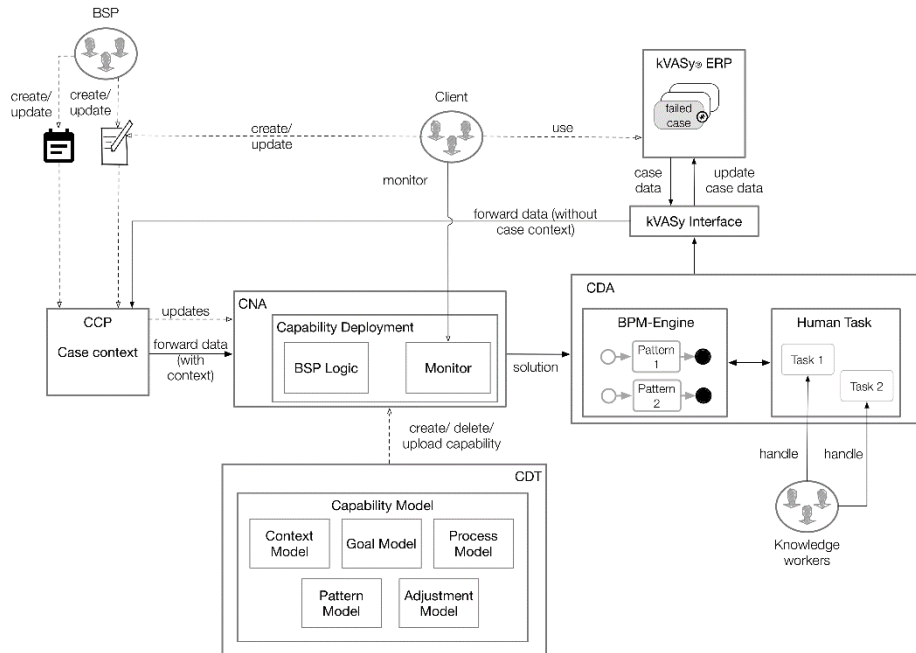

**Fig. 2.** Digitalized solution architecture in the utility industry case

Introducing CDD to everis concerned also application of the CDD methodology and implementing the service promotion service within the CDD environment.

Business model innovation in everis. The service promotion capability allows an automated and context-aware promotion of the most important and relevant digital services in the municipality home pages. In this way, the relevant services will be more accessible for the citizens. This causes a substantial change of the value proposition, as it is not only the SOA platform itself which is being served to the client, but also its ability to compute the most useful service at a certain point of time and to automatize its promotion process (cf. Figure 3. The arrows represent the information flow between different components. The dotted arrows represent actions performed by the participating roles as well as the changes in the service context). As trends in the service usage are propagated to the similar municipalities, everis can extend its license-based revenue model with an effort-based approach, where the municipalities are charged based on the number of promoted services (cf. Table 2). Based on the historical data in the CNA, the service providers can also monitor current relevant services of the municipality and adapt their services accordingly. Thus, customer segmentation in the business model is also expected to change.

Service process innovation in everis. Application of the CDD methodology has helped to understand the parameters that affect the decision of a public servant. Within the CDD environment, such parameters whether to promote a service or not could now be captured systematically, which also enables to track back the decision rationale. The innovative aspects in the service process concerned two aspects. First, the public servant's implicit knowledge is formalized as an executable business process.

Necessarily, this minimized public servant's involvement degree in the promotion process. Second, the citizen feedback in social networks impacts the importance of the service, i.e. if the comments are positive, then the service could be highlighted in similar municipalities [24]. This process innovation is manifested on the key resources segment of business model.

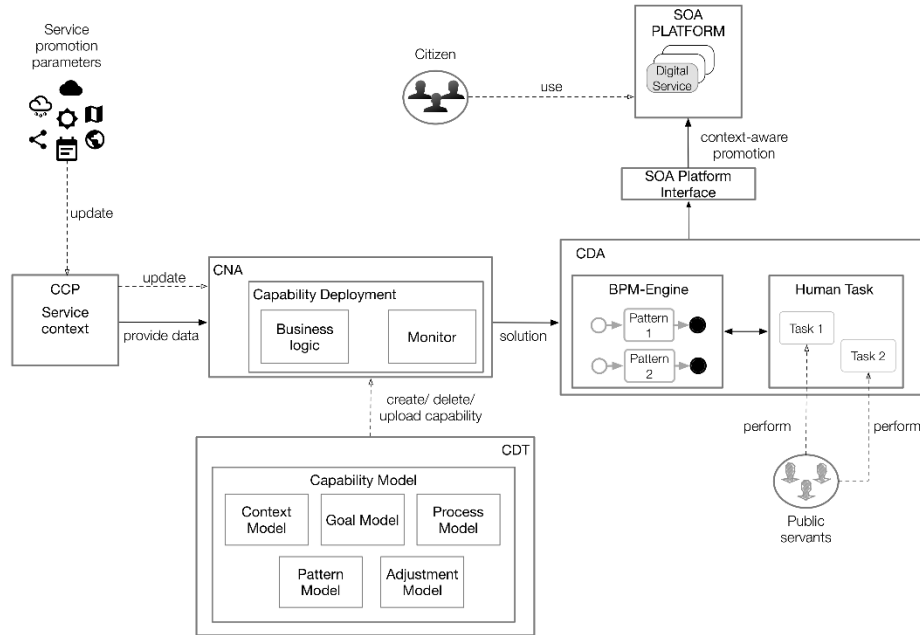

Fig. 3. Digitalized solution architecture in the eGovernment case

Business models communicate the rationale of a company in doing business and can reflect service process or service product-related changes. Hence, we summarize in Table 2 how the business models can change after introducing CDD to the companies.

Table 2. Changes at the business model level

Model block	SIV	everis
Value propositions	before CDD	Knowledge-worker based clearing of the exceptional messages
	after CDD	Context-based clearing of the exceptional messages; Flexible contractual agreements; Monitoring of performance data (e.g. number and types of the cleared/ not cleared cases)
Key activities	before CDD	Message clearing, handling instruction specification (primarily driven by the BSP)
		Publishing new digital services or updating existing ones

	after CDD	Key activities prior to the CDD introduction are formalized and documented. Moreover, they are now driven by both the clients and the BSP	Key activities prior to the CDD introduction are automatized and visible to all participating roles co-creating the value
Key resources	before CDD	Knowledge-workers, know-how on legal aspects; Handling instructions; kVASy	SOA platform; Know-how on municipality properties, legal aspects; qualified employees
	after CDD	Client is also a key resource now, as it co-creates the value by configuring the parameters on the CNA; Case clearing patterns	Extended with citizens and service promotion patterns <sup>1</sup>
Customer segments	before CDD	Public utilities (multi-sided as different market players are supported)	Municipalities
	after CDD	n/a	Extended with external service providers
Customer relationships	before CDD	(Dedicated) personal assistance in case clearing and semi-automated services support; Service hotline & training. Depending on the contract, client may be integrated into the service creation process.	Personal assistance (e.g. information exchange about the service usage); service hotline & training
	after CDD	Although personal assistance still exists, client is now heavily involved in the co-creation of the service	Increase in the rate of automated services; also service co-creation based on citizen feedback
Channels	before CDD	Acquisition of potential clients by sales representative and events; Client-initiated request for BSP support.	In-house sales force National and international projects
	after CDD	Contract templates (from the CDT) and performance data (from the CNA) allows creating additional client acquisition channels	Event-based case reporting, i.e. if the municipality did not book the capability, an email concerning the high service usage is sent [24]
Cost structure	before CDD	Fixed, i.e. costs do not depend on the cases cleared by the knowledge worker	Fixed, i.e. costs remain same when publishing/ updating a service
	after CDD	Economies of scope due to the degree of automation and the possibility to redeploy/reconfigure the capability to different clients	Economies of scope due to pre-defined parameters of municipality properties (e.g. population, size)

<sup>1</sup> <http://bit.ly/2jDd5gl>

Revenue streams	before CDD	kVASy is installed based on the licensing model. Clearing services are billed to the client depending on the contractual agreement.	SOA Platform is deployed and managed based on the licensing model.
	after CDD	Extended with effort-based model, i.e. the client is charged based on the number of cleared cases	Extended with effort-based model, i.e. upon booking the capability, client is also charged based on the number of promoted services
Key partners	before CDD	SIV.AG; Utility market players	everis Project Management Office; Municipalities
	after CDD	n/a	n/a

## 5 Discussion

Capabilities are instruments for competitive advantage in changing environments. In this work, we aimed to show, how capabilities can help enterprises to innovate their services in the age of digital transformation. To do so, we investigated how CDD can contribute to the two service innovation modes, *business model innovation* and *service process innovation* [2].

First dimension concerned the innovation on business model level. In today's digitized economies, business model innovation requires collaboration between different roles participating to the service creation and delivery, blurring the producer-consumer divide. Contextualization and collaboration are perceived as two information-intensive aspects of value creation [28]. CDD allows organizations to consider their business context when designing digital services. We observed that after applying CDD, both SIV group and everis have an emphasized focus on their network and co-create the value with the respective actors in the market. Being aware of their client's current business context should allow them to create new customer segments and channels than speculated in this work as well as to enter into different markets.

Second dimension is the service process innovation. [9] state that innovations are information-centric, are not limited to the organizational boundaries, and focus not on the output, but on the value (experience-centric focus). In terms of information-centricity, capability-driven service innovation emerged based on the formalization of standardized procedures across multiple service provider/client interactions [29], specially where the involvement of knowledge workers and public servants is required. This enables the extension of customers' choice space and in turn the customers become more and more co-producers of the services. Concerning the back-end tasks, providing guidelines to manage process variability, CDD helped the companies to capture and formalize their hitherto undocumented business processes, which allowed enhanced digital service delivery.

We did not perform an extensive analysis on the third mode, service product innovation. The reason behind this limitation is that the service production and

consumption occurs simultaneously in the represented use cases. Moreover, Wang and colleagues identify in a study of 69 service innovation projects only 2 cases, where service product innovation takes place alone (dominant mode) [2]. In terms of service product innovation, we observed that capability-based design may enable SIV group to reposition the “MSCONS clearing” service as “Dynamic clearing center”. Moreover, the ability of clients to configure the contract parameters can be applied to the existing services, e.g. accounting and billing. The services provided by the everis’ SOA platform are affected by changes in requirements, environment and other aspects. Likewise, by applying CDD, everis can modify and reposition its context-dependent services. One example of this is the registration services, which enables citizens to enroll to activities online, e.g. swimming pool and marriage, as detailed in [24]. Both of the examples support the findings of Wang et al. that service product innovation and process innovation often occur jointly, and many “service product innovations are supported by an innovation in the process” [2]. On the other side, in a manufacturing setting, the service product innovation might have been easier to observe, which is not represented in the two use cases.

A similar study about CDD’s innovation potential has been performed in [23]. The innovation aspect in this paper concerns the digital services and investigates not only innovation on a business model level, but also on a service process level. Indeed, we share the authors’ view that capability analysis could help enterprises to innovate their business models and contribute to their findings in two ways. First, although we use a different conceptualization than the authors, capability-driven design still shows potential for business model innovation. Second, by analyzing the business models and also the service processes of an enterprise from a different industry, we hope to decrease the limitation of their work.

## **6 Conclusion and Future Work**

Due to the fast-paced changes in their environment, enterprises are seeking ways to offer user-specific value propositions to their customers. Service economy is an important determinant of economic growth and transformation. This work investigates how capability-based design can help two organizations, SIV from utility industry and everis from eGovernment sector, to innovate their digital services by innovating their business models and service processes. Both companies applied CDD in an international research project, building on which we present our research results.

To assess the impact of CDD on service innovation, we performed interviews with the business stakeholders of the companies both on management and operational level. Based on our observations from those interviews, the delta between the “as-is” and “to-be” situations documented in [27, 30] as well as the findings in [23], we performed the analysis on business model and service process levels. Conclusively, we argue that by using CDD, both companies may offer their innovative services or “capabilities” to their clients in the future. To eliminate the threat to this finding, future endeavors concern including the practitioners on validating CDD’s service innovation potential.

A business model analysis can be performed on generic and specific levels. The analysis performed in this paper concerned the specific level business unit, which is

usually defined for business units of a corporate [26]. The impact of CDD on other levels and their relationship with the business unit level are not analyzed. Hence, another limitation of the findings is the generalizability, which also motivates our further work in the field to applying the CDD and measure its effects on various business model levels. Still, the presented work can give significant input about how capability-driven development can pave the way to create value by extending the choice space of customers [8].

The final limitation concerns both the selection of the service innovation framework proposed by [2] as well as the exclusion of the service product innovation mode. Related work revealed other service innovation typologies, e.g. in [10] or [11]. Although these are not directly related to the innovations on business model level, future research endeavors should concern whether the application of CDD triggers service innovation from the lens of different service modes.

**Acknowledgments.** This work has been performed as part of the EU-FP7 funded project no: 611351 CaaS – Capability as a Service in Digital Enterprises.

## References

1. Leimeister JM, Österle H, Alter S (2014) Digital services for consumers. *Electron Markets* 24(4): 255–258. doi: 10.1007/s12525-014-0174-6
2. Wang Q, Voss C, Zhao X et al. (2015) Modes of service innovation: a typology. *Industrial Management & Data Systems* 115(7): 1358–1382. doi: 10.1108/IMDS-03-2015-0067
3. Zott C, Amit R, Massa L (2011) The Business Model: Recent Developments and Future Research. *Journal of Management* 37(4): 1019–1042. doi: 10.1177/0149206311406265
4. Nair S, Paulose H, Palacios M et al. (2013) Service orientation: Effectuating business model innovation. *The Service Industries Journal* 33(9-10): 958–975. doi: 10.1080/02642069.2013.746670
5. Seelos C, Mair J (2007) Profitable Business Models and Market Creation in the Context of Deep Poverty: A Strategic View. *ACAD MANAGE PERSPECT* 21(4): 49–63. doi: 10.5465/AMP.2007.27895339
6. Barlatier P-J, Bernacconi J-C, Reiter S (2010) Service Portfolio Design for Service Innovation Management: The Case of a Luxemburgish Research and Technology Organization. In: van der Aalst W, Mylopoulos J, Sadeh NM et al. (eds) *Exploring Services Science*, vol 53. Springer Berlin Heidelberg, Berlin, Heidelberg, pp 82–95
7. Ostrom AL, Parasuraman A, Bowen DE et al. (2015) Service Research Priorities in a Rapidly Changing Context. *Journal of Service Research* 18(2): 127–159. doi: 10.1177/1094670515576315
8. Keen P, Williams R (2013) Value architectures for digital business: beyond the business model. *MIS Quarterly* 37(2): 643–648
9. Lusch R, Nambisan S (2015) Service Innovation: A Service-Dominant Logic Perspective. *Management Information Systems Quarterly* 39(1): 155–171
10. Den Hertog P (2000) Knowledge-intensive Business Services as Co-Producers of Innovation. *Int. J. Innov. Mgt.* 04(04): 491–528. doi: 10.1142/S136391960000024X
11. Lyytinen K, Rose GM (2003) The Disruptive Nature of Information Technology Innovations: The Case of Internet Computing in Systems Development Organizations. *MIS Quarterly* 27(4): 557–596
12. Mitchell D, Coles C (2003) The ultimate competitive advantage of continuing business model innovation. *Journal of Business Strategy* 24(5): 15–21. doi: 10.1108/02756660310504924
13. Osterwalder A, Pigneur Y, Clark T (2010) *Business model generation: A handbook for visionaries, game changers, and challengers*. Wiley, Hoboken, NJ

14. Chesbrough H, Rosenbloom R (2002) The role of the business model in capturing value from innovation: Evidence from Xerox Corporation's technology spin-off companies. *Industrial and Corporate Change* 11(3): 529–555. doi: 10.1093/icc/11.3.529
15. Lingardt Z, Reeves M, Stalk G et al. (2009) Business Model Innovation: when the game gets tough, change the game
16. Eurich M, Weiblen T, Breitenmoser P (2014) A six-step approach to business model innovation. *IJEIM* 18(4): 330–348. doi: 10.1504/IJEIM.2014.064213
17. Zomerdijsk LG, Voss CA (2011) NSD Processes and Practices in Experiential Services\*. *Journal of Product Innovation Management* 28(1): 63–80. doi: 10.1111/j.1540-5885.2010.00781.x
18. Boone T (2000) Exploring the Link between Product and Process Innovation in Services. In: Fitzsimmons JA (ed) *New service development: Creating memorable service experiences*. SAGE, Thousand Oaks [u.a.], pp 92–110
19. Peters C, Maglio P, Badinelli R et al. (2016) Emerging Digital Frontiers for Service Innovation. *Communications of the Association for Information Systems* 39(1)
20. Berziša S, Bravos G, Gonzalez TC et al. (2015) Capability Driven Development: An Approach to Designing Digital Enterprises. *Bus Inf Syst Eng* 57(1): 15–25. doi: 10.1007/s12599-014-0362-0
21. Grabis J, Henkel M, Kampars J et al. (2016) Deliverable 5.3: The Final Version of Capability Driven Development Methodology: CaaS - Capability as a Service in digital enterprises, Collaborative Project Number 611351
22. Koç H, Sandkuhl K, Fellmann M (2016) Towards a Flexible Solution in Knowledge-Based Service Organizations: Capability as a Service. In: Borangiu T, Drăgoicea M, Nóvoa H (eds) *Exploring services science: 7th International Conference, IESS 2016, Bucharest, Romania, May 25-27, 2016. Proceedings, vol 247*. Springer, Switzerland, pp 100–111
23. Sandkuhl K, Stirna J (2015) Capability-as-a-Service: Investigating the Innovation Potential from a Business Model Perspective. In: Persson A, Stirna J (eds) *Advanced Information Systems Engineering Workshops: Caise 2015 International Workshops, vol 215*. Springer-Verlag New York Inc, Cham, pp 137–148
24. España S, González T, Grabis J et al. (2014) Capability-Driven Development of a SOA Platform: A Case Study. In: van der Aalst W, Mylopoulos J, Rosemann M et al. (eds) *Advanced information systems engineering workshops caise 2014, vol 178*. Springer, [Place of publication not identified], pp 100–111
25. Koç H, Kuhr J-C, Sandkuhl K et al. (2016) Capability-Driven Development. In: El-sheikh E, Zimmermann A, C. Lakhmi J (eds) *Emerging trends in the evolution of service-oriented and enterprise architectures, vol 111*. Springer International Publishing, Cham, pp 151–177
26. Schallmo DRA (2014) Theoretische Grundlagen der Geschäftsmodell-Innovation – Definitionen, Ansätze, Beschreibungsraster und Leitfragen. In: Schallmo DRA (ed) *Kompodium Geschäftsmodell-innovation: Grundlagen, aktuelle ansätze und Fallbeispiele zur erfolgreichen geschäftsmodell-Innovation*. Springer Gabler, Wiesbaden, Germany, pp 1–30
27. Czubyko U, Koç H, Kuhr J-C et al. (2016) Deliverable 2.3: BPO case validation report for the CaaS approach: CaaS - Capability as a Service in digital enterprises, Collaborative Project Number 611351
28. Lusch RF (2007) Marketing's Evolving Identity: Defining Our Future. *Journal of Public Policy & Marketing* 26(2): 261–268. doi: 10.1509/jppm.26.2.261
29. Barrett M, Davidson E, Prabhu J et al. (2015) Service Innovation in the Digital Age: Key Contribution and Future Directions. *Management Information Systems Quarterly* 39(1): 135–154
30. Gonzalez TC, España S, Henkel M et al. (2016) Deliverable 4.4: PMO and SOA Case Validation Report for the CaaS Approach: CaaS - Capability as a Service in digital enterprises, Collaborative Project Number 611351