

# Time Supervision of Concurrent Systems using Symbolic Unfoldings of Time Petri Nets

Thomas Chatain, Claude Jard

► **To cite this version:**

Thomas Chatain, Claude Jard. Time Supervision of Concurrent Systems using Symbolic Unfoldings of Time Petri Nets. [Research Report] PI 1740, 2005. inria-00000342

**HAL Id: inria-00000342**

**<https://hal.inria.fr/inria-00000342>**

Submitted on 26 Sep 2005

**HAL** is a multi-disciplinary open access archive for the deposit and dissemination of scientific research documents, whether they are published or not. The documents may come from teaching and research institutions in France or abroad, or from public or private research centers.

L'archive ouverte pluridisciplinaire **HAL**, est destinée au dépôt et à la diffusion de documents scientifiques de niveau recherche, publiés ou non, émanant des établissements d'enseignement et de recherche français ou étrangers, des laboratoires publics ou privés.

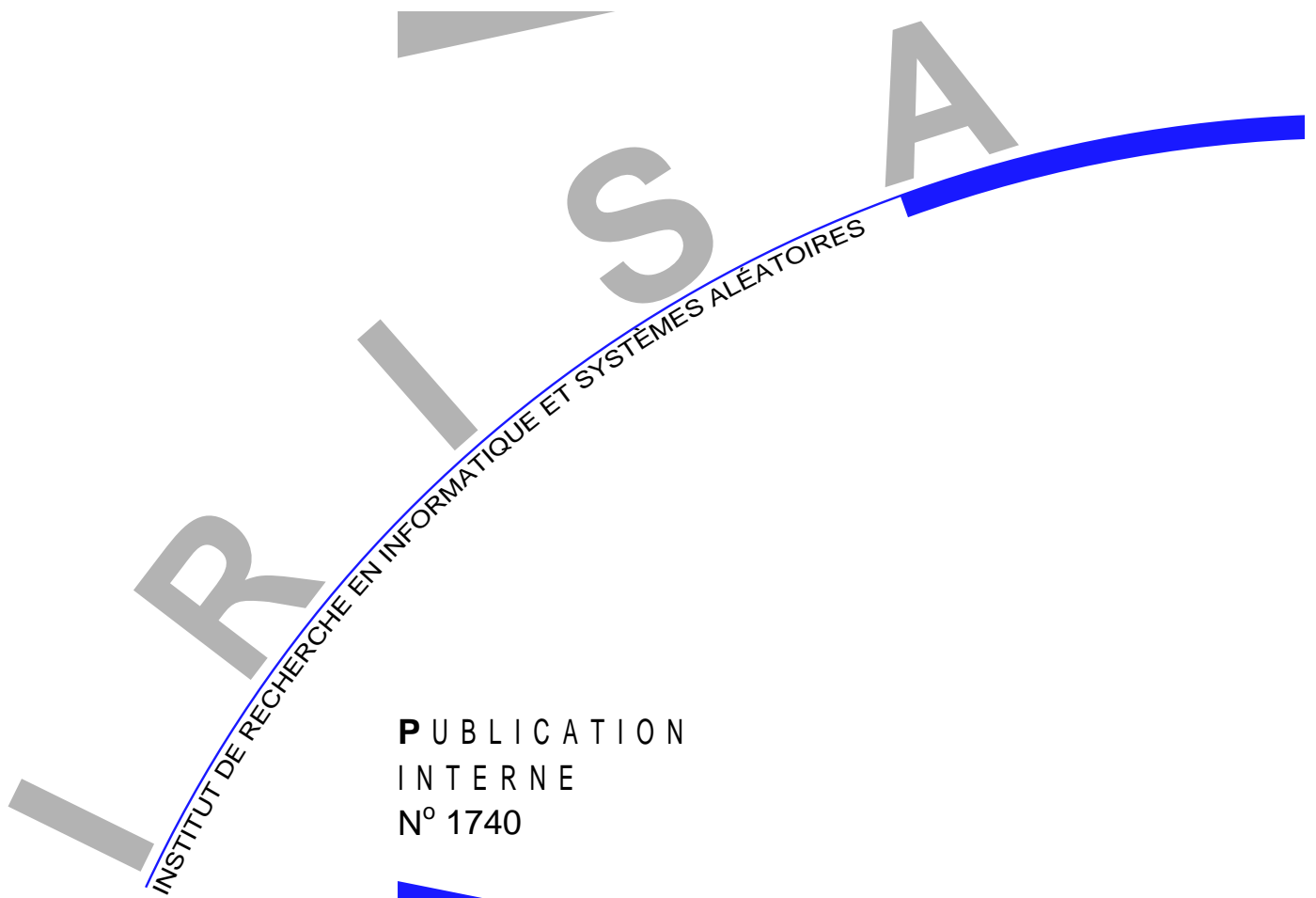

**P**UBLICATION  
INTERNE  
N° 1740

TIME SUPERVISION OF CONCURRENT SYSTEMS  
USING SYMBOLIC UNFOLDINGS OF TIME PETRI NETS

THOMAS CHATAIN , CLAUDE JARD



## Time Supervision of Concurrent Systems using Symbolic Unfoldings of Time Petri Nets

Thomas Chatain<sup>\*</sup>, Claude Jard<sup>\*\*</sup>

Systèmes communicants  
Projet Distribcom

Publication interne n° 1740 — Septembre 2005 — 20 pages

**Abstract:** Monitoring real-time concurrent systems is a challenging task. In this paper we formulate (model-based) supervision by means of hidden state history reconstruction, from event (e.g. alarm) observations. We follow a so-called true concurrency approach using time Petri nets: the model defines explicitly the causality and concurrency relations between the observable events, produced by the system under supervision on different points of observation, and constrained by time aspects. The problem is to compute on-the-fly the different partial order histories, which are the possible explanations of the observable events. We do not impose that time is observable: the aim of supervision is to infer the partial ordering of the events and their possible firing dates. This is achieved by considering a model of the system under supervision, given as a time Petri net, and the on-the-fly construction of an unfolding, guided by the observations. Using a symbolic representation, this paper presents a new definition of the unfolding of time Petri nets with dense time.

**Key-words:** concurrent systems, diagnosis, time Petri nets, unfolding

*(Résumé : tsvp)*

This work was supported by the french RNRT projects Swan and Persiform, funded by the Ministère de la Recherche; partners of the Swan project are Inria, France Telecom R&D, Alcatel, QosMetrics, and University of Bordeaux; partners of the Persiform project are Inria, France Telecom R&D, INT, Orpheus, and University of Grenoble.

<sup>\*</sup> IRISA/ENS Cachan-Bretagne, Campus de Beaulieu, F-35042 Rennes cedex, France,  
[Thomas.Chatain@irisa.fr](mailto:Thomas.Chatain@irisa.fr)

<sup>\*\*</sup> IRISA/ENS Cachan-Bretagne, Campus de Beaulieu, F-35042 Rennes cedex, France,  
[Claude.Jard@bretagne.ens-cachan.fr](mailto:Claude.Jard@bretagne.ens-cachan.fr)



## Supervision des systèmes distribués temporisés basée sur les dépliages symboliques de réseaux de Petri temporels

**Résumé :** La supervision des systèmes distribués temps réel est une problématique d'actualité. Dans ce papier nous abordons la supervision sous forme de reconstruction d'histoires à partir d'observations d'événements (par exemple d'alarmes). Nous proposons une approche de vraie concurrence utilisant les réseaux de Petri temporels : le modèle définit explicitement les relations de causalité et de concurrence entre les événements observables émis par le système qui est observé par plusieurs capteurs et qui est contraint par des aspects temporels. Le problème consiste à calculer au vol les différentes histoires (sous forme d'ordre partiel) qui peuvent expliquer les événements observés. Nous n'imposons pas que le temps soit observable : le but de la supervision est d'inférer l'ordre partiel des événements et les dates de tir possibles. Pour cela nous considérons un modèle du système à superviser, donné sous la forme d'un réseau de Petri temporel, et nous construisons au vol un dépliage guidé par les observations. Cet article présente une nouvelle définition du dépliage d'un réseau de Petri temporel, dans lequel le temps est représenté de manière symbolique.

**Mots clés :** systèmes répartis, diagnostic, réseaux de Petri temporels, dépliage

## 1 Introduction and related work

Monitoring real-time concurrent systems is a challenging task. In this paper we formulate model-based supervision by means of hidden state history reconstruction, from event (e.g. alarm) observations. We follow a so-called true concurrency approach using time Petri nets: the model defines explicitly the causality and concurrency relations between the observable events, produced by the system under supervision on different points of observation, and constrained by time aspects. The problem is to compute on-the-fly the different partial order histories, which are the possible explanations of the observable events. An important application is the supervision of telecommunications networks, which motivated this work.

Without considering time, a natural candidate to formalize the problem are safe Petri nets with branching processes and unfoldings. The previous work of our group used this framework to define the histories and a distributed algorithm to build them as a collection of consistent local views [3]. The approach defines the possible explanations as the underlying event structure of the unfolding of the product of the Petri net model and of an acyclic Petri net representing the partial order of the observed alarms.

In this paper we extend our method to time Petri nets, allowing the designer to model time constraints, restricting by this way the set of possible explanations. We do not impose that time is observable: the aim of supervision is to infer the partial ordering of the events and their possible firing dates. Using a symbolic representation, this paper presents a new definition of the unfolding of time Petri nets with dense time.

Model-based diagnosis using time Petri nets and partial orders has already been addressed in [12]. In this work, temporal reasoning is based on (linear) logic. The first reference to time Petri net unfolding seems to be in 1996, by A. Semenov, A. Yakovlev and A. Koelmans [13] in the context of hardware verification. They deal only with a quite restricted class of nets, called *time independent choice time Petri net*, in which any choice is resolved independently of time. In [1], T. Aura and J. Lilius give a partial order semantics to time Petri nets, based on the nonsequential processes semantics for untimed net systems. A time process of a time Petri net is defined as a traditionally constructed causal process that has a valid timing. An algorithm for checking validity of a given timing is presented. It is proved that the interleavings of the time processes are in bijection with the firing schedules. But unfortunately, they do not provide a way to represent all the valid processes using the notion of unfolding of time Petri net, as usual in the untimed case. A few years later (in 2002), H. Fleischhack and C. Stehno in [10] give the first notion of a finite prefix of the unfolding of a time Petri net. Their method relies on a translation towards an ordinary place/transition net. This requires to consider only discrete time and to enumerate all the situations. This also relies on the introduction of new transitions, which represent the clock ticks. Although relevant for model-checking, it is not clear that it allows us to recover causalities and concurrencies, as required in the diagnosis application. Furthermore, we are convinced that time constraints must be treated in a symbolic way, using the analog of state class constructions of B. Berthomieu [4,5].

The rest of the paper is organized as follows. Section 2 defines the different ingredients of our model-based supervision, namely the diagnosis setup, the time Petri net model and

its partial order semantics. Section 3 describes the symbolic unfolding technique used to compute the symbolic processes, which serve as explanations. Before entering the general case, we consider the simplest case of extended free-choice time Petri nets [6]. We conclude in Section 4.

## 2 Diagnosis, time Petri nets and partial order semantics

### 2.1 Diagnosis: problem

Let us consider a real distributed system, which produces on a given set of sensors some events (or alarms) during its life. We consider the following setup for diagnosis, assuming that alarms are not lost. Each sensor records its local alarms in sequence, while respecting causality (i.e. the observed sequences cannot contradict the causal and temporal ordering defined in the model). The different sensors perform independently and asynchronously, and a single supervisor collects the records from the different sensors. Thus any interleaving of the records from different sensors is possible, and causalities and temporal ordering among alarms from different sensors are lost. This architecture is illustrated in Figure 1.

For the development of the example, we consider that the system under supervision produces the sequences  $\alpha\gamma\alpha\gamma$  on sensor A, and  $\beta\beta$  on sensor B. Given the time Petri net model of Figure 1 (left), the goal of the diagnoser is to compute all the possible explanations shown in Figure 1. Explanations are labelled partial orders. Each node is labeled by a transition of the Petri net model and a possible date given by a symbolic expression. Notice that the diagnoser infers the possible causalities between alarms, as well as the possible dates for each of them. The first alarms  $\alpha\gamma\alpha$  and  $\beta\beta$  imply that transitions  $t_1$  and  $t_2$  are fired twice and concurrently. The last  $\gamma$  can be explained by two different transitions in conflict ( $t_3$  and  $t_4$ ).

### 2.2 Time Petri net: definition

**Notations.** We denote  $f^{-1}$  the inverse of a bijection  $f$ . We denote  $f|_A$  the restriction of a mapping  $f$  to a set  $A$ . The restriction has higher priority than the inverse:  $f|_A^{-1} = (f|_A)^{-1}$ . We denote  $\circ$  the usual composition of functions.  $Q$  denotes the set of nonnegative rational numbers.

Time Petri nets were introduced in [11].

A *time Petri net* (TPN) is a tuple  $N = \langle P, T, pre, post, efd, lfd \rangle$  where  $P$  and  $T$  are finite sets of *places* and *transitions* respectively,  $pre$  and  $post$  map each transition  $t \in T$  to its *preset* often denoted  $\bullet t \stackrel{\text{def}}{=} pre(t) \subseteq P$  ( $\bullet t \neq \emptyset$ ) and its *postset* often denoted  $t \bullet \stackrel{\text{def}}{=} post(t) \subseteq P$ ;  $efd : T \rightarrow Q$  and  $lfd : T \rightarrow Q \cup \{\infty\}$  associate the *earliest firing delay*  $efd(t)$  and *latest firing delay*  $lfd(t)$  with each transition  $t$ . A TPN is represented as a graph with two types of nodes: places (circles) and transitions (bars). The closed interval  $[efd(t), lfd(t)]$  is written near each transition. For the purpose of supervision, we consider *labelled time Petri nets*

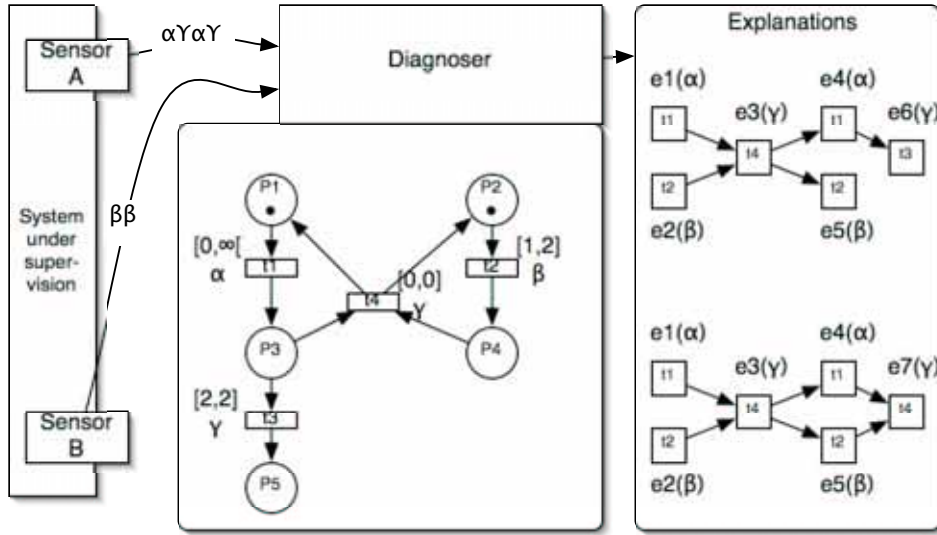

Fig. 1. Model-based diagnosis of distributed systems using time Petri nets.

$\langle N, A, \lambda \rangle$  where  $A$  is a set of event types (or alarms), and  $\lambda$  the typing of transitions ( $\alpha, \beta, \gamma$  in Figure 1).

A state of a time Petri net is given by a triple  $\langle M, dob, \theta \rangle$ , where  $M \subseteq P$  is a marking denoted with tokens (thick dots),  $\theta \in Q$  is its date and  $dob : M \rightarrow Q$  associates a date of birth  $dob(p) \leq \theta$  with each token (marked place)  $p \in M$ . A transition  $t \in T$  is enabled in the state  $\langle M, dob, \theta \rangle$  if all of its input places are marked:  $\bullet t \subseteq M$ . Its date of enabling  $doe(t)$  is the date of birth of the youngest token in its input places:  $doe(t) \stackrel{\text{def}}{=} \max_{p \in \bullet t} dob(p)$ . All the time Petri nets we consider in this article are *safe*, i.e. in each reachable state  $\langle M, dob, \theta \rangle$ , if a transition  $t$  is enabled in  $\langle M, dob, \theta \rangle$ , then  $t \bullet \cap (M \setminus \bullet t) = \emptyset$ .

A process of a TPN starts in an *initial state*  $\langle M_0, dob_0, \theta_0 \rangle$ , which is given by the *initial marking*  $M_0$  and the initial date  $\theta_0$ . Initially, all the tokens carry the date  $\theta_0$  as date of birth:  $\forall p \in M_0 \quad dob_0(p) \stackrel{\text{def}}{=} \theta_0$ .

The transition  $t$  can fire at date  $\theta' \geq \theta$  from state  $\langle M, dob, \theta \rangle$ , if:

- $t$  is enabled:  $\bullet t \subseteq M$ ;
- the minimum delay is reached:  $\theta' \geq doe(t) + efd(t)$ ;
- the enabled transitions do not overtake the maximum delays:  
 $\forall t' \in T \quad \bullet t' \subseteq M \implies \theta' \leq doe(t') + lfd(t')$ .

The firing of  $t$  at date  $\theta'$  leads to the state  $\langle (M \setminus \bullet t) \cup t \bullet, dob', \theta' \rangle$ , where  $dob'(p) \stackrel{\text{def}}{=} dob(p)$  if  $p \in M \setminus \bullet t$  and  $dob'(p) \stackrel{\text{def}}{=} \theta'$  if  $p \in t \bullet$ .



Finally we assume that time *diverges*: when infinitely many transitions fire, time necessarily diverges to infinity.

In the initial state of the net of Figure 1,  $p_1$  and  $p_2$  are marked and their date of birth is 0.  $t_1$  and  $t_2$  are enabled and their date of enabling is the initial date 0.  $t_2$  can fire in the initial state at any time between 1 and 2. Choose time 1. After this firing  $p_1$  and  $p_4$  are marked,  $t_1$  is the only enabled transition and it has already waited 1 time unit.  $t_1$  can fire at any time  $\theta$ , provided it is greater than 1. Consider  $t_1$  fires at time 3.  $p_3$  and  $p_4$  are marked in the new state, and transitions  $t_3$  and  $t_4$  are enabled, and their date of enabling is 3 because they have just been enabled by the firing of  $t_1$ . To fire,  $t_3$  would have to wait 2 time units. But transition  $t_4$  cannot wait at all. So  $t_4$  will necessarily fire (at time 3), and  $t_3$  cannot fire.

*Remark.* The semantics of time Petri nets are often defined in a slightly different way: the state of the net is given as a pair  $\langle M, I \rangle$ , where  $M$  is the marking, and  $I$  maps each enabled transition  $t$  to the delay that has elapsed since it was enabled, that is  $\theta - \text{doe}(t)$  with our notations. It is more convenient for us to attach time information on the tokens of the marking than on the enabled transitions. We have chosen the date of birth of the tokens rather than their age, because we want to make the impact of the firing of transitions as local as possible. And the age of each token in the marking must be updated each time a transition  $t$  fires, whereas the date of birth has to be set only for the tokens that are created by  $t$ . Furthermore, usual semantics often deal with the delay between the firing of two consecutive transitions. In this paper we use the absolute firing date of the transitions instead. This fits better to our approach in which we are not interested in the total ordering of the events.

### 2.3 Partial order semantics

**Processes.** We will define the set  $X$  of (finite) processes of a safe time Petri net starting at date  $\theta_0$  in the initial marking  $M_0$ . These processes are those described in [1]. We define them inductively and use a canonical coding like in [8]. The processes provide a partial order representation of the executions.

Each process will be a pair  $x \stackrel{\text{def}}{=} \langle E, \Theta \rangle$ , where  $E$  is a set of *events*, and  $\Theta : E \rightarrow Q$  maps each event to its firing date.  $\Theta$  is sometimes represented as a set of pairs  $(e, \Theta(e))$ . Each event  $e$  is a pair  $(\bullet e, \tau(e))$  that codes an occurrence of the transition  $\tau(e)$  in the process.  $\bullet e$  is a set of pairs  $b \stackrel{\text{def}}{=} (\bullet b, \text{place}(b)) \in E \times P$ . Such a pair is called a *condition* and refers to the token that has been created by the event  $\bullet b$  in the place  $\text{place}(b)$ . We say that the event  $e \stackrel{\text{def}}{=} (\bullet e, \tau(e))$  *consumes* the conditions in  $\bullet e$ . Symmetrically the set  $\{(e, p) \mid p \in \tau(e)\bullet\}$  of conditions that are *created* by  $e$  is denoted  $e\bullet$ .

For all set  $B$  of conditions, we denote  $\text{Place}(B) \stackrel{\text{def}}{=} \{\text{place}(b) \mid b \in B\}$ , and when the restriction of  $\text{place}$  to  $B$  is injective, we denote  $\text{place}_{|B}^{-1}$  its inverse, and for all  $P \subseteq \text{Place}(B)$ ,  $\text{Place}_{|B}^{-1}(P) \stackrel{\text{def}}{=} \{\text{place}_{|B}^{-1}(p) \mid p \in P\}$ .

The set of conditions that remain at the end of the process  $\langle E, \Theta \rangle$  (meaning that they have been created by an event of  $E$ , and no event of  $E$  has consumed them) is

$\uparrow(E) \stackrel{\text{def}}{=} \bigcup_{e \in E} e^\bullet \setminus \bigcup_{e \in E} \bullet e$  (it does not depend on  $\Theta$ ). The state that is reached after the process  $\langle E, \Theta \rangle$  is  $\langle \text{Place}(\uparrow(E)), \text{dob}, \max_{e \in E} \Theta(e) \rangle$ , where for all  $p \in \text{Place}(\uparrow(E))$ ,  $\text{dob}(p) \stackrel{\text{def}}{=} \Theta(\bullet b)$ , with  $b \stackrel{\text{def}}{=} \text{place}_{\uparrow(E)}^{-1}(p)$ .

We define inductively the set  $X$  of (finite) processes of a time Petri net starting at date  $\theta_0$  in the initial marking  $M_0$  as follows:

- $\langle \{\perp\}, \{(\perp, \theta_0)\} \rangle \in X$ , where  $\perp \stackrel{\text{def}}{=} (\emptyset, \epsilon)$  represents the initial event. Notice that the initial event does not actually represent the firing of a transition, which explains the use of the special value  $\epsilon \notin T$ . For the same reason, the set of conditions that are created by  $\perp$  is defined in a special way:  $\perp^\bullet \stackrel{\text{def}}{=} \{(\perp, p) \mid p \in M_0\}$ .
- For all process  $\langle E, \Theta \rangle \in X$  leading to state  $\langle M, \text{dob}, \theta \rangle$ , if a transition  $t$  can fire at date  $\theta' \geq \theta$  from state  $\langle M, \text{dob}, \theta \rangle$ , then  $\langle E \cup \{e\}, \Theta \cup \{(e, \theta')\} \rangle \in X$ , where the event  $e \stackrel{\text{def}}{=} (\text{Place}_{\uparrow(E)}^{-1}(\bullet t), t)$  represents this firing of  $t$ .

We define the relation  $\rightarrow$  on the events as:  $e \rightarrow e'$  iff  $e^\bullet \cap \bullet e' \neq \emptyset$ . The reflexive transitive closure  $\rightarrow^*$  of  $\rightarrow$  is called the *causality* relation. For all event  $e$ , we denote  $[e] \stackrel{\text{def}}{=} \{f \in E \mid f \rightarrow^* e\}$ , and for all set  $E$  of events,  $[E] \stackrel{\text{def}}{=} \bigcup_{e \in E} [e]$ . We also define  $\text{cnds}(E) \stackrel{\text{def}}{=} \bigcup_{e \in E} e^\bullet$  the set of *conditions* created by the events of  $E$ .

Two events of a process that are not causally related are said to be *concurrent*.

**Symbolic processes.** We choose to group the processes that differ only by their firing dates to obtain what we call a *symbolic process*.

A symbolic process of a time Petri net is a pair  $\langle E, \text{pred} \rangle$  with  $\text{pred} : (E \rightarrow Q) \rightarrow \mathbf{bool}$ , such that for all mapping  $\Theta : E \rightarrow Q$ , if  $\text{pred}(\Theta)$ , then  $\langle E, \Theta \rangle \in X$ .

In practice,  $\text{pred}$  is described by linear inequalities. Examples of symbolic processes are given in Figure 1. The first explanation groups all the processes formally defined as  $\langle E, \Theta \rangle$  where  $E$  contains the six following events, with the associated firing dates (the initial event  $\perp$  is not represented):

$$\begin{array}{ll}
 1 = (\{\perp, P_1\}, t_1) & \Theta(1) \geq \Theta(\perp) \\
 2 = (\{\perp, P_2\}, t_2) & 1 \leq \Theta(2) - \Theta(\perp) \leq 2 \\
 3 = (\{1, P_3\}, \{2, P_4\}, t_4) & \Theta(3) = \max\{\Theta(1), \Theta(2)\} \\
 4 = (\{3, P_1\}, t_1) & \Theta(4) = \Theta(3) \\
 5 = (\{3, P_2\}, t_2) & \Theta(5) = \Theta(3) + 2 \\
 6 = (\{4, P_3\}, t_3) & \Theta(6) = \Theta(4) + 2
 \end{array}$$

## 2.4 Diagnosis: formal problem setting

Consider a net  $N$  modeling a system and an observation  $O$  of this system, which associates a finite sequence of observed alarms  $(\lambda_{s,1}, \dots, \lambda_{s,n_s})$  with each sensor  $s$ . The set of sensors is denoted  $S$ . For each sensor  $s$ ,  $A_s$  indicates which alarms the sensor observes.

To compute a diagnosis, we propose to build a net  $\mathcal{D}(N, O)$  whose processes correspond to the processes of  $N$  which satisfy the observation  $O$ . The idea is to constrain the model by

adding new places and transitions so that each transition of the model that sends an alarm to a sensor  $s$  is not allowed to fire until all the previous alarms sent to  $s$  have been observed.

To achieve this we create a place  $s_\lambda$  for each alarm  $\lambda$  that may be sent to the sensor  $s$ , plus one place  $\bar{s}$ . For each transition  $t$  that sends an alarm  $\lambda$  to the sensor  $s$ , we add  $s_\lambda$  to the postset of  $t$ . After the  $i^{\text{th}}$  alarm is sent to  $s$ , a new transition  $t_{s,i}$  which models the observation of this alarm by  $s$ , removes the token from  $s_\lambda$  and creates a token in the place  $\bar{s}$ , meaning that the alarm has been observed.  $\bar{s}$  is added to the preset of each transition that sends an alarm to  $s$ , so that it cannot fire before the previous alarm has been observed. The transitions  $t_{s,i}$  are connected through places  $p_{s,i}$  so that they must fire one after another.

Formally, for a net  $N \stackrel{\text{def}}{=} \langle P, T, pre, post, efd, lfd \rangle$  and an observation  $O$  from a set  $S$  of sensors, we define a net  $\mathcal{D}(N, O) \stackrel{\text{def}}{=} \langle P', T', wpre', pre', post', efd', lfd' \rangle$ . This net is almost a time Petri net: a *weak preset*  $wpre'(t) \subseteq pre'(t)$ , denoted  ${}^\circ t$  has been added for each transition  $t \in T'$ ; only the date of birth of the tokens in the weak preset participate in the definition of the *date of weak enabling* of  $t$ , which replaces the date of enabling in the semantics:  $dowe(t) \stackrel{\text{def}}{=} \max_{p \in {}^\circ t} dob(p)$ . In the processes, for each event  $e$ , we denote  ${}^\circ e \stackrel{\text{def}}{=} Place_{\bullet}^{-1}({}^\circ \tau(e))$ . Notice that the net may reach a degenerated state  $\langle M, dob, \theta \rangle$  where a weakly enabled transition  $t$  has overtaken its maximum firing date ( $\theta > dowe(t) + lfd(t)$ ). In  $\mathcal{D}(N, O)$  this situation does not occur in the processes that generate explanations.

$\mathcal{D}(N, O)$  is defined as follows (where  $\uplus$  denotes the disjoint union):

- $P' \stackrel{\text{def}}{=} P \uplus \{\bar{s} \mid s \in S\} \uplus \{s_\lambda \mid s \in S \wedge \lambda \in A_s\} \uplus \{p_{s,i} \mid s \in S, i = 0, \dots, n_s\}$ ;
- $T' \stackrel{\text{def}}{=} T \uplus \{t_{s,i} \mid s \in S, i = 1, \dots, n_s\}$ ;
- for all  $t \in T$ ,  $wpre'(t) \stackrel{\text{def}}{=} pre(t)$ ,  $pre'(t) \stackrel{\text{def}}{=} wpre'(t) \uplus \{\bar{s} \mid \lambda(t) \in A_s\}$ ,  
 $post'(t) \stackrel{\text{def}}{=} post(t) \uplus \{s_{\lambda(t)} \mid \lambda(t) \in A_s\}$ ,  
 $efd'(t) \stackrel{\text{def}}{=} efd(t)$  and  $lfd'(t) \stackrel{\text{def}}{=} lfd(t)$ ;
- $wpre'(t_{s,i}) = pre'(t_{s,i}) \stackrel{\text{def}}{=} \{p_{s,i-1}, s_{\lambda_{s,i}}\}$ ,  $post'(t_{s,i}) \stackrel{\text{def}}{=} \{p_{s,i}, \bar{s}\}$  and  
 $efd'(t_{s,i}) = lfd'(t_{s,i}) \stackrel{\text{def}}{=} 0$ .

Figure 2 shows the net of Figure 1 constrained by the observation  $\alpha\gamma\alpha\gamma$  from sensor A and  $\beta\beta$  from sensor B.

We call *diagnosis of observation  $O$  on net  $N$*  any set of symbolic processes of  $\mathcal{D}(N, O)$ , which contain all the processes  $\langle E, \Theta \rangle$  of  $\mathcal{D}(N, O)$  such that:  $\{p_{s,n_s} \mid s \in S\} \uplus \{\bar{s}_\lambda \mid s \in S \wedge \lambda \in A_s\} \subseteq Place(\uparrow(E))$ . Unless the model contains loops of non observable events, these processes can be described by a finite set of symbolic processes. These processes can be projected to keep only the conditions and events which correspond to places and transitions of the model. Then we obtain all the processes of  $N$  that are compatible with the observation  $O$ , as shown in Figure 1. The construction of the explanations is based on the unfolding of  $\mathcal{D}(N, O)$ . The notion of unfolding allows us to use a compact representation of the processes by sharing the common prefixes. The temporal framework leads naturally to consider the new notion of symbolic unfolding that we detail in the following section.

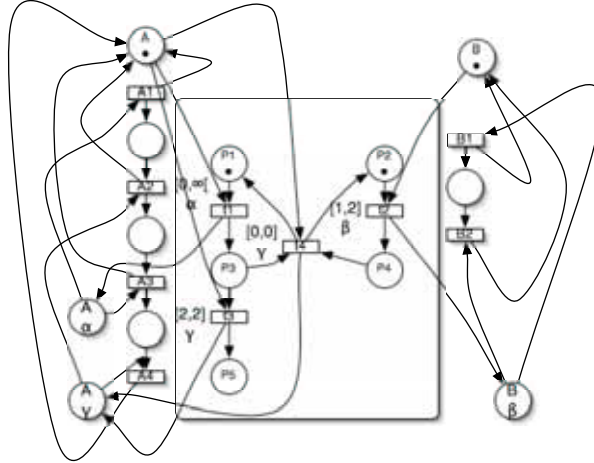

Fig. 2. Our example of TPN, constrained by the observation  $\alpha\gamma\alpha\gamma$  from sensor A and  $\beta\beta$  from sensor B.

### 3 Symbolic unfoldings of time Petri nets

Symbolic unfoldings have already been addressed in the context of high-level Petri nets [7]. In this section we define the symbolic unfolding of time Petri nets, i.e. a quite compact structure that contains all the possible processes and exhibits concurrency. Actually the time Petri nets are extended with weak presets<sup>1</sup>, as required by our diagnosis approach (see Section 2.4).

For symbolic unfoldings of classical time Petri nets, consider that the weak preset  ${}^{\circ}t$  of any transition  $t \in T$  is equal to its preset  $\bullet t$ .

#### 3.1 Pre-processes

For the construction of symbolic unfoldings of time Petri nets, we need the notion of *pre-process*, that extends the notion of process.

For all process  $\langle E, \Theta \rangle$ , and for all nonempty, causally closed set of events  $E' \subseteq E$  ( $\perp \in E'$  and  $[E'] = E'$ ),  $\langle E', \Theta|_{E'} \rangle$  is called a *pre-process*. We often write  $\langle E', \Theta \rangle$  instead of  $\langle E', \Theta|_{E'} \rangle$  for short. The definition of the state that is reached after a process is also used for pre-processes. We define the *prefix* relation  $\leq$  on pre-processes as follows:

$$\langle E, \Theta \rangle \leq \langle E', \Theta' \rangle \quad \text{iff} \quad E \subseteq E' \wedge \Theta = \Theta'|_E$$

<sup>1</sup> We assume that the net never reaches a degenerated state  $\langle M, \text{dow}, \theta \rangle$  where a weakly enabled transition  $t$  has overtaken its maximum firing date ( $\theta > \text{dow}(t) + \text{lfd}(t)$ ).

### 3.2 Symbolic unfoldings of extended free choice time Petri nets

An *extended free choice* time Petri net is a time Petri net such that:

$$\forall t, t' \in T \quad \bullet t \cap \bullet t' \neq \emptyset \implies \bullet t = \bullet t'.$$

We define the *symbolic unfolding*  $U$  of an extended free choice time Petri net by collecting all the events that appear in its processes:  $U \stackrel{\text{def}}{=} \bigcup_{\langle E, \Theta \rangle \in X} E$ .

This unfolding has two important properties in the case of extended free choice time Petri nets:

**Theorem 1.** *Let  $E \subseteq U$  be a nonempty finite set of events and  $\Theta : E \rightarrow Q$  associate a firing date with each event of  $E$ .  $\langle E, \Theta \rangle$  is a pre-process iff:*

$$\begin{cases} [E] = E & (E \text{ is causally closed}) \\ \nexists e, e' \in E \quad e \neq e' \wedge \bullet e \cap \bullet e' \neq \emptyset & (E \text{ is conflict free}) \\ \forall e \in E \setminus \{\perp\} \quad \text{lpred}(e, \Theta) & (\text{all the events respect the firing delays}) \end{cases}$$

where

$$\text{lpred}(e, \Theta) \stackrel{\text{def}}{=} \begin{cases} \Theta(e) \geq \max_{b \in \bullet e} \Theta(\bullet b) & (t \text{ is strongly enabled when } e \text{ fires}) \\ \Theta(e) \geq \text{dowe}(t) + \text{efd}(t) & (\text{the earliest firing delay is reached}) \\ \forall t' \in T \quad \bullet t' = \bullet t \implies \Theta(e) \leq \text{dowe}(t') + \text{lfd}(t') & (\text{the latest firing delays are respected}) \end{cases}$$

with  $t \stackrel{\text{def}}{=} \tau(e)$  and

for all  $t' \in T$  such that  $\bullet t' = \bullet t$ ,  $\text{dowe}(t') \stackrel{\text{def}}{=} \max_{b \in \text{Place}_{\perp}^{-1}(\bullet t')} \Theta(\bullet b)$ .

**Theorem 2.** *For all  $e \stackrel{\text{def}}{=} (B, t) \in \text{cnds}(U) \times T$ ,*

$$e \in U \text{ iff } \begin{cases} \text{Place}(B) = \bullet t \\ \nexists f, f' \in [e] \quad f \neq f' \wedge \bullet f \cap \bullet f' \neq \emptyset \\ \exists \Theta : [e] \rightarrow Q \quad \forall f \in [e] \setminus \{\perp\} \quad \text{lpred}(f, \Theta) \end{cases}$$

The first theorem gives a way to extract processes from the unfolding, while the second theorem gives a direct construction of the unfolding: adding a new event  $e$  just requires solving linear constraints on the  $\Theta(f)$ ,  $f \in [e]$ . This also happens with symbolic unfoldings of high-level Petri nets introduced in [7].

We do not give proofs for the theorems 1 and 2 as they are particular cases of the theorems 3 and 4: the symbolic unfolding of extended free choice time Petri nets as defined in this section is the same as the symbolic unfolding we obtain if we use the general definition of the next section.

### 3.3 Symbolic unfoldings of time Petri nets: general case

If we define the symbolic unfolding of a time Petri net in the general case as we have done for extended free choice time Petri nets, none of the two previous theorems hold: extracting a process from the unfolding becomes complex (see [1]); and especially we do not know any direct way to build the unfolding. It is also interesting to notice that the union of two pre-processes  $\langle E, \Theta \rangle$  and  $\langle E', \Theta' \rangle$  is not necessarily a pre-process, even if  $\Theta|_{E \cap E'} = \Theta'|_{E \cap E'}$  and  $E \cup E'$  is conflict free. In the example of Figure 1, we observe this if  $\langle E, \Theta \rangle$  is the process which contains a firing of  $t_1$  at time 0 and a firing of  $t_2$  at time 1, and  $\langle E', \Theta' \rangle$  is the pre-process that we obtain by removing the firing of  $t_2$  from the process made of  $t_1$  at time 0,  $t_2$  at time 2 and  $t_3$  at time 2. These difficulties come from the fact that the condition that allows us to extend a process  $x \stackrel{\text{def}}{=} \langle E, \Theta \rangle$  with a new event  $e$  concerns all the state reached after the process  $x$ , and however the conditions in  $\bullet e$  refer only to the tokens in the input places of  $\tau(e)$ .

From now on we assume that we know a partition of the set  $P$  of places of the net in sets  $P_i \subseteq P$  of mutually exclusive places<sup>2</sup>; more precisely we demand that for all reachable marking  $M$ ,  $P_i \cap M$  is a singleton. For all place  $p \in P_i$ , we denote  $\bar{p} \stackrel{\text{def}}{=} P_i \setminus \{p\}$ . In the example of Figure 1, we will use the partition  $\{p_1, p_3, p_5\}, \{p_2, p_4\}$ .

**Notion of partial state.** A *partial state* of a time Petri net is a triple  $\langle L, \text{dob}, \theta \rangle$  with  $L \subseteq P$ ,  $\theta \in Q$  is a date and  $\text{dob} : L \rightarrow Q$  associates a *date of birth*  $\text{dob}(p) \leq \theta$  with each token (marked place)  $p \in L$ .

We define the relation  $\sqsubseteq$  on partial states as follows:

$$\langle L, \text{dob}, \theta \rangle \sqsubseteq \langle L', \text{dob}', \theta' \rangle \text{ iff } L \subseteq L' \wedge \text{dob} = \text{dob}'|_L \wedge \theta \leq \theta'$$

**Firing a transition from a partial state.** Although the semantics of time Petri nets requires to check time conditions for all the enabled transitions in the net, before firing a transition, there are cases when we know that a transition can fire at a given date  $\theta'$ , even if other transitions will fire before  $\theta'$  in other parts of the net. As an example consider the net of Figure 1 starting at date 0 with the marking  $\{p_1, p_2\}$ . Although the semantics forbids to fire  $t_1$  at date 10 before firing  $t_2$ , we feel that nothing can prevent  $t_1$  from firing at date 10, because only  $t_1$  can remove the token in place  $p_1$ . By contrast, the firing of  $t_3$  highly depends on the firing date of  $t_2$  because when  $t_4$  is enabled it fires immediately and disables  $t_3$ . So if we want to fire  $t_3$  we have to check whether  $p_2$  or  $p_4$  is marked.

A *partial state firing* is a triple  $(S, t, \theta')$  where  $S \stackrel{\text{def}}{=} \langle L, \text{dob}_L, \theta_L \rangle$  is a partial state,  $t$  is a transition such that  $\bullet t \subseteq L$ , and  $\theta' \geq \theta_L$  is a date.

<sup>2</sup> If we do not know any such partition, a solution is to extend the structure of the net with one complementary place for each place of the net and to add these new places in the preset (but not in the weak preset) and in the postset of the transitions such that in any reachable marking each place  $p \in P$  is marked iff its complementary place is not. This operation does not change the behaviour of the time Petri net: since the weak presets do not change, the tokens in the complementary places do not participate in the definition of the date of enabling.

The idea in partial state firings is that the partial state  $S$  gives enough information to be sure that  $t$  can fire at date  $\theta'$ .

It will be crucial in the following to know how to select partial state firings. However several choices are possible. If we are given a predicate  $PSF$  on partial state firings, we can build extended processes by using only the extended processes that satisfy  $PSF$ . Then we will try to map these extended processes into pre-processes. If  $PSF$  is valid, then all the pre-processes we obtain are correct.

**Extended processes.** Let  $PSF$  be a predicate on partial state firings.

We will define a notion of *extended process* (parameterized by  $PSF$ ), which is close to the notion of process, but the events are replaced by *extended events* which represent firings from partial states and keep track of all the conditions corresponding to the partial state, not only those that are consumed by the transition: the other conditions will be treated as context of the event. This uses classical techniques of *contextual nets* or nets with *read arcs* (see [2,14]). It would also be possible to consume and rewrite the conditions in the context of an event, but we feel that the notion of read arc or contextual is a good way to capture the idea that we develop here.

For all extended event  $\dot{e} \stackrel{\text{def}}{=} (B, t)$ , use the notations  $\tau(\dot{e}) \stackrel{\text{def}}{=} t$ ,  $\bullet\dot{e} \stackrel{\text{def}}{=} \text{Place}_{|B}^{-1}(\bullet t)$ ,  $\circ\dot{e} \stackrel{\text{def}}{=} \text{Place}_{|B}^{-1}(\circ t)$ ,  $\dot{e} \stackrel{\text{def}}{=} B \setminus \bullet\dot{e}$  and  $\dot{e}\bullet \stackrel{\text{def}}{=} \{(e, p) \mid p \in t\bullet\}$ . We define the relations  $\rightarrow$  and  $\nearrow$  between extended events as:

- $\dot{e} \rightarrow \dot{f}$  iff  $\dot{e}\bullet \cap (\bullet\dot{f} \cup \dot{f}) \neq \emptyset$  and
- $\dot{e} \nearrow \dot{f}$  iff  $(\dot{e} \rightarrow \dot{f}) \vee (\dot{e} \cap \bullet\dot{f} \neq \emptyset)$ .

Like for processes, we define the set of conditions that remain at the end of the extended process  $\langle \dot{E}, \Theta \rangle$  as  $\uparrow(\dot{E}) \stackrel{\text{def}}{=} \bigcup_{\dot{e} \in \dot{E}} \dot{e}\bullet \setminus \bigcup_{\dot{e} \in \dot{E}} \bullet\dot{e}$ . But for extended processes we define not only the global state that is reached after  $\langle \dot{E}, \Theta \rangle$ , but a partial state  $RS_{\Theta}(B)$  associated with each set of conditions  $B \subseteq \uparrow(\dot{E})$ . The partial state associated with  $B$  does not depend on the set of events  $\dot{E}$  provided  $\bigcup_{b \in B} \bullet b \subseteq \dot{E}$ . It is defined as  $RS_{\Theta}(B) \stackrel{\text{def}}{=} \langle \text{Place}(B), \text{dob}_L, \theta_L \rangle$ , where  $\text{dob}_L(p) \stackrel{\text{def}}{=} \Theta(\bullet(\text{place}_{|B}^{-1}(p)))$  and  $\theta_L \stackrel{\text{def}}{=} \max_{b \in B} \Theta(\bullet b)$ .

We define the set  $\dot{X}_{PSF}$  of *extended processes* of a time Petri net starting at date  $\theta_0$  in the initial marking  $M_0$  as follows.

- Like for processes,  $\langle \{\perp\}, \{(\perp, \theta_0)\} \rangle \in \dot{X}_{PSF}$ , where  $\perp \stackrel{\text{def}}{=} (\emptyset, \epsilon)$  represents the initial event. The set of conditions that are created by  $\perp$  is defined as:  $\perp\bullet \stackrel{\text{def}}{=} \{(\perp, p) \mid p \in M_0\}$ .
- For all extended process  $\langle \dot{E}, \Theta \rangle \in \dot{X}_{PSF}$ , for all  $\dot{e} \stackrel{\text{def}}{=} (B, t)$  with  $B \subseteq \uparrow(\dot{E})$ , and  $t \in T$ , for all  $\theta' \geq \max_{j \in \dot{E}, j \nearrow \dot{e}} \Theta(j)$ , if  $PSF(RS_{\Theta}(B), t, \theta')$  holds, then  $\langle \dot{E} \cup \{\dot{e}\}, \Theta \cup \{(\dot{e}, \theta')\} \rangle \in \dot{X}_{PSF}$ .

Each extended event  $\dot{e}$  can be mapped to the corresponding event

$$h(\dot{e}) \stackrel{\text{def}}{=} \left( \{(h(\dot{f}), p) \mid (\dot{f}, p) \in \bullet\dot{e}\}, \tau(\dot{e}) \right).$$

**Corectness of PSF.** We say that *PSF* is a *valid predicate on partial state firings* iff for all extended process  $\langle \dot{E}, \Theta \rangle \in \dot{X}_{PSF}$ ,  $\langle h(\dot{E}), \Theta \circ h|_{\dot{E}}^{-1} \rangle$  is a pre-process (notice that  $h|_{\dot{E}}$  is injective). In other terms there exists a process  $\langle E', \Theta' \rangle \in X$  such that  $\langle h(\dot{E}), \Theta \circ h|_{\dot{E}}^{-1} \rangle \leq \langle E', \Theta' \rangle$ .

**Symbolic unfolding.** As we did for extended free choice time Petri nets with events in Section 3.2, we define the *symbolic unfolding*  $U_{PSF}$  of a time Petri net by collecting all the extended events that appear in its extended processes:  $U_{PSF} \stackrel{\text{def}}{=} \bigcup_{\langle \dot{E}, \Theta \rangle \in \dot{X}_{PSF}} \dot{E}$ .

We have equivalents of the two theorems we had with symbolic unfoldings of extended free choice time Petri nets.

**Theorem 3.** *Let  $\dot{E} \subseteq U_{PSF}$  be a nonempty finite set of extended events and  $\Theta : \dot{E} \rightarrow Q$  associate a firing date with each extended event of  $\dot{E}$ .  $\langle \dot{E}, \Theta \rangle$  is an extended process iff:*

$$\left\{ \begin{array}{l} [\dot{E}] = \dot{E} \quad (\dot{E} \text{ is causally closed}) \\ \nexists \dot{e}, \dot{e}' \in \dot{E} \quad \dot{e} \neq \dot{e}' \wedge \bullet \dot{e} \cap \bullet \dot{e}' \neq \emptyset \quad (\dot{E} \text{ is conflict free}) \\ \nexists \dot{e}_0, \dot{e}_1, \dots, \dot{e}_n \in \dot{E} \quad \dot{e}_0 \nearrow \dot{e}_1 \nearrow \dots \nearrow \dot{e}_n \nearrow \dot{e}_0 \quad (\nearrow \text{ is acyclic on } \dot{E}) \\ \forall \dot{e}, \dot{e}' \in \dot{E} \quad \dot{e} \nearrow \dot{e}' \implies \Theta(\dot{e}) \leq \Theta(\dot{e}') \quad (\Theta \text{ is compatible with } \nearrow) \\ \forall \dot{e} \in \dot{E} \setminus \{\perp\} \quad PSF(RS_{\Theta}(\bullet \dot{e} \cup \underline{\dot{e}}), \tau(\dot{e}), \Theta(\dot{e})) \quad (\dot{e} \text{ corresponds to a partial state firing}) \end{array} \right.$$

*Proof.* Let  $\langle \dot{E}, \Theta \rangle \in \dot{X}_{PSF}$  be an extended process that satisfies the conditions in the curly brace, let  $\dot{e} \stackrel{\text{def}}{=} (B, t)$  with  $B \subseteq \uparrow(\dot{E})$  and  $t \in T$  and  $\theta' \geq \max_{f \in \dot{E}, f \nearrow \dot{e}} \Theta(f)$  such that  $PSF(RS_{\Theta}(B), t, \theta')$  holds. Then we will show that the extended process  $\langle \dot{E}', \Theta' \rangle \stackrel{\text{def}}{=} \langle \dot{E} \cup \{\dot{e}\}, \Theta \cup \{(\dot{e}, \theta')\}$  also satisfies the conditions in the curly brace. By construction  $\dot{E}'$  is causally closed. Moreover for each condition  $b \in \bullet \dot{e}$  that is consumed by  $\dot{e}$ ,  $b \in \uparrow(\dot{E})$ , which implies that  $b$  has not been consumed by any event of  $\dot{E}$ . Thus for all  $f \in \dot{E}$ ,  $\bullet \dot{e} \cap \bullet f = \emptyset$  and  $\neg(\dot{e} \nearrow f)$ . So  $\dot{E}'$  is conflict free and  $\nearrow$  is acyclic on  $\dot{E}'$ .  $\Theta'$  is compatible with  $\nearrow$  because  $\Theta$  is compatible with  $\nearrow$  and  $\Theta'(\dot{e}) = \theta' \geq \max_{f \in \dot{E}, f \nearrow \dot{e}} \Theta(f)$ .

Conversely let  $\langle \dot{E}', \Theta' \rangle$  satisfy the conditions in the curly brace. If  $\dot{E}' = \{\perp\}$ , then  $\langle \dot{E}', \Theta' \rangle \in \dot{X}_{PSF}$ . Otherwise let  $\dot{e} \in \dot{E}'$  be an extended event that has no successor by  $\nearrow$  in  $\dot{E}'$  (such an extended event exists since  $\nearrow$  is acyclic on  $\dot{E}'$ ).  $\langle \dot{E}, \Theta \rangle \stackrel{\text{def}}{=} \langle \dot{E}' \setminus \{\dot{e}\}, \Theta'_{|\dot{E}' \setminus \{\dot{e}\}}$  satisfies the conditions in the curly brace. Assume that  $\langle \dot{E}, \Theta \rangle \in \dot{X}_{PSF}$ . As  $\dot{E}$  is conflict free,  $\bullet \dot{e} \subseteq \uparrow(\dot{E})$ . And as  $\dot{e}$  has no successor by  $\nearrow$  in  $\dot{E}'$ ,  $\dot{e} \subseteq \uparrow(\dot{E})$ . Furthermore  $\Theta'(\dot{e}) \geq \max_{f \in \dot{E}, f \nearrow \dot{e}} \Theta(f)$  and  $PSF(RS_{\Theta'}(\bullet \dot{e} \cup \underline{\dot{e}}), \tau(\dot{e}), \Theta'(\dot{e}))$  holds. Thus  $\langle \dot{E}', \Theta' \rangle = \langle \dot{E} \cup \{\dot{e}\}, \Theta \cup \{(\dot{e}, \Theta'(\dot{e}))\} \rangle \in \dot{X}_{PSF}$ .

**Theorem 4.** *For all  $\dot{e} \stackrel{\text{def}}{=} (B, t) \in \text{cnds}(U_{PSF}) \times T$ ,  $\dot{e} \in U_{PSF}$  iff*

$$\left\{ \begin{array}{l} \nexists \dot{f}, \dot{f}' \in [\dot{e}] \quad \dot{f} \neq \dot{f}' \wedge \bullet \dot{f} \cap \bullet \dot{f}' \neq \emptyset \quad (1) \\ \nexists \dot{e}_0, \dot{e}_1, \dots, \dot{e}_n \in [\dot{e}] \quad \dot{e}_0 \nearrow \dot{e}_1 \nearrow \dots \nearrow \dot{e}_n \nearrow \dot{e}_0 \quad (2) \\ \exists \Theta : [\dot{e}] \rightarrow Q \quad \left\{ \begin{array}{l} \forall \dot{f}, \dot{f}' \in [\dot{e}] \quad \dot{f} \nearrow \dot{f}' \implies \Theta(\dot{f}) \leq \Theta(\dot{f}') \\ \forall \dot{f} \in [\dot{e}] \setminus \{\perp\} \quad PSF(RS_{\Theta}(\bullet \dot{f} \cup \underline{\dot{f}}), \tau(\dot{f}), \Theta(\dot{f})) \end{array} \right. \quad (3) \end{array} \right.$$



*Proof.* Let  $\dot{e} \in U_{PSF}$ . There exists  $\langle \dot{E}, \Theta' \rangle \in \dot{X}_{PSF}$  such that  $\dot{e} \in \dot{E}$ .  $\langle \dot{E}, \Theta' \rangle$  satisfies the conditions in the curly brace of Theorem 3. As  $[\dot{E}] \subseteq \dot{E}$ ,  $[\dot{e}]$  also satisfies them. Then (1) and (2) hold. For (3) a possible  $\Theta$  is  $\Theta'_{|[\dot{e}]}$ .

Conversely if  $\dot{e} \stackrel{\text{def}}{=} (B, t)$  satisfies (1), (2) and (3), consider a possible  $\Theta$  for (3).  $\langle [\dot{e}] \setminus \{\dot{e}\}, \Theta \rangle$  satisfies the curly brace of Theorem 3. Then  $\langle [\dot{e}] \setminus \{\dot{e}\}, \Theta \rangle \in \dot{X}_{PSF}$ . Moreover (1) implies that  $B \subseteq \uparrow([\dot{e}] \setminus \{\dot{e}\})$ . In addition  $\Theta(\dot{e}) \geq \max_{f \in [\dot{e}], f \not\prec \dot{e}} \Theta(f)$  and  $PSF(RS_{\Theta}(B), t, \Theta(\dot{e}))$  holds. Thus  $\langle [\dot{e}], \Theta \rangle \in \dot{X}_{PSF}$  and therefore  $\dot{e} \in U_{PSF}$ .

**Selecting partial state firings.** The definition of extended processes is parameterized by a predicate  $PSF$  on partial state firings: each extended event must correspond to a partial firing that satisfies  $PSF$ , the others are forbidden. A good choice for  $PSF$  takes three notions into account: completeness, redundancy and preservation of concurrency.

*Completeness.* A predicate  $PSF$  on partial state firings is *complete* if for all process  $\langle E, \Theta \rangle \in X$ , there exists an extended process  $\langle \dot{E}, \Theta' \rangle \in \dot{X}_{PSF}$  such that  $\langle h(\dot{E}), \Theta' \circ h_{|\dot{E}}^{-1} \rangle = \langle E, \Theta \rangle$ .

*Redundancy.* Given a predicate  $PSF$  on partial state firings and a process  $\langle E, \Theta \rangle \in X$ , there may exist *several* extended processes  $\langle \dot{E}, \Theta' \rangle \in \dot{X}_{PSF}$  such that  $\langle h(\dot{E}), \Theta' \circ h_{|\dot{E}}^{-1} \rangle = \langle E, \Theta \rangle$ . This is called *redundancy*. In particular, if  $PSF$  contains two partial state firings  $\langle \langle L, \text{dob}, \theta \rangle, t, \theta' \rangle$  and  $\langle \langle L', \text{dob}', \theta \rangle, t, \theta' \rangle$  where  $L' \subsetneq L$  and  $\text{dob}' = \text{dob}_{|L'}$ , then all the extended processes involving  $\langle \langle L, \text{dob}, \theta \rangle, t, \theta' \rangle$  are redundant.

*A trivial choice for  $PSF$  which does not preserve any concurrency.* A trivial complete predicate  $PSF$  is the predicate that demands that the state  $S$  is a global state, and then check that  $t$  can fire at date  $\theta'$  from  $S$ . In addition, this choice gives little redundancy. But the extended events of the extended processes that we obtain in this case are totally ordered by causality. In other words, these processes do not exhibit any concurrency at all. Actually we get what we call firing sequences in interleaving semantics.

*A proposition for  $PSF$ .* What we want is a complete predicate on partial state firings that generates as little redundancy as possible and that exhibits as much concurrency as possible.

We first define a predicate  $PSF'$  on partial state firings as follows:

$PSF'(\langle L, \text{dob}_L, \theta \rangle, t, \theta')$  iff

- $t$  is enabled:  $\bullet t \subseteq L$ ;
- the minimum delay is reached:  $\theta' \geq \text{doe}(t) + \text{efd}(t)$ ;
- the transitions that may consume tokens of  $L$  are disabled or do not overtake the maximum delays:

$$\forall t' \in T \quad \bullet t' \cap L \neq \emptyset \implies \begin{cases} \exists p \in \bullet t' \quad \bar{p} \cap L \neq \emptyset \\ \forall \theta' \leq \max_{p \in \bullet t' \cap L} \text{dob}(p) + \text{bfd}(t') \end{cases}$$

Now we define  $PSF$  by eliminating some redundancy in  $PSF'$ :  
 $PSF(\langle L, dob, \theta \rangle, t, \theta')$  iff  $PSF'(\langle L, dob, \theta \rangle, t, \theta')$  and there exists no  $L' \subsetneq L$  such that  $PSF'(\langle L', dob|_{L'}, \theta \rangle, t, \theta')$ .

It is important that the constraints (see Theorems 3 and 4) can be solved automatically: with the definition of  $PSF$  we have proposed here, the quantifiers ( $\forall$  and  $\exists$ ) on places and transitions expand into disjunctions and conjunctions. The result is a disjunction of conjunctions of linear inequalities on the  $\Theta(\dot{e})$ . When a “max” appears in an inequality, this inequality can be rewritten into the desired form. These systems are shown near the events in Figure 3.

**Theorem 5.** *PSF is a valid, complete predicate on partial state firings.*

*Proof.* The proof of the validity is done in two parts:

1. For all  $\langle \dot{E}, \Theta \rangle \in \dot{X}_{PSF}$ , denote  $\langle M, dob, \theta \rangle$  the global state reached after  $\langle \dot{E}, \Theta \rangle$ .  
 $\langle h(\dot{E}), \Theta \circ h_{|\dot{E}}^{-1} \rangle \in X$  iff

$$\forall t \in T \quad \bullet t \subseteq M \implies \theta \leq \text{dowe}(t) + \text{lfd}(t). \quad (1)$$

2. For all  $\langle \dot{E}, \Theta \rangle \in \dot{X}_{PSF}$ , there exists  $\langle \dot{E}', \Theta' \rangle \in \dot{X}_{PSF}$  which satisfies (1) and such that  $\langle \dot{E}, \Theta \rangle \leq \langle \dot{E}', \Theta' \rangle$ .  
 Consequently  $\langle h(\dot{E}), \Theta \circ h_{|\dot{E}}^{-1} \rangle \leq \langle h(\dot{E}'), \Theta' \circ h_{|\dot{E}'}^{-1} \rangle \in \dot{X}$ .

Here are the proofs for these two points:

1. Let  $\langle \dot{E}, \Theta \rangle \in \dot{X}_{PSF}$  and denote  $\langle M, dob, \theta \rangle$  the global state reached after  $\langle \dot{E}, \Theta \rangle$ .  
 It follows from the definition of the processes that if  $\langle h(\dot{E}), \Theta \circ h_{|\dot{E}}^{-1} \rangle \in X$ , then (1) holds.  
 Conversely, assume that  $\langle \dot{E}, \Theta \rangle$  satisfies (1); choose  $\dot{e} \in \dot{E}$  such that  $\Theta(\dot{e}) = \theta$  and  $\nexists \dot{f} \in \dot{E}$  such that  $\dot{e} \nearrow \dot{f}$ . Then denote  $\langle M', dob', \theta' \rangle$  the global state reached after  $\langle \dot{E} \setminus \{\dot{e}\}, \Theta \rangle$  and let  $t \in T$  such that  $\bullet t \subseteq M'$ . If  $\bullet t \cap \bullet \tau(\dot{e}) = \emptyset$ , then  $\text{dowe}'(t) = \text{dowe}(t) \geq \theta - \text{lfd}(t) \geq \theta' - \text{lfd}(t)$ . Otherwise let  $L \stackrel{\text{def}}{=} \bullet \dot{e} \cup \dot{e}$ . As  $PSF(RS_{\Theta}(L), \tau(\dot{e}), \Theta(\dot{e}))$  holds, then

$$\left\{ \begin{array}{l} \exists p \in \bullet t \quad \bar{p} \cap L \neq \emptyset \\ \vee \theta \leq \max_{p \in \circ t \cap L} \text{dob}'(p) + \text{lfd}(t) \end{array} \right.$$

As  $\bullet t \subseteq M'$ , then  $\nexists p \in \bullet t$  such that  $\bar{p} \cap L \neq \emptyset$ ; thus  $\theta \leq \max_{p \in \circ t \cap L} \text{dob}'(p) + \text{lfd}(t)$ .  
 Hence  $\text{dowe}'(t) = \max_{p \in \circ t} \text{dob}'(p) \geq \max_{p \in \circ t \cap L} \text{dob}'(p) \geq \theta - \text{lfd}(t) \geq \theta' - \text{lfd}(t)$ . As a result  $\langle \dot{E} \setminus \{\dot{e}\}, \Theta \rangle \in \dot{X}_{PSF}$  and satisfies (1).

Assume now that  $\langle E, \Theta' \rangle \stackrel{\text{def}}{=} \langle h(\dot{E} \setminus \{\dot{e}\}), \Theta \circ h_{|\dot{E}}^{-1} \rangle \in X$ . It leads to  $\langle M', dob', \theta' \rangle$ . As  $\bullet \tau(\dot{e}) \subseteq M'$  and  $\theta \geq \theta'$  and  $\theta \geq \text{dowe}'(\tau(\dot{e})) + \text{efd}(\tau(\dot{e}))$  and for all  $t \in T$ ,  $\bullet t \subseteq M' \implies \theta \leq \text{dowe}'(t) + \text{lfd}(t)$ , then  $\tau(\dot{e})$  can fire at date  $\theta$  from  $\langle M', dob', \theta' \rangle$ , which is coded by the event  $(\text{Place}_{|\dot{E}}^{-1}(\tau(\dot{e}), \tau(\dot{e})) = h(\dot{e}))$ . Thus  $\langle h(\dot{E}), \Theta \circ h_{|\dot{E}}^{-1} \rangle \in X$ .

2. Let  $\langle \dot{E}, \Theta \rangle \in \dot{X}_{PSF}$ . If  $\langle \dot{E}, \Theta \rangle$  satisfies (1), then  $\langle \dot{E}', \Theta' \rangle \stackrel{\text{def}}{=} \langle \dot{E}, \Theta \rangle$  fits.  
 Otherwise, choose  $t \in T$  such that  $\bullet t \subseteq M \wedge \theta > \text{dowe}(t) + \text{lfd}(t)$  and such that  $t$  minimizes  $\theta_t \stackrel{\text{def}}{=} \text{dowe}(t) + \text{lfd}(t)$ . Let  $\dot{F} \stackrel{\text{def}}{=} \{\dot{f} \in \dot{E} \mid \Theta(\dot{f}) \leq \theta_t\}$ .  $\langle \dot{F}, \Theta_{|\dot{F}} \rangle \in \dot{X}_{PSF}$ . Denote  $\langle M', \text{dob}', \theta' \rangle$  the global state reached after  $\langle \dot{F}, \Theta_{|\dot{F}} \rangle$ .  $PSF'(\langle M', \text{dob}', \theta' \rangle, t, \theta_t)$  holds. Thus there exists  $L \subseteq M'$  such that  $PSF(\langle L, \text{dob}'_{|L}, \theta' \rangle, t, \theta_t)$  holds. Let  $\dot{e} \stackrel{\text{def}}{=} (\text{Place}_{|\uparrow(\dot{F})}^{-1}(L), t)$ . We will show that  $\langle \dot{E} \cup \{\dot{e}\}, \Theta \cup \{(\dot{e}, \theta_t)\} \rangle \in \dot{X}_{PSF}$ .  $\Theta \cup \{(\dot{e}, \theta_t)\}$  is compatible with  $\nearrow$ : if an extended event  $\dot{f} \in \dot{E}$  is such that  $\dot{f} \cap \bullet \dot{e} \neq \emptyset$ , then  $\Theta(\dot{f}) \leq \theta_t$  and if  $\bullet \dot{f} \cap \dot{e} \neq \emptyset$ , then  $\Theta(\dot{f}) > \theta_t$ . The strict inequality in the second case also guarantees that  $\nearrow$  is acyclic on  $\dot{E} \cup \{\dot{e}\}$ . As a result, we have built an extended process  $\langle \dot{E} \cup \{\dot{e}\}, \Theta \cup \{(\dot{e}, \theta_t)\} \rangle \in \dot{X}_{PSF}$  by adding the event to  $\langle \dot{E}, \Theta \rangle$ .  
 Iterating this until  $\langle \dot{E}, \Theta \rangle$  satisfies (1) terminates if we assume that time diverges: at each step  $\langle \dot{F}, \Theta_{|\dot{F}} \rangle$  satisfies (1), so  $\langle h(\dot{F}), \Theta \circ h_{|\dot{F}}^{-1} \rangle \in X$ ; moreover this process has strictly more events at each step and the dates remain below  $\theta$ , which does not increase.

This ends the proof of the validity of  $PSF$ . Now we have to prove that  $PSF$  is complete. Let  $\langle E, \Theta \rangle \in X$  leading to the global state  $\langle M, \text{dob}, \theta \rangle$ , let  $t \in T$  be a transition that can fire at date  $\theta' \geq \theta$  from  $\langle M, \text{dob}, \theta \rangle$ , and assume that there exists an extended process  $\langle \dot{E}, \Theta' \rangle \in \dot{X}_{PSF}$  such that  $\langle h(\dot{E}), \Theta' \circ h_{|\dot{E}}^{-1} \rangle = \langle E, \Theta \rangle$ .  $PSF'(\langle M, \text{dob}, \theta \rangle, t, \theta')$  holds. Thus there exists  $L \subseteq M$  such that  $PSF(\langle L, \text{dob}_{|L}, \theta \rangle, t, \theta')$  holds. Define  $\dot{e} \stackrel{\text{def}}{=} (\text{Place}_{|\uparrow \dot{E}}^{-1}(L), t)$ .  $\langle \dot{E} \cup \{\dot{e}\}, \Theta' \cup \{(\dot{e}, \theta')\} \rangle \in \dot{X}_{PSF}$  and the event  $h(\dot{e})$  codes the firing of  $t$  at date  $\theta'$  after  $\langle E, \Theta \rangle$ .

### 3.4 Example of unfolding

We come back to our simple example of time Petri net given in Figure 1. Figure 3 shows a prefix of its symbolic unfolding. We have kept all the events concerned with the observations (this filtering is done by considering the time net  $\mathcal{D}(N, O)$  defined in subsection 2.4). To keep the figure readable, we do not show in the unfolding the supplementary places and transitions induced by the observations).

The explanations of Figure 1, given as symbolic processes, correspond to extended processes that appear in the prefix of unfolding of Figure 3. In this figure the rectangles represent the events, and the circles represent the conditions. An arrow from a condition  $b$  to an event  $e$  means that  $b \in \bullet e$ . An arrow from an event  $e$  to a condition  $b$  means that  $b \in e \bullet$ . A line without arrow between a condition  $b$  and an event  $e$  means that  $b \in \underline{e}$ .

The constraint  $PSF(RS_{\Theta}(\bullet \dot{e} \cup \underline{\dot{e}}), \tau(\dot{e}), \Theta(\dot{e}))$  is represented near each event  $e$  of Figure 3. While extracting an extending process from this unfolding, we can solve the conjunction of the constraints appearing on the events of the extended process, plus the constraints that ensure that  $\Theta$  is compatible with  $\nearrow$ . This gives all the possible values for the dates of the events. For example, consider the extended process  $\{e1, e2, e3, e4, e5, e6\}$ . We obtain the

following constraints:

$$\left. \begin{array}{l}
 0 \leq \Theta(e1) - \Theta(\perp) \\
 1 \leq \Theta(e2) - \Theta(\perp) \leq 2 \\
 \Theta(e3) = \max\{\Theta(e1), \Theta(e2)\} \\
 \Theta(e3) - \Theta(e1) \leq 2 \quad (t3 \text{ has not consumed} \\
 \quad \text{the token in } p3 \text{ before } t4 \text{ fires.}) \\
 0 \leq \Theta(e4) - \Theta(e3) \\
 1 \leq \Theta(e5) - \Theta(e3) \leq 2 \\
 \Theta(e6) - \Theta(e4) = 2 \\
 \Theta(e6) - \Theta(e3) \leq 2 \quad (t2 \text{ has not consumed} \\
 \quad \text{the token in } p2 \text{ before } t3 \text{ fires.})
 \end{array} \right\} \forall \dot{e} \quad PSF(RS_{\Theta}(\bullet \dot{e} \cup \underline{\dot{e}}), \tau(\dot{e}), \Theta(\dot{e}))$$

$$\left. \begin{array}{l}
 \Theta(\perp) \leq \Theta(e1) \\
 \Theta(\perp) \leq \Theta(e2) \\
 \Theta(e1) \leq \Theta(e3) \\
 \Theta(e2) \leq \Theta(e3) \\
 \Theta(e3) \leq \Theta(e4) \\
 \Theta(e3) \leq \Theta(e6) \\
 \Theta(e4) \leq \Theta(e6) \\
 \Theta(e3) \leq \Theta(e5) \\
 \Theta(e6) \leq \Theta(e5)
 \end{array} \right\} \begin{array}{l}
 \forall \dot{e}, \dot{e}' \quad \dot{e} \nearrow \dot{e}' \implies \Theta(\dot{e}) \leq \Theta(\dot{e}'). \\
 \text{Notice that } e6 \nearrow e5.
 \end{array}$$

These constraints can be simplified into:

$$\left\{ \begin{array}{l}
 \Theta(\perp) \leq \Theta(e1) \\
 1 \leq \Theta(e2) - \Theta(\perp) \leq 2 \\
 \Theta(e3) = \max\{\Theta(e1), \Theta(e2)\} \\
 \Theta(e4) = \Theta(e3) \\
 \Theta(e6) = \Theta(e4) + 2 \\
 \Theta(e5) = \Theta(e3) + 2
 \end{array} \right.$$

The three maximal extended processes of Figure 3 share the prefix  $\{e1, e2, e3, e4, e5\}$ . The first extended process contains also  $e7$ . It corresponds to the second explanation of Figure 1. The second extended process contains the prefix, plus  $e6$  and the third contains the prefix, plus  $e8$ . These two extended processes correspond to the same explanation: the first of Figure 1. This is what we have called redundancy. After solving the linear constraints we see that the second occurrence of  $t1$  must have occurred immediately after  $t4$  has fired and the second occurrence of  $t2$  must have fired 2 time units later. Actually the extended process with  $e6$  and the one with  $e8$  only differ by the fact that transition  $t3$  has fired *before*  $t2$  in the first one, whereas  $t3$  has fired *after*  $t2$  in the second one. Because of transition  $t4$ , the firing of  $t2$  has a strong influence on the firing of  $t3$ . This is the reason why there are too distinct cases in the unfolding.

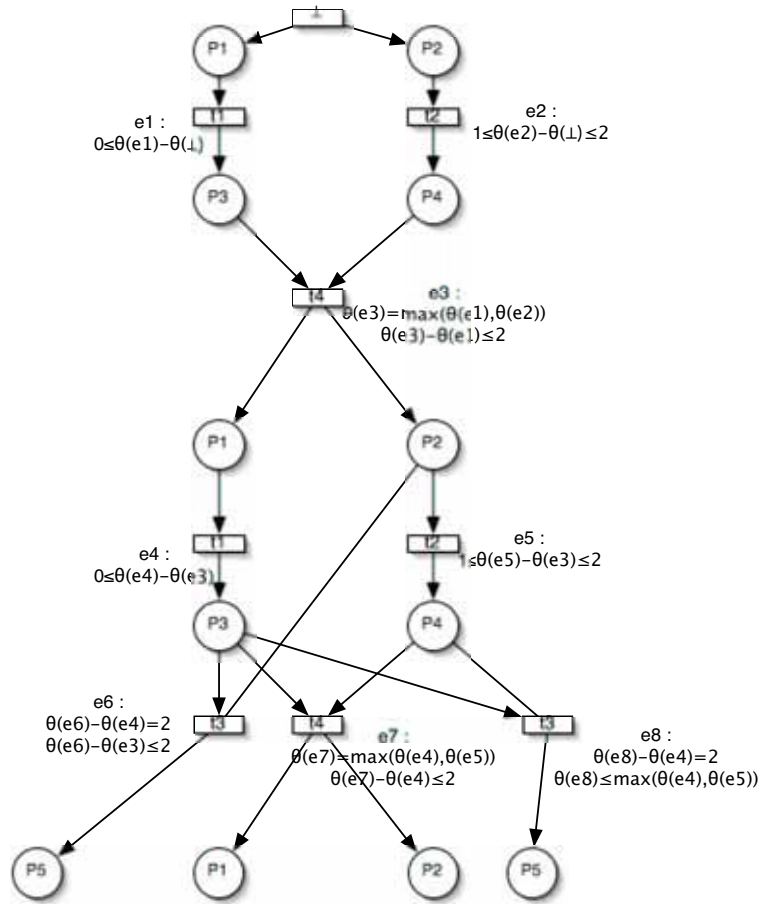

Fig. 3. A prefix of the symbolic unfolding of the time Petri net of Figure 1.

## 4 Conclusion

We have presented a possible approach to the supervision/diagnosis of timed systems, using safe time Petri nets. In such nets, time constraints are given by interval of nonnegative rationals and are used to restrict the set of behaviours. The diagnosis problem is to recover the possible behaviours from a set of observations. We consider that the observations are given as a partial order (without any timing information) from the activity of several sensors. The

goal of the supervisor is to select the possible timed behaviours of the model, which do not contradict the observations: i.e. presents the same set of events labelled by the alarms and orders the events in the same direction that the sensors do. This goal is achieved by considering a symbolic unfolding of time Petri nets, which is restricted by the observations. The result is a set of explanations, which explicit the causalities (both structural and temporal) between the observations. At the same time, our algorithm infers the possible delays before the firing of the transitions associated with them. Up to our knowledge, our symbolic unfolding for safe time Petri nets is original, and its application to compute symbolic explanations too.

A prototype implementation exists (a few thousands lines of Lisp code) and we plan to use it on real case studies. Another project is to define an algorithm to produce a complete finite prefix of the unfolding [9], which could be used for other applications than diagnosis (for which we do not need this notion since observations are finite sets).

At longer term, the notion of temporal diagnosis could be refined and revisited when considering timed distributed systems, in which alarms could bring a time information.

## References

1. Tuomas Aura and Johan Lilius. Time processes for time Petri nets. In *ICATPN*, pages 136–155, 1997.
2. Paolo Baldan, Andrea Corradini, and Ugo Montanari. Contextual petri nets, asymmetric event structures, and processes. *Inf. Comput.*, 171(1):1–49, 2001.
3. A. Benveniste, E. Fabre, C. Jard, and S. Haar. Diagnosis of asynchronous discrete event systems, a net unfolding approach. *IEEE Transactions on Automatic Control*, 48(5):714–727, May 2003.
4. Bernard Berthomieu and Michel Diaz. Modeling and verification of time dependent systems using time Petri nets. *IEEE Trans. Software Eng.*, 17(3):259–273, 1991.
5. Bernard Berthomieu and François Vernadat. State class constructions for branching analysis of time Petri nets. In *TACAS*, pages 442–457, 2003.
6. Eike Best. Structure theory of Petri nets: the free choice hiatus. In *Proceedings of an Advanced Course on Petri Nets: Central Models and Their Properties, Advances in Petri Nets 1986-Part I*, pages 168–205, London, UK, 1987. Springer-Verlag.
7. Thomas Chatain and Claude Jard. Symbolic diagnosis of partially observable concurrent systems. In *FORTE*, pages 326–342, 2004.
8. Joost Engelfriet. Branching processes of Petri nets. *Acta Inf.*, 28(6):575–591, 1991.
9. Javier Esparza, Stefan Römer, and Walter Vogler. An improvement of McMillan’s unfolding algorithm. In *TACAS*, pages 87–106, 1996.
10. Hans Fleischhack and Christian Stehno. Computing a finite prefix of a time Petri net. In *ICATPN*, pages 163–181, 2002.
11. P.M. Merlin and D.J. Farber. Recoverability of communication protocols – implications of a theoretical study. *IEEE Transactions on Communications*, 24, 1976.
12. B. Pradin-Chézalviel, R. Valette, and L.A. Künzle. Scenario duration characterization of t-timed Petri nets using linear logic. In *IEEE PNPM*, pages 208–217, 1999.
13. Alexei Semenov and Alexandre Yakovlev. Verification of asynchronous circuits using time Petri net unfolding. In *DAC’96: Proceedings of the 33rd annual conference on Design automation*, pages 59–62, New York, NY, USA, 1996. ACM Press.

14. Walter Vogler. Partial order semantics and read arcs. In *MFCS*, pages 508–517, 1997.