

Rational Semimodules over the Max-Plus Semiring and Geometric Approach of Discrete Event Systems

Stéphane Gaubert, Ricardo David Katz

► **To cite this version:**

Stéphane Gaubert, Ricardo David Katz. Rational Semimodules over the Max-Plus Semiring and Geometric Approach of Discrete Event Systems. [Research Report] RR-4519, INRIA. 2002. inria-00072069

HAL Id: inria-00072069

<https://hal.inria.fr/inria-00072069>

Submitted on 23 May 2006

HAL is a multi-disciplinary open access archive for the deposit and dissemination of scientific research documents, whether they are published or not. The documents may come from teaching and research institutions in France or abroad, or from public or private research centers.

L'archive ouverte pluridisciplinaire **HAL**, est destinée au dépôt et à la diffusion de documents scientifiques de niveau recherche, publiés ou non, émanant des établissements d'enseignement et de recherche français ou étrangers, des laboratoires publics ou privés.

Rational Semimodules over the Max-Plus Semiring and Geometric Approach of Discrete Event Systems

Stéphane Gaubert — Ricardo Katz

N° 4519

Août 2002

THÈME 4



*Rapport
de recherche*

Rational Semimodules over the Max-Plus Semiring and Geometric Approach of Discrete Event Systems

Stéphane Gaubert* , Ricardo Katz†

Thème 4 — Simulation et optimisation
de systèmes complexes
Projet Metalau

Rapport de recherche n° 4519 — Août 2002 — 27 pages

Abstract: We introduce rational semimodules over semirings whose addition is idempotent, like the max-plus semiring. We say that a subsemimodule of the free semimodule \mathcal{S}^n over a semiring \mathcal{S} is rational if it has a generating family that is a rational subset of \mathcal{S}^n , \mathcal{S}^n being thought of as a monoid under the entrywise product. We show that for various semirings of max-plus type whose elements are integers, rational semimodules are stable under the natural algebraic operations (union, product, direct and inverse image, intersection, projection, etc). Rational semimodules are a tool to extend the geometric approach of linear control to discrete event systems. In particular, we show that the reachable and observable spaces of max-plus linear dynamical systems are rational.

Key-words: Invariant spaces, reachability, geometric control, rational sets, Presburger arithmetics, max-plus algebra, discrete event systems.

* INRIA, Domaine de Voluceau, 78153, Le Chesnay Cédex, France. Email: Stephane.Gaubert@inria.fr

† Dep. of Mathematics, Universidad Nacional de Rosario, Avenida Pellegrini 250, 2000 Rosario, Argentina.
Email: rkatz@fceia.unr.edu.ar

Semimodules rationnels sur le semi-anneau max-plus et approche géométrique des systèmes à événements discrets

Résumé : Nous introduisons la classe des semimodules rationnels sur des semi-anneaux dont l'addition est idempotente, tels que le semi-anneau max-plus. Nous disons qu'un sous semi-module d'un semimodule libre \mathcal{S}^n sur un semi-anneau \mathcal{S} est rationnel s'il admet une famille génératrice qui est une partie rationnelle de \mathcal{S}^n , \mathcal{S}^n étant vu comme un monoïde pour le produit coordonnée par coordonnée. Nous montrons que pour des semi-anneaux de type max-plus dont les éléments sont des entiers, les semi-modules rationnels sont stables pour les opérations algébriques naturelles (union, produit, image directe et réciproque, intersection, projection, etc.) Les semi-modules rationnels sont un outil pour étendre au cas des systèmes à événements discrets l'approche géométrique en commande linéaire. Nous montrons ainsi que les espaces accessibles et observables associés à des systèmes dynamiques max-plus linéaires sont rationnels.

Mots-clés : Espaces invariants, accessibilité, approche géométrique, ensembles rationnels, arithmétique de Presburger, algèbre max-plus, systèmes à événements discrets

Contents

1	Introduction	3
2	Presburger Logic over Idempotent Semirings	4
3	Closure Properties of Rational Semimodules	9
4	Examples and Counter Examples	14
4.1	Reachable and Observable Spaces of Max-Plus Linear Discrete Event Systems	14
4.2	Example of reachable space and observable congruence	15
4.3	Manufacturing system interpretation	19
4.4	Rational semimodules over \mathbb{R}_{\max} need not be stable by direct image	20
4.5	Noncommutative reachable spaces need not be rational	21

1 Introduction

In this paper, we define a new class of semimodules over max-plus type semirings, that we call *rational semimodules*, and study their properties.

This work is motivated by the max-plus algebraic approach of discrete event systems. It is well known (see in particular [CMQV89, BCOQ92, Gun98, CGQ99]) that a subclass of discrete event systems subject to synchronization constraints, comprising examples of manufacturing systems, transportation networks, and computer networks, can be modeled by max-plus linear dynamical systems. An open question (see [CGQ99]) is to develop the analogue of Wonham’s geometric approach [Won85] for the control of max-plus linear dynamical systems. As in classical linear system theory, many control problems can be phrased in terms of semimodules (semimodules over semirings are defined like modules over rings, *mutatis mutandis*). A difficulty of this approach, however, is that max-plus semimodules have very different properties from vector spaces. In particular, a subsemimodule of a free finitely generated semimodule need not be free or finitely generated, and so even the simplest spaces in control theory, the reachability space and the observability “space” or congruence, need not be finitely generated (see the examples in §4.2). Therefore, new algebraic tools are needed to “replace” the theory of rank which is so useful in classical linear control, and effective methods must be designed to handle semimodules with an infinite number of generators.

Several results are known on max-plus semimodules, including notions of basis and extremal points [Mol88, Wag91, GP97, Gau98], direct sums [CGQ96], projective semimodules [CGQ97], separation theorems [Zim77, SS92, LMS00, CGQ01]. However, the issue of computing effectively with non finitely generated semimodules does not seem to have been raised previously in the literature.

In this paper, we extend the notion of finitely generated semimodule as follows: we say that a semimodule $\mathcal{X} \subset \mathcal{S}^n$ is *rational* if it has a set of generators that is a rational subset

of S^n , where S^n is thought of as a monoid under the entrywise product, see Definition 3.1 below. Rational sets over monoids, and in particular, rational sets of $(\mathbb{N}^k, +)$ or $(\mathbb{Z}^k, +)$, or *semilinear* sets, are well known objects in computer science, see [GS66, ES69]. The typical semiring to which our notions apply is the semiring of max-plus integers, $\mathbb{Z} \cup \{-\infty\}$, equipped with max as addition, and the usual addition as multiplication: then, up to technical details related to the infinite element, rational semimodules are semimodules generated by semilinear sets of \mathbb{Z}^n .

We show that rational semimodules are closed under the natural algebraic operations, like union, direct sum, direct and inverse image, intersection, projection, and by taking the orthogonal. Whereas the closure under union, direct sum, and direct image, can be proved in a natural way, our proof of the other properties relies on Presburger arithmetics, which leads to expensive algorithms [Opp78]. Finding direct, computationally more efficient proofs, leads to interesting combinatorial problems. In fact, even for finitely generated semimodules, algorithmic issues remain difficult, see Remark 3.9 below.

The paper is organized as follows. In §2, we recall classical definitions and facts about rational sets and idempotent semirings, and establish preliminary results. We extend the definition of the Presburger logic to a naturally ordered idempotent semiring \mathcal{S} , and show, as a slight extension of the theorem of Ginzburg and Spanier [GS66], that idempotent semirings like $(\mathbb{Z} \cup \{-\infty\}, \max, +)$ have the property that the subsets of S^n defined by formulas of the first order logic of $(\mathcal{S}, e, \otimes, \preceq)$, where e is the unit, \otimes the product, and \preceq the natural order, are exactly the rational subsets of S^n . In §3, we use these results to show that the class of rational semimodules is closed under various algebraic operations. In §4, we illustrate the results by discrete event systems problems, and give various examples and counter examples. We show in §4.1 that max-plus reachable spaces and observable congruences are rational, and then, in §4.2, we give examples of reachable semimodules and observable congruences. In §4.3, we illustrate the reachability and observability notions by discussing a simple example of manufacturing systems (three machines in tandem). In §4.4, we give counter examples showing that the integrity assumptions that we used are useful, and in §4.5, we give a counter example showing that the noncommutative analogues of reachable spaces need not be rational.

2 Presburger Logic over Idempotent Semirings

Let us recall some definitions and results. Let (M, \cdot) be a monoid, i.e. a set with an associative multiplication and a two sided unit 1_M . The class of *rational* subsets of M is the least class \mathcal{R} of subsets of M satisfying the following conditions:

1. If U is a finite set then $U \in \mathcal{R}$;
2. If $U, V \in \mathcal{R}$ then $U \cup V \in \mathcal{R}$;
3. If $U, V \in \mathcal{R}$ then $U \cdot V = \{m \mid m = u \cdot v, u \in U, v \in V\} \in \mathcal{R}$;
4. If $U \in \mathcal{R}$ then $U^* = U^0 \cup U \cup U^2 \cup \dots \in \mathcal{R}$,

where by convention $U^0 = \{1_M\}$. A subset $U \subset M$ is called *semilinear* if it can be written as a finite union of sets of the form $\{x\} \cdot B^*$, where $x \in M$ and B is a finite subset of M . We shall use throughout the paper the following classical result (see [ES69]): in a commutative monoid, rational and semilinear subsets coincide.

A *semiring* is a set \mathcal{S} equipped with two internal composition laws \oplus and \otimes , called addition and multiplication respectively, such that \mathcal{S} is a commutative monoid for addition, \mathcal{S} is a monoid for multiplication, multiplication distributes over addition, and the neutral element for addition is absorbing for multiplication. We will denote by ε the neutral element for addition and by e the neutral element for multiplication. We will sometimes denote by $(\mathcal{S}, \oplus, \otimes)$ or $(\mathcal{S}, \oplus, \otimes, \varepsilon, e)$ the semiring \mathcal{S} . In this paper, we are mostly interested in the max-plus semiring \mathbb{R}_{\max} , which is the set $\mathbb{R} \cup \{-\infty\}$ equipped with $\oplus = \max$ and $\otimes = +$. The semiring \mathbb{R}_{\max} is *idempotent*: $x \oplus x = x$ for all $x \in \mathcal{S}$. An idempotent semiring $(\mathcal{S}, \oplus, \otimes)$ is equipped with the *natural order* \preceq , which is defined by:

$$x \preceq y \Leftrightarrow x \oplus y = y.$$

With this order, $x \oplus y$ is the least upper bound of the set $\{x, y\}$ (see [BCOQ92]).

Several variants of the max-plus semiring \mathbb{R}_{\max} can be found in the literature. Indeed, to any submonoid $(M, +)$ of $(\mathbb{R}, +)$ is associated a semiring with set of elements $M \cup \{-\infty\}$, and laws $\oplus = \max$, $\otimes = +$. We denote this semiring by M_{\max} . Symmetrically, the semiring M_{\min} is the set $M \cup \{+\infty\}$, equipped with $\oplus = \min$ and $\otimes = +$. For instance, taking $M = \mathbb{N}$, we get $\mathbb{N}_{\min} = (\mathbb{N} \cup \{+\infty\}, \min, +)$, a semiring known as the *tropical semiring* after the work of Simon [Sim78] (see [Pin98] for a recent overview). The semiring $\mathbb{Z}_{\min} = (\mathbb{Z} \cup \{+\infty\}, \min, +)$ is sometimes called the *equatorial semiring* [Kro93, Kro94]. One can also add a maximal element (for the natural order) to the semirings M_{\max} and M_{\min} : this yields the semirings $\bar{M}_{\max} = (M \cup \{\pm\infty\}, \max, +)$ and $\bar{M}_{\min} = (M \cup \{\pm\infty\}, \min, +)$. Since the zero element is $\varepsilon = -\infty$ in \bar{M}_{\max} and $\varepsilon = +\infty$ in \bar{M}_{\min} , in these semirings, the value of $(-\infty) + (+\infty) = (+\infty) + (-\infty)$ is determined by the rule $\varepsilon \otimes x = x \otimes \varepsilon = \varepsilon$.

It is convenient to formalize the class of semirings to which our results apply, by extending the classical definition of Presburger logic, as follows. We refer the reader to [GS66, B02] for more information about Presburger logic. Our presentation follows [GS66].

Let $(\mathcal{S}, \oplus, \otimes, \varepsilon, e)$ be an idempotent commutative semiring with natural order \preceq . We consider formulas or statements about the elements of \mathcal{S} . The set \mathcal{P} of *first-order logic formulas* of $(\mathcal{S}, e, \otimes, \preceq)$ is by definition the smallest class of formulas satisfying the following five conditions:

1. For any nonnegative integers $k_i, r_i, 1 \leq i \leq n$,

$$\bigotimes_{i=1}^n x_i^{k_i} \preceq \bigotimes_{j=1}^n x_j^{r_j} \tag{1}$$

is a formula in \mathcal{P} . Here $x_i^{k_i}$ denotes $x_i \otimes \dots \otimes x_i$, where x_i is repeated k_i times, and we adopt the convention $x_i^0 = e$. The free variables of this formula are x_1, \dots, x_n ;

2. If P_1, P_2 are in \mathcal{P} , so is their conjunction $P_1 \wedge P_2$. The set of free variables of $P_1 \wedge P_2$ is the set of free variables of P_1 union the set of free variables of P_2 ;
3. If P_1, P_2 are in \mathcal{P} , so is their disjunction $P_1 \vee P_2$. The set of free variables of $P_1 \vee P_2$ is the set of free variables of P_1 union the set of free variables of P_2 ;
4. If P is in \mathcal{P} , so is its negation $\neg P$. The free variables of $\neg P$ are the free variables of P .
5. If $P(x_1, \dots, x_n)$ is in \mathcal{P} and has the free variables x_1, \dots, x_n , then for each $1 \leq i \leq n$, the formula $(\exists x_i)P(x_1, \dots, x_n)$ is in \mathcal{P} and its free variables are x_j for $1 \leq j \leq n$ and $j \neq i$.

In the sequel, we will simply call a formula of \mathcal{P} a *Presburger formula* of $(\mathcal{S}, e, \otimes, \preceq)$.

Remark 2.1. If $P(x_1, \dots, x_n)$ is in \mathcal{P} , then for each $1 \leq i \leq n$, the formula $(\forall x_i)P(x_1, \dots, x_n)$ is regarded as a first-order logic formula of $(\mathcal{S}, e, \otimes, \preceq)$ because it is equivalent to

$$\neg(\exists x_i)(\neg P(x_1, \dots, x_n)).$$

Similarly if P and Q are in \mathcal{P} , then $P \Rightarrow Q$ is regarded as a first-order logic formula of $(\mathcal{S}, e, \otimes, \preceq)$.

Remark 2.2. The formula $x_{n+1} = \bigoplus_{i=1}^n x_i$ is regarded as a first-order logic formula of $(\mathcal{S}, e, \otimes, \preceq)$ because it is equivalent to

$$(x_1 \preceq x_{n+1}) \wedge \dots \wedge (x_n \preceq x_{n+1}) \wedge \\ \{(\forall x_{n+2}) [((x_1 \preceq x_{n+2}) \wedge \dots \wedge (x_n \preceq x_{n+2})) \Rightarrow x_{n+1} \preceq x_{n+2}]\}.$$

For readability, we will allow the use of arbitrary letters (rather than x_1, x_2, \dots) for the variables of formulas, so that we will regard for instance $y = \bigoplus_{i=1}^n x_i$ as a Presburger formula with free variables x_1, \dots, x_n, y .

We say that a subset $D \subset \mathcal{S}^n$ is *definable* in the first-order logic of $(\mathcal{S}, e, \otimes, \preceq)$ if there exists a formula $P(x_1, \dots, x_n)$ in \mathcal{P} , with n free variables x_1, \dots, x_n , such that:

$$D = \{(x_1, \dots, x_n) \in \mathcal{S}^n \mid P(x_1, \dots, x_n) \text{ is true} \} .$$

Definition 2.3. An idempotent commutative semiring $(\mathcal{S}, \oplus, \otimes, e, \varepsilon)$ has the *Presburger property* if the subsets of \mathcal{S}^n definable in the first-order logic of $(\mathcal{S}, e, \otimes, \preceq)$ are precisely the rational sets of (\mathcal{S}^n, \otimes) .

We shall need the following extension of the theorem of Ginzburg and Spanier [GS66], which states that the rational subsets of $(\mathbb{N}^n, +)$ are precisely the subsets definable in the classical Presburger arithmetics.

Theorem 2.4. *The idempotent semirings $\mathbb{Z}_{\max} = (\mathbb{Z} \cup \{-\infty\}, \max, +)$, $\bar{\mathbb{Z}}_{\max} = (\mathbb{Z} \cup \{\pm\infty\}, \max, +)$, $\mathbb{N}_{\max} = (\mathbb{N} \cup \{-\infty\}, \max, +)$, $\bar{\mathbb{N}}_{\max} = (\mathbb{N} \cup \{\pm\infty\}, \max, +)$, and $\mathbb{N}_{\min} = (\mathbb{N} \cup \{+\infty\}, \min, +)$ all have the Presburger property.*

The proof of Theorem 2.4 relies on the following:

Lemma 2.5. *A subset $R \subset ((\mathbb{Z} \cup \{\pm\infty\})^n, +)$ is rational if and only if it can be written as a finite union of sets of the form*

$$\{a\} + \{\bar{r}_1, \dots, \bar{r}_k\}^* , \quad (2)$$

where $a \in (\mathbb{Z} \cup \{\pm\infty\})^n$ and $\bar{r}^1, \dots, \bar{r}^k \in \mathbb{Z}^n$.

Proof. Using the characterization of rational sets as semilinear sets, it suffices to show that any set $\{b\} + \{r^1, \dots, r^k\}^*$, with $b, r^1, \dots, r^k \in (\mathbb{Z} \cup \{\pm\infty\})^n$, can be rewritten as a finite union of sets of the form (2). Recall the following classical *rational identities*

$$(A \cup B)^* = A^* + B^* \quad (3)$$

$$A^* = A^0 \cup (A + A^*) \quad (4)$$

(identity (3) holds for all subsets A, B of a commutative monoid, whereas (4) holds for subsets A of arbitrary monoids, see e.g. [Con71] for more details on rational identities). Using (3) and (4), we can write:

$$\begin{aligned} \{b\} + \{r^1, \dots, r^k\}^* &= \{b\} \cup \bigcup_{1 \leq i \leq k} \{b + r^i\} + \{r^1, \dots, r^k\}^* \\ &= \{b\} \cup \bigcup_{1 \leq i \leq k} (\{b + r^i\} + \{r^i\}^* + \{r^j \mid 1 \leq j \leq k, j \neq i\}^*) . \end{aligned} \quad (5)$$

Now, for all $r \in (\mathbb{Z} \cup \{\pm\infty\})^n$, denote by $\bar{r} \in \mathbb{Z}^n$ the vector obtained by replacing infinite coordinates of r by an arbitrary finite value (say 0). One easily gets, using the fact that $(-\infty) + x = -\infty$ for all $x \in \bar{\mathbb{Z}}_{\max}$, and $(+\infty) + x = (+\infty) + (+\infty)$, for all $x \in \mathbb{Z}$, that

$$\{b + r\} + \{r\}^* = \{b + \bar{r}\} + \{\bar{r}\}^* \quad (6)$$

Using several times the transformations (3), (5) and (6), we express $\{b\} + \{r^1, \dots, r^k\}^*$ as a finite union of sets of the form $\{a\} + \{\bar{r}^1, \dots, \bar{r}^k\}^*$, with $a \in (\mathbb{Z} \cup \{\pm\infty\})^n$. \square

Proof of Theorem 2.4. By comparison with the result of Ginzburg and Spanier, the only new difficulty is to take care of the $\pm\infty$ elements. Let us consider the case of $\bar{\mathbb{Z}}_{\max}$. The other cases can be proved in the same way.

As a preliminary result, we first check that every element of $\mathbb{Z} \cup \{\pm\infty\}$ is definable by a Presburger formula of $(\mathbb{Z} \cup \{\pm\infty\}, 0, +, \leq)$. We can regard $y = +\infty$ and $y = -\infty$ as Presburger formulas, since $y = +\infty$ (resp. $y = -\infty$) is equivalent to $(\forall x)(x \leq y)$ (resp. $(\forall x)(x \geq y)$). Similarly, $y = 1$, which is equivalent to $\neg(y \leq 0) \wedge (\forall x)(\neg(x \leq 0) \Rightarrow y \leq x)$, will be seen as a Presburger formula. We note that in $\bar{\mathbb{Z}}_{\max}$, the inequality (1) becomes:

$$\sum_{i=1}^n k_i x_i \leq \sum_{j=1}^n r_j x_j . \quad (7)$$

Therefore, for any positive integer r , $y = r$, which is equivalent to $(\exists z)(z = 1) \wedge (y = rz)$, will be seen as a Presburger formula, as well as $y = -r$, which is equivalent to $(\exists z)(z = r) \wedge (0 = y + z)$. Finally, we denote by $\text{Nat}(y)$ the Presburger formula $(y \geq 0) \wedge \neg(y \geq +\infty)$, which expresses the property that y is a natural number.

We next show that every semilinear set of $((\mathbb{Z} \cup \{\pm\infty\})^n, +)$ is definable by a Presburger formula of $(\mathbb{Z} \cup \{\pm\infty\}, 0, +, \leq)$. Since the family of sets definable in the first-order logic of $(\mathbb{Z} \cup \{\pm\infty\}, 0, +, \leq)$ is closed under union, thanks to Lemma 2.5, it is enough to show the following:

(Claim C): *For all $a \in (\mathbb{Z} \cup \{\pm\infty\})^n$, and $\bar{r}^1, \dots, \bar{r}^k \in \mathbb{Z}^n$, the set (2) is definable by a formula of the first-order logic of $(\mathbb{Z} \cup \{\pm\infty\}, 0, +, \leq)$.*

Indeed, for each $1 \leq i \leq n$ let us define the set $J_i = \{1 \leq j \leq k \mid r_i^j < 0\}$. Then, the vector $(x_1, \dots, x_n) \in (\mathbb{Z} \cup \{\pm\infty\})^n$ belongs to $\{a\} + \{\bar{r}^1, \dots, \bar{r}^k\}^*$ if and only if

$$(\exists y_1), \dots, (\exists y_k) (\text{Nat}(y_1) \wedge \dots \wedge \text{Nat}(y_k) \wedge \bigwedge_{1 \leq i \leq n} P_i(x_i, y_1, \dots, y_k)) ,$$

where:

$$P_i(x_i, y_1, \dots, y_k) = (\exists z_i) \left((z_i = a_i) \wedge (x_i + \sum_{j \in J_i} (-\bar{r}_i^j) y_j = z_i + \sum_{j \notin J_i} \bar{r}_i^j y_j) \right). \quad (8)$$

Since (7) is a Presburger formula of $(\mathbb{Z} \cup \{\pm\infty\}, 0, +, \leq)$, so does (8), so Claim C is proved. Therefore, every rational set of $((\mathbb{Z} \cup \{\pm\infty\})^n, +)$ is definable by a Presburger formula of $(\mathbb{Z} \cup \{\pm\infty\}, 0, +, \leq)$.

Let us now show that every subset of $(\mathbb{Z} \cup \{\pm\infty\})^n$ definable by a Presburger formula of $(\mathbb{Z} \cup \{\pm\infty\}, 0, +, \leq)$ is a rational set of the commutative monoid $((\mathbb{Z} \cup \{\pm\infty\})^n, +)$. As the family of rational sets of $((\mathbb{Z} \cup \{\pm\infty\})^n, +)$ is closed with respect to union, intersection and complementation (see [ES69]) and as the projection of a rational set of $((\mathbb{Z} \cup \{\pm\infty\})^n, +)$ is a rational set, it is enough to show that for all nonnegative integers, $r_i, k_i, 1 \leq i \leq n$, the set S of solutions of

$$\sum_{i=1}^n k_i x_i \leq \sum_{j=1}^n r_j x_j \quad (9)$$

is a rational set of $((\mathbb{Z} \cup \{\pm\infty\})^n, +)$. To see this, consider the map $\kappa : \mathbb{Z} \cup \{\pm\infty\} \rightarrow \{0, \pm\infty\}$, which fixes $-\infty$ and $+\infty$, and sends any finite number to 0. We extend κ to a map $(\mathbb{Z} \cup \{\pm\infty\})^n \rightarrow \{0, \pm\infty\}^n$ by making κ act on each entry. We shall call $\kappa(x)$ the *pattern* of $x \in (\mathbb{Z} \cup \{\pm\infty\})^n$. To show that S is rational, it is enough to prove that for every $p \in \{0, \pm\infty\}^n$, the set of solutions with pattern p , $S_p = S \cap \kappa^{-1}(p)$, is rational. Let $I(p) = \{1 \leq i \leq n \mid \kappa(p)_i = \pm\infty\}$, and let $J(p)$ denote the complement of $I(p)$ in $\{1, \dots, n\}$. When x has pattern p , (9) can be rewritten as

$$a + \sum_{i \in J(p)} k_i x_i \leq b + \sum_{j \in J(p)} r_j x_j , \quad (10)$$

where $a = \sum_{i \in I(p)} k_i p_i$ and $b = \sum_{j \in J(p)} r_j p_j$. Note that a and b can take values only in $\{0, \pm\infty\}$ ($a = 0$ if $k_i = 0$ for all $i \in I(p)$, and $b = 0$ if $r_j = 0$ for all $j \in J(p)$), due to the convention $0 \times x_i = 0$ which is implied by the convention $x_i^0 = e$ that we made when writing (1)). Note also that an empty sum is equal to 0, by convention. Only the following cases can occur.

Case 1. $a = -\infty$. Then, (10) is automatically satisfied, and we conclude that $S_p = \kappa^{-1}(p) = \{x \in (\mathbb{Z} \cup \{\pm\infty\})^n \mid x_i = p_i \text{ for } i \in I(p) \text{ and } x_i \in \mathbb{Z} \text{ for } i \in J(p)\}$. The set S_p , which is a Cartesian product of rational sets of commutative monoids, is rational. (Indeed, S_p is the Cartesian product of one element subsets of $(\mathbb{Z} \cup \{\pm\infty\}, +)$, which are obviously rational, and of copies of $\mathbb{Z} = \{-1, 1\}^*$ which is a rational subset of the monoid $(\mathbb{Z} \cup \{\pm\infty\}, +)$.)

Case 2. $a \neq -\infty$. We split this case into subcases:

Case 2.1. $a \neq -\infty$ and $b = -\infty$. Then, $S_p = \emptyset$.

Case 2.2. $a \neq -\infty$ and $b = +\infty$. Then, $S_p = \kappa^{-1}(p)$, and we proved in Case 1 that S_p is rational.

Case 2.3. $a \neq -\infty$ and $b = 0$. We again split this subcase.

Case 2.3.1. $a = +\infty$ and $b = 0$. Then, $S_p = \emptyset$.

Case 2.3.2. $a = 0$ and $b = 0$. Then, $S_p = \{x \in (\mathbb{Z} \cup \{\pm\infty\})^n \mid x_i = p_i \text{ for } i \in I(p), x_i \in \mathbb{Z} \text{ for } i \in J(p), \text{ and } \sum_{i \in I(p)} k_i x_i \leq \sum_{j \in J(p)} r_j x_j\}$. By the classical result of [GS66], the set of finite integer solutions of an equation of the form (7) is rational, therefore, $T = \{x \in \mathbb{Z}^{J(p)} \mid \sum_{i \in I(p)} k_i x_i \leq \sum_{j \in J(p)} r_j x_j\}$ is a rational subset of $\mathbb{Z}^{J(p)}$. Since S_p is the Cartesian product of T by one element sets, S_p is rational.

Thus, the set $S = \bigcup_{p \in \{0, \pm\infty\}^n} S_p$ of solutions of (9) is a rational set of $((\mathbb{Z} \cup \{\pm\infty\})^n, +)$. \square

Example 2.6. The idempotent semirings \mathbb{R}_{\max} and $\mathbb{Q}_{\max} = (\mathbb{Q} \cup \{-\infty\}, \max, +)$ do not have the Presburger property, because there is no way to define the rational set $\{1\}$ by a Presburger formula. Another example of idempotent semiring which does not have the Presburger property is $\mathcal{S} = ((\mathbb{Z} \cup \{-\infty\})^2, \max, +)$, where \max denotes the law $(\mathbb{Z} \cup \{-\infty\})^2 \times (\mathbb{Z} \cup \{-\infty\})^2 \rightarrow (\mathbb{Z} \cup \{-\infty\})^2$ which does entrywise \max . In this semiring, the set $\{(1, 0)\}$ cannot be defined by a Presburger formula (for symmetry reasons, there is no way to distinguish $(1, 0)$ from $(0, 1)$ using Presburger formulas).

3 Closure Properties of Rational Semimodules

Let us recall some definitions. A (left) *semimodule* \mathcal{X} over a semiring $(\mathcal{S}, \oplus, \otimes, \varepsilon_{\mathcal{S}}, e)$ is a commutative monoid $(\mathcal{X}, \oplus, \varepsilon_{\mathcal{X}})$, equipped with a map $\mathcal{S} \times \mathcal{X} \rightarrow \mathcal{X}$, $(\lambda, x) \rightarrow \lambda x$ (left action),

that satisfies

$$(\lambda \otimes \mu)x = \lambda(\mu x) , \quad (11a)$$

$$\lambda(x \oplus y) = \lambda x \oplus \lambda y, (\lambda \oplus \mu)x = \lambda x \oplus \mu x , \quad (11b)$$

$$\varepsilon_S x = \varepsilon_{\mathcal{X}}, \lambda \varepsilon_{\mathcal{X}} = \varepsilon_{\mathcal{X}}, e x = x , \quad (11c)$$

for all $x, y \in \mathcal{X}$, $\lambda, \mu \in \mathcal{S}$. In the sequel, we will denote by ε both the zero element ε_S of \mathcal{S} and the zero element $\varepsilon_{\mathcal{X}}$ of \mathcal{X} , when there will be no risk of confusion. We will also use concatenation to denote the product of \mathcal{S} , so that (11a) will be rewritten as $(\lambda\mu)x = \lambda(\mu x)$. When (\mathcal{S}, \oplus) is idempotent, (\mathcal{X}, \oplus) is idempotent (indeed, it follows from (11b) and (11c) that $x = ex = (e \oplus e)x = ex \oplus ex = x \oplus x$). A *subsemimodule* of \mathcal{X} is a subset $\mathcal{Z} \subset \mathcal{X}$ such that $\lambda x \oplus \mu y \in \mathcal{Z}$, for all $x, y \in \mathcal{Z}$ and $\lambda, \mu \in \mathcal{S}$. We will consider subsemimodules of the *free semimodule* \mathcal{S}^n , which is the set of n -dimensional vectors over \mathcal{S} , equipped with the internal law $(x \oplus y)_i = x_i \oplus y_i$ and the left action $(\lambda x)_i = \lambda \otimes x_i$. If $G \subset \mathcal{S}^n$, we will denote by $\text{span } G$ the subsemimodule of \mathcal{S}^n generated by G , i.e. the set of all $x \in \mathcal{S}^n$ for which there exists a finite number of elements u^1, \dots, u^k of G and a finite number of scalars $\lambda_1, \dots, \lambda_k \in \mathcal{S}$, such that $x = \bigoplus_{i=1}^k \lambda_i u^i$.

Definition 3.1 (Rational semimodules). A subsemimodule $\mathcal{X} \subset \mathcal{S}^n$ is *rational* if it has a generating family which is a rational subset of the monoid (\mathcal{S}^n, \otimes) .

We now show that rational semimodules are closed under natural algebraic operations. We begin by a simple general property.

Theorem 3.2. *Let \mathcal{S} be an arbitrary semiring. Let $\mathcal{X}, \mathcal{Y} \subset \mathcal{S}^n$ and $\mathcal{Z} \subset \mathcal{S}^p$ be rational semimodules. Then $\mathcal{X} \oplus \mathcal{Y}$ and $\mathcal{X} \times \mathcal{Z}$ are rational semimodules.*

Proof. Let $\mathcal{X} = \text{span } B$, $\mathcal{Y} = \text{span } C$ and $\mathcal{Z} = \text{span } D$, where $B, C \subset \mathcal{S}^n$ and $D \subset \mathcal{S}^p$ are rational sets. As $\mathcal{X} \oplus \mathcal{Y} = \text{span } (B \cup C)$, it follows that $\mathcal{X} \oplus \mathcal{Y}$ is a rational semimodule because $B \cup C$ is a rational set of the monoid (\mathcal{S}^n, \otimes) . Let us denote by ε_k , for $k \in \mathbb{N}$, the neutral element for addition in the commutative monoid (\mathcal{S}^k, \oplus) and let us define the sets

$$\tilde{B} = \left\{ \begin{pmatrix} x \\ \varepsilon_p \end{pmatrix} \mid x \in B \right\} \text{ and } \hat{D} = \left\{ \begin{pmatrix} \varepsilon_n \\ z \end{pmatrix} \mid z \in D \right\}.$$

Since B and D are rational sets, \tilde{B} and \hat{D} are rational sets of the monoid $(\mathcal{S}^{n+p}, \otimes)$. Then, as $\mathcal{X} \times \mathcal{Y} = \text{span } (\tilde{B} \cup \hat{D})$, it follows that $\mathcal{X} \times \mathcal{Y}$ is a rational semimodule. \square

We will need the following analogue of Caratheodory theorem, which was already stated in [Gau98]. (The classical Caratheodory theorem, see e.g. [Sch88, Cor. 7.1i], states that if a vector x in \mathbb{R}^n is a positive linear combination of vectors of a finite subset $G \subset \mathbb{R}^n$, x can be written as a positive linear combinations of at most n vectors of G).

Proposition 3.3 (Max-Plus Caratheodory Theorem). *Let \mathcal{S} be an idempotent semiring whose natural order is a total order. If $G \subset \mathcal{S}^n$, and if $x \in \text{span}(G)$, then there is a subset B of G , of cardinality at most n , such that $x \in \text{span}(B)$.*

Proof. If $x \in \text{span } G$, we can find $u^1, \dots, u^k \in G, \lambda_1, \dots, \lambda_k \in \mathcal{S}$ such that $x = \bigoplus_{1 \leq i \leq k} \lambda_i u^i$. For all $1 \leq j \leq n$, we define $I(j) = \{i \mid 1 \leq i \leq k, x_j = \lambda_i u_j^i\}$. Since the natural order of \mathcal{S} is a total order, all the $I(j)$ are non-empty. Choosing exactly one element i_j in $I(j)$, we obtain a family u^{i_1}, \dots, u^{i_n} such that $x = \lambda_{i_1} u^{i_1} \oplus \dots \oplus \lambda_{i_n} u^{i_n}$ (It may be the case that $i_j = i_k$ for some $j \neq k$. In such cases the cardinality of B is less than n .) \square

Theorem 3.4. *Let \mathcal{S} be an idempotent commutative semiring which satisfies the Presburger property and whose natural order is a total order. Then, for a subset \mathcal{X} of \mathcal{S}^n the following statements are equivalent.*

1. \mathcal{X} is a rational semimodule.
2. \mathcal{X} is a semimodule and a rational subset of the monoid (\mathcal{S}^n, \otimes) .

Proof. Trivially, (2) implies (1) because \mathcal{X} is generated by \mathcal{X} . Suppose now that \mathcal{X} is a rational semimodule and let $G \subset \mathcal{S}^n$ be a rational set such that $\mathcal{X} = \text{span } G$. Let P be a formula of the first-order logic of $(\mathcal{S}, e, \otimes, \preceq)$, that defines G . The Max-Plus Caratheodory Theorem implies that: $x \in \mathcal{X}$ if and only if

$$(\exists u^1 \in \mathcal{S}^n), \dots, (\exists u^n \in \mathcal{S}^n), (\exists \lambda_1 \in \mathcal{S}), \dots, (\exists \lambda_n \in \mathcal{S}),$$

$$\left(P(u^1) \wedge \dots \wedge P(u^n) \wedge x = \bigoplus_{i=1}^n \lambda_i u^i \right).$$

Since the last formula belongs to the first-order logic of $(\mathcal{S}, e, \otimes, \preceq)$, we obtain that \mathcal{X} is a rational set of the commutative monoid (\mathcal{S}^n, \otimes) \square

If \mathcal{X} and \mathcal{Y} are two semimodules, we denote by $\text{Hom}(\mathcal{X}, \mathcal{Y})$ the set of *linear maps*, i.e., of semimodule morphisms, from \mathcal{X} to \mathcal{Y} . A linear map $\mathcal{S}^n \rightarrow \mathcal{S}^p$ can be represented uniquely in matrix form, $x \mapsto Ax$, $(Ax)_i = \bigoplus_{1 \leq j \leq n} A_{ij} x_j$, where $A = (A_{ij}) \in \mathcal{S}^{n \times p}$.

Theorem 3.5 (Closure theorem). *Let \mathcal{S} be an idempotent commutative semiring which satisfies the Presburger property and whose natural order is a total order. Let $\mathcal{X}, \mathcal{Y} \subset \mathcal{S}^n$, $\mathcal{Z} \subset \mathcal{S}^p$, $\mathcal{G} \subset \mathcal{S}^{n+p}$ and $\mathcal{W} \subset (\mathcal{S}^n)^2$ be rational semimodules, and let $A \in \text{Hom}(\mathcal{S}^n, \mathcal{S}^p)$. Then the following sets all are rational semimodules.*

1. $\mathcal{X} \cap \mathcal{Y}$,
2. $\mathcal{X}\mathcal{G} = \{v \in \mathcal{S}^p \mid \exists x \in \mathcal{X}, (x, v) \in \mathcal{G}\}$ and $\mathcal{G}\mathcal{Z} = \{u \in \mathcal{S}^n \mid \exists z \in \mathcal{Z}, (u, z) \in \mathcal{G}\}$,
3. $A\mathcal{X} = \{Ax \mid x \in \mathcal{X}\}$,
4. $A^{-1}\mathcal{Z} = \{x \in \mathcal{S}^n \mid Ax \in \mathcal{Z}\}$,
5. $\mathcal{X} \oplus \mathcal{Y} = \{u \in \mathcal{S}^n \mid \exists y \in \mathcal{Y}, u \oplus y \in \mathcal{X}\}$,
6. $\mathcal{W}^\perp = \{x \in \mathcal{S}^n \mid a \cdot x = b \cdot x, \forall (a, b) \in \mathcal{W}\}$, where $a \cdot x = \bigoplus_{1 \leq i \leq n} a_i x_i$,

$$7. \mathcal{X}^\top = \{(a, b) \in (\mathcal{S}^n)^2 \mid a \cdot x = b \cdot x, \forall x \in \mathcal{X}\}.$$

Proof. 1. Since \mathcal{X} and \mathcal{Y} are rational semimodules, we know that they are rational sets (by Theorem 3.4). As the intersection of rational sets of a commutative monoid is a rational set (see [ES69]), we have that $\mathcal{X} \cap \mathcal{Y}$ is a rational set and therefore a rational semimodule.

2. By symmetry, we only consider the case of $\mathcal{X}\mathcal{G}$. Since $\mathcal{G} \subset \mathcal{S}^{n+p}$ and $\mathcal{X} \subset \mathcal{S}^n$ are rational semimodules, we know that they are rational sets of $(\mathcal{S}^{n+p}, \otimes)$ and (\mathcal{S}^n, \otimes) respectively (by Theorem 3.4). Let P and Q be Presburger formulas of $(\mathcal{S}, e, \otimes, \preceq)$, defining \mathcal{G} and \mathcal{X} respectively. Then as

$$v \in \mathcal{X}\mathcal{G} \text{ if and only if } (\exists x \in \mathcal{S}^n)(Q(x) \wedge P(x, v)),$$

it follows that $\mathcal{X}\mathcal{G}$, which is defined by a Presburger formula of $(\mathcal{S}, e, \otimes, \preceq)$, is a rational set. By Theorem 3.4, it is a rational semimodule.

3. Let us define $\mathcal{G} = \{(u, Au) \mid u \in \mathcal{S}^n\}$. Since \mathcal{G} is finitely generated, \mathcal{G} is a rational semimodule, and $A\mathcal{X} = \mathcal{X}\mathcal{G}$ is a rational semimodule.

4. Taking again $\mathcal{G} = \{(u, Au) \mid u \in \mathcal{S}^n\}$, we have $A^{-1}\mathcal{Z} = \mathcal{G}\mathcal{Z}$. Hence, $A^{-1}\mathcal{Z}$ is a rational semimodule.

5. Let us define $\mathcal{G} = \{(u, y, x) \in (\mathcal{S}^n)^3 \mid x = u \oplus y\}$. Then \mathcal{G} , which is the direct image of $(\mathcal{S}^n)^2$ by a linear map, is finitely generated, and a fortiori, rational. Thus, $\mathcal{X} \ominus \mathcal{Y} = \{u \in \mathcal{S}^n \mid \exists x \in \mathcal{X}, \exists y \in \mathcal{Y}, x = u \oplus y\} = \{u \in \mathcal{S}^n \mid \exists x \in \mathcal{X}, \exists y \in \mathcal{Y}, (u, y, x) \in \mathcal{G}\} = \mathcal{G}(\mathcal{Y} \times \mathcal{X})$ is a rational semimodule.

6. As $\mathcal{W} \subset (\mathcal{S}^n)^2$ is a rational semimodule, we know (by Theorem 3.4) that it is a rational set. Let $P(u_1, \dots, u_n, v_1, \dots, v_n)$ be a Presburger formula of $(\mathcal{S}, e, \otimes, \preceq)$ defining \mathcal{W} . Then $(x_1, \dots, x_n) \in \mathcal{W}^\perp$ if and only if

$$\begin{aligned} \forall u_1 \in \mathcal{S}, \dots, \forall u_n \in \mathcal{S}, \forall v_1 \in \mathcal{S}, \dots, \forall v_n \in \mathcal{S} \\ (P(u_1, \dots, u_n, v_1, \dots, v_n) \Rightarrow \bigoplus_{i=1}^n x_i u_i = \bigoplus_{j=1}^n x_j v_j). \end{aligned}$$

Since this is a Presburger formula of $(\mathcal{S}, e, \otimes, \preceq)$, it follows that \mathcal{W}^\perp is a rational set of (\mathcal{S}^n, \otimes) , and also, by Theorem 3.4, a rational semimodule.

7. Let $P(x_1, \dots, x_n)$ be a Presburger formula of $(\mathcal{S}, e, \otimes, \preceq)$ defining \mathcal{X} . Then we have that $(u, v) \in \mathcal{X}^\top$ if and only if

$$(\forall x_1 \in \mathcal{S}), \dots, (\forall x_n \in \mathcal{S}), (P(x_1, \dots, x_n) \Rightarrow \bigoplus_{i=1}^n u_i x_i = \bigoplus_{j=1}^n v_j x_j) .$$

Arguing as in Statement 6, we conclude that \mathcal{X}^\top is a rational semimodule. \square

Remark 3.6. A motivation for considering the operations \ominus and $\mathcal{Z} \rightarrow A^{-1}\mathcal{Z}$ comes from (A, B) invariant spaces (see [Won85]). If one consider the dynamical system

$$x(k) = Ax(k-1) \oplus Bu(k),$$

where $A \in (\mathbb{Z}_{\max})^{n \times n}$, $B \in (\mathbb{Z}_{\max})^{n \times p}$, $x(k) \in (\mathbb{Z}_{\max})^n$, and $u(k) \in (\mathbb{Z}_{\max})^p$, the set of $x(0)$ for which there exists a control $u(0)$ such that $x(1)$ belongs to a prescribed semimodule \mathcal{X} is $A^{-1}(\mathcal{X} \ominus B)$, where B denotes the semimodule generated by the columns of B . Max-plus (A, B) -invariant spaces are further studied in [Kat].

We shall say that a vector v of a semimodule $\mathcal{X} \subset \mathcal{S}^n$ is *extremal* if $v \notin \text{span}(\mathcal{X} \setminus \text{span}\{v\})$. We denote by $\text{Ext}(\mathcal{X})$ the set of extremal points of \mathcal{X} . The interest in extremal points stems from a theorem due to Moller [Mol88] and Wagneur [Wag91], which states that a finitely generated subsemimodule of $(\mathbb{R}_{\max})^n$ is generated by its extremal vectors.

Theorem 3.7. *Let \mathcal{S} be an idempotent commutative semiring which satisfies the Presburger property and whose natural order is a total order. If $\mathcal{X} \subset \mathcal{S}^n$ is a rational semimodule, then $\text{Ext}(\mathcal{X})$ is a rational set of the monoid (\mathcal{S}^n, \otimes) .*

Proof. Let P be a Presburger formula of $(\mathcal{S}, e, \otimes, \preceq)$ defining \mathcal{X} . The max-plus Caratheodory theorem shows that $v \in \text{span}(\mathcal{X} \setminus \text{span}\{v\})$ is equivalent to

$$\begin{aligned} & (\exists u^1 \in \mathcal{S}^n), \dots, (\exists u^n \in \mathcal{S}^n), (\exists \lambda_1 \in \mathcal{S}), \dots, (\exists \lambda_n \in \mathcal{S}) P(u^1) \wedge \dots \wedge P(u^n) \\ & \wedge (v = \bigoplus_{i=1}^n \lambda_i u^i) \wedge \neg ((\exists \alpha_1 \in \mathcal{S})(u^1 = \alpha_1 v) \vee \dots \vee (\exists \alpha_n \in \mathcal{S})(u^n = \alpha_n v)) \quad . \end{aligned}$$

Since this is a Presburger formula of $(\mathcal{S}, e, \otimes, \preceq)$, it follows that $\mathcal{X} \setminus \text{Ext}(\mathcal{X})$ is a rational set, and therefore $\text{Ext}(\mathcal{X})$ is a rational set. \square

Remark 3.8. We could prove Statement 3 of Theorem 3.5 without using Presburger's arithmetics, as follows. If R is a rational set that generates the semimodule \mathcal{X} , $A\mathcal{X}$ is generated by the set $A(R) = \{Ar \mid r \in R\}$. One can show directly, using the fact that a max-plus linear map is piecewise affine with integer slopes, that $A(R)$ is rational.

Remark 3.9. A difficulty, in looking for more direct proofs of Statements 1,2,4–7 of Theorem 3.5, is the relative absence of knowledge of the minimal set of generators of a semimodule defined by natural algebraic operations. This difficulty persists even in the case of finitely generated semimodules. For instance, the only known algorithm (see [BH84], [Gau92, III,1.1.4] or [GP97, Th. 8]) to compute a generating family of the set of solutions of the max-plus linear system $Ax = Bx$, where A, B are $n \times p$ matrices, has an a priori doubly exponential execution time, and tells little about the geometry of extremal points. (However, the doubly exponential bound is pessimistic, the average case is better in practice, and finding only one solution can be done more efficiently by computing sub-fixed point of min-max functions, see [WB96, GP97, BCG99] and [GG98, CTGG99] for fixed point algorithms for min-max functions.)

4 Examples and Counter Examples

4.1 Reachable and Observable Spaces of Max-Plus Linear Discrete Event Systems

Let us consider the max-plus linear system:

$$x(k) = Ax(k-1) \oplus Bu(k), \quad (12a)$$

$$y(k) = Cx(k), \quad (12b)$$

$$x(0) = \xi. \quad (12c)$$

where $A \in (\mathbb{Z}_{\max})^{n \times n}$, $B \in (\mathbb{Z}_{\max})^{n \times p}$, $C \in (\mathbb{Z}_{\max})^{q \times n}$, $\xi \in (\mathbb{Z}_{\max})^n$, and $u(k) \in (\mathbb{Z}_{\max})^p$, $k = 1, 2, \dots$ is a sequence of control vectors. We call *reachable space* in time k , and denote by \mathcal{R}_k , the set of states $x(k)$ reachable from the initial state $x(0) = \xi$. We also define the *reachable space* in arbitrary time, \mathcal{R}_ω , which is the union of the \mathcal{R}_k . (We shall sometimes write $\mathcal{R}_k(A, B)$ or $\mathcal{R}_\omega(A, B)$ to emphasize the dependence in A, B .) Introducing the *reachability matrices*

$$\mathbf{R}_k = (B, AB, \dots, A^{k-1}B), \quad \mathbf{R}_\omega = (B, AB, A^2B \dots),$$

we characterize \mathcal{R}_k (resp. \mathcal{R}_ω) as the semimodule generated by the columns of the matrix \mathbf{R}_k (resp. \mathbf{R}_ω). Identifying matrices with operators, we will write $\mathcal{R}_k = \text{Im } \mathbf{R}_k$, and $\mathcal{R}_\omega = \text{Im } \mathbf{R}_\omega$.

The definition of rational semimodules is motivated by the following result:

Theorem 4.1. *Reachable spaces are rational semimodules, i.e. if $A \in (\mathbb{Z}_{\max})^{n \times n}$ and $B \in (\mathbb{Z}_{\max})^{n \times p}$, then $\mathcal{R}_\omega = \text{Im } \mathbf{R}_\omega$ is a rational semimodule.*

The proof of Theorem 4.1 relies on the following cyclicity theorem for reducible max-plus matrices, which is taken from [Gau92, VI,1.1.10].

Theorem 4.2. *Let $A \in (\mathbb{R}_{\max})^{n \times n}$. There are positive integers c, N , such that for all $1 \leq i, j \leq n$, there are scalars $\lambda_0, \dots, \lambda_{c-1}$ (depending on i, j) such that for all $0 \leq l \leq c-1$,*

$$\forall n \geq N, \quad (A^{n+l+c})_{ij} = \lambda_l (A^{n+l})_{ij}. \quad (13)$$

This cyclicity theorem follows readily from the characterization of max-plus rational series in one variable as merge of ultimately rational series, see [Mol88], [Gau92, VI,1.1.8], [KR94], and the discussions in [Gau94, GP97].

Proof of Theorem 4.1. Theorem 4.2 implies that $\{A^0, A^1, A^2, \dots\}$ is a rational subset of $((\mathbb{Z} \cup \{-\infty\})^{n \times n}, +)$, and therefore, $\mathcal{X} = \text{span} \{A^0, A^1, A^2, \dots\}$ is a rational subsemimodule of $(\mathbb{Z}_{\max})^{n \times n}$. Since $\mathcal{R}_\omega(A, B)$ is the sum of the reachability spaces $\mathcal{R}_\omega(A, B_{\cdot, i})$ associated to the different columns $B_{\cdot, i}$ of B , for $1 \leq i \leq p$, and since the sum of rational semimodules is rational (cf. Theorem 3.2), it is enough to consider the case when B has only one column. Then, \mathcal{R}_ω is the direct image of \mathcal{X} by the linear map $(\mathbb{Z}_{\max})^{n \times n} \rightarrow (\mathbb{Z}_{\max})^{n \times 1}$, $X \mapsto XB$, and it follows from Statement 3 of Theorem 3.5 that \mathcal{R}_ω is rational. \square

Let $\xi, \xi' \in (\mathbb{Z}_{\max})^n$, and consider two trajectories of the dynamical system (12),

$$\{(x(k), y(k))\}_{k \geq 0}, \quad \text{and} \quad \{(x'(k), y'(k))\}_{k \geq 0},$$

corresponding to the initial conditions $x(0) = \xi$, $x'(0) = \xi'$, the zero control $u(k) \equiv \varepsilon$ being applied in both cases. We call *observable congruence* in time $k \geq 1$, and denote by \mathcal{O}_k , the congruence over $(\mathbb{Z}_{\max})^n$ defined by

$$(\xi, \xi') \in \mathcal{O}_k \iff y(l) = y'(l), \quad \forall 0 \leq l \leq k-1,$$

and the *observable congruence* (in arbitrary time) \mathcal{O}_ω is defined as the intersection of the congruences \mathcal{O}_k , $k \geq 1$. By congruence, we mean an equivalence relation on $(\mathbb{Z}_{\max})^n$ compatible with the semimodule structure of $(\mathbb{Z}_{\max})^n$. In particular, \mathcal{O}_k and \mathcal{O}_ω are subsemimodules of $((\mathbb{Z}_{\max})^n)^2$. Introducing the *observability matrices*

$$\mathbf{O}_k = \begin{pmatrix} C \\ CA \\ \vdots \\ CA^{k-1} \end{pmatrix}, \quad \mathbf{O}_\omega = \begin{pmatrix} C \\ CA \\ CA^2 \\ \vdots \end{pmatrix},$$

we characterize \mathcal{O}_k (resp. \mathcal{O}_ω) as the right kernel $\text{Ker } \mathbf{O}_k$ (resp. $\text{Ker } \mathbf{O}_\omega$) of \mathbf{O}_k (resp. \mathbf{O}_ω), that is:

$$(\xi, \xi') \in \mathcal{O}_k \iff \mathbf{O}_k \xi = \mathbf{O}_k \xi', \quad (\xi, \xi') \in \mathcal{O}_\omega \iff \mathbf{O}_\omega \xi = \mathbf{O}_\omega \xi'.$$

See [CGQ99] for more background on max-plus reachability spaces and observable congruences. We have the following dual version of Theorem 4.1:

Theorem 4.3. *Observable congruences are rational, i.e. if $A \in (\mathbb{Z}_{\max})^{n \times n}$, $C \in (\mathbb{Z}_{\max})^{q \times n}$, then $\mathcal{O}_\omega = \text{Ker } \mathbf{O}_\omega$ is a rational subsemimodule of $((\mathbb{Z}_{\max})^n)^2$.*

Proof. By Theorem 4.1, the semimodule \mathcal{Z} generated by the rows of the observability matrix \mathbf{O}_ω , which can be identified to the reachable space $\mathcal{R}_\omega(A^T, B^T)$, is rational. Since $\mathcal{O}_\omega = \mathcal{Z}^\top$, Statement 7 of Theorem 3.5 shows that \mathcal{O}_ω is rational. \square

4.2 Example of reachable space and observable congruence

Consider

$$A = \begin{pmatrix} 1 & -\infty & -\infty \\ 5 & 2 & -\infty \\ -\infty & 6 & 3 \end{pmatrix}, \quad B = \begin{pmatrix} 0 \\ -\infty \\ -\infty \end{pmatrix}. \quad (14)$$

Then $\mathcal{R}_\omega = \text{Im } \mathbf{R}_\omega$ where

$$\mathbf{R}_\omega = \begin{pmatrix} 0 & 1 & 2 & 3 & 4 & 5 & 6 & \dots \\ -\infty & 5 & 7 & 9 & 11 & 13 & 15 & \dots \\ -\infty & -\infty & 11 & 14 & 17 & 20 & 23 & \dots \end{pmatrix}. \quad (15)$$

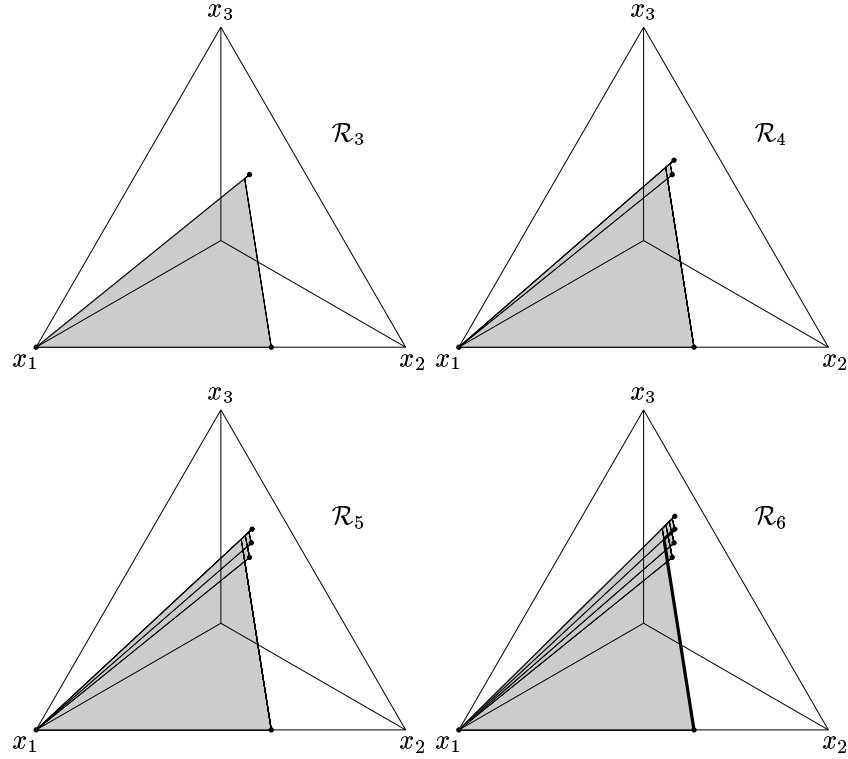

Figure 1: Exponential representation of the reachable spaces $\mathcal{R}_3, \mathcal{R}_4, \mathcal{R}_5, \mathcal{R}_6$ for the (A, B) pair given by (14)

Obviously \mathcal{R}_ω is a rational semimodule because the set of columns of R_ω can be written as $U \cup (\{v\} + \{w\}^*)$, with

$$U = \left\{ \begin{pmatrix} 0 \\ -\infty \\ -\infty \end{pmatrix}, \begin{pmatrix} 1 \\ 5 \\ -\infty \end{pmatrix} \right\}, \quad v = \begin{pmatrix} 2 \\ 7 \\ 11 \end{pmatrix}, \quad w = \begin{pmatrix} 1 \\ 2 \\ 3 \end{pmatrix} \quad (16)$$

The semimodules $\mathcal{R}_3, \mathcal{R}_4, \mathcal{R}_5, \mathcal{R}_6$ are shown on Figure 1.

To represent semimodules which contain vectors with $-\infty$ coordinates, we use the following projection. Let β denote a positive parameter, and let us chose a triangle in the plane. We represent a point $x \in (\mathbb{R} \cup \{-\infty\})^3$ by the point $\pi(x)$ of the triangle, which is the barycenter of the vertices of the triangle with respective weights $\exp(\beta x_1)$, $\exp(\beta x_2)$, $\exp(\beta x_3)$. We shall refer to this projection as the *exponential projection* in the sequel. The exponential projection has the property that if two points x and y are proportional in the

max-plus sense, that is, if $x_i = \lambda + y_i$ for some $\lambda \in \mathbb{R}$, then, $\pi(x) = \pi(y)$. Therefore, representing the image of a semimodule $\mathcal{X} \subset (\mathbb{R}_{\max})^3$ (or $\mathcal{X} \subset (\mathbb{Z}_{\max})^3$) by π gives a faithful image of \mathcal{X} . Such drawings represent in fact the max-plus two-dimensional *projective space*, which is the quotient of $(\mathbb{R}_{\max})^3$ by the parallelism relation $x \sim y \iff x = \lambda + y$ for some $\lambda \in \mathbb{R}$. The max-plus projective space appeared in the work of several authors, see [Kol92, Gau95, Mai95, Gau98].

In Figure 1, the generators of the semimodules $\mathcal{R}_3, \mathcal{R}_4, \mathcal{R}_5, \mathcal{R}_6$, that is, the columns of the matrices $\mathbf{R}_3, \mathbf{R}_4, \mathbf{R}_5, \mathbf{R}_6$, are represented by bold points. For any two generators, we have represented the max-plus plane generated by these two generators (we call *plane* a semimodule generated by two nonproportional vectors). The projection π sends in general a plane to a broken segment. For instance, the bold broken segment on the fourth picture of Figure 1 represents the max-plus plane generated by the second and fifth columns of \mathbf{R}_6 .

It should be graphically clear from Figure 1 that the generators are extremal, that the semimodules $\mathcal{R}_k, k = 0, 1, 2, 3, \dots$ form an infinite ascending sequence (this illustrates the fact that the semimodule $(\mathbb{Z}_{\max})^3$ is not Noetherian), and that \mathcal{R}_ω is not finitely generated. One can check mechanically all these facts by appealing to residuation theory, which allows us to compute the extremal vectors of semimodules, see [BCOQ92],[But94] and [GP97] for more details. Let us also mention that the computations of this example have been checked using the max-plus toolbox of scilab, see [Plu98].

We can visualize, on the drawings of Figure 1, both the \mathbb{R}_{\max} semimodule and the \mathbb{Z}_{\max} semimodule generated by the columns of the matrices \mathbf{R}_k . The gray zone represent an \mathbb{R}_{\max} semimodule. The corresponding \mathbb{Z}_{\max} semimodule is an “integer lattice” inscribed in the real semimodule, that for readability of the figure, we do not have represented.

To see graphically that the semimodule \mathcal{R}_ω is rational, it is convenient to use another representation, in which every *finite* point of \mathcal{R}_ω is projected orthogonally to the main diagonal of \mathbb{R}^3 : again, two vectors $x, y \in \mathbb{R}^3$ which are proportional in the max-plus sense, are sent to the same point. Using this projection, the semimodule \mathcal{R}_{12} is represented on Figure 2. The rationality of \mathcal{R}_ω can be visualized on this figure: the set of finite generators of \mathcal{R}_ω , which is given by $\{v\} + \{w\}^*$, where v, w are as in (16), is precisely the discrete half line of bold points.

Let us now represent an observability congruence. We consider the transposed dynamical system with new observation matrix $C = B^T$ and new dynamics A^T . Then, the observability matrix is $\mathbf{O}_\omega(A^T, B^T) = (\mathbf{R}_\omega(A, B))^T$, that is, the transpose of the matrix computed in (15). The corresponding observable congruence \mathcal{O}_ω is depicted in Figure 3, using the technique of [CGQ99, § 4.3]. We know by Theorem 4.3 that this is a rational congruence. The gray region of Figure 3 represents the semimodule over the min-plus semiring $\mathbb{Z}_{\min} = (\mathbb{Z} \cup \{+\infty\}, \min, +)$ generated by the opposite of the rows of \mathbf{O}_ω (the min-plus generators are represented by bold points): we know from [CGQ99] that equivalence classes for \mathcal{O}_ω of points of the interior of this semimodule are singletons. Other equivalence classes are half-lines, as shown on the figure.

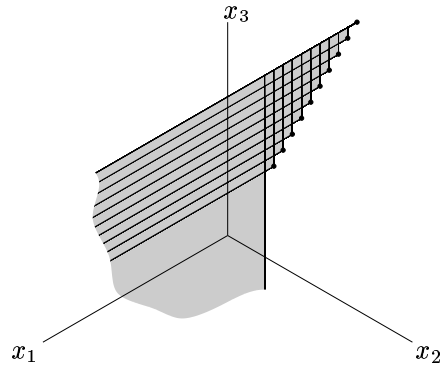

Figure 2: Orthogonal projection of the reachable space \mathcal{R}_{12} for the (A, B) pair of (14)

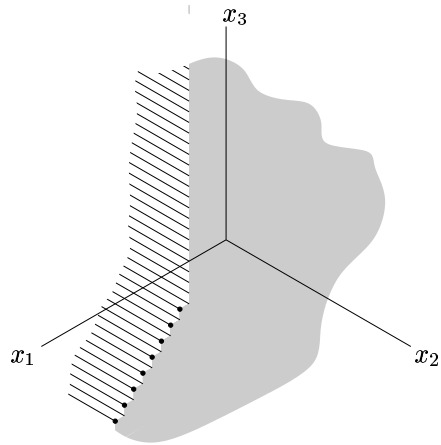

Figure 3: Observable congruence associated to (A^T, B^T)

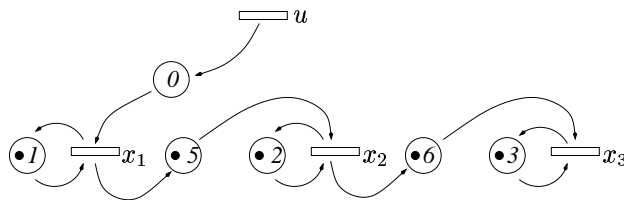

Figure 4: A timed event graph representing three machines in tandem

4.3 Manufacturing system interpretation

We next interpret the previous computations in terms of discrete event systems. The dynamical system (12),(14) can be seen as the dater representation of the timed event graph of Figure 4 (we refer the reader to [BCOQ92] for more details on the modeling of timed event graphs).

This graph represent three machines in tandem, with respective processing times 1, 2, 3. The first machine is fed by a source u , and sends its output to a second machine, with a transportation delay of 5. The second machine sends its output to a third machine, with a transportation delay of 6. We associate to each transition a dater function $\mathbb{N} \rightarrow \mathbb{R}_{\max}$: for instance, $u(k)$ gives the date of the k -th firing of the transition labeled u , i.e. $u(k)$ is the arrival time of the k -th part, $x_3(k)$ gives the date at which the third machine initiates its k -th task, etc. The reachable spaces \mathcal{R}_k , which were depicted in Figure 2, determine the possible values of the daters $x_i(k)$, $i = 1, \dots, 3$. The assumption that $x(0) = \varepsilon$ means that the machines are ready to operate much before the first part arrives from the source, so that only the $u \mapsto x$ relation is considered.

Practically relevant quantities are the differences $x_i - x_j$: for instance, $x_2(k) - x_1(k-1)$ gives the sojourn time of the $(k-1)$ -th part in the storage resource between the first and the second machine. The timed event graph of Figure 4 is an example of instable system, since the second machine is slower than the first machine, parts may accumulate infinitely in the intermediate storage resource. This is reflected by the unboundedness of the orthogonal representation of the reachable semimodule, in Figure 2. For instance, one can obtain for the trajectory $x(k)$ the sequence of columns of the matrix \mathcal{R}_ω by taking $u(k) = k$.

The finite control sequence which leads $x(0) = \varepsilon$ to $x(k) = z$ can be computed by solving the system $R_k U_k = z$, where $U_k = (u(1), \dots, u(k))^T$. This system can be solved in polynomial time using residuation theory, see [BCOQ92] (or [But94] for a more combinatorial presentation). We did not address the difficulty that the finite control sequence U_k which leads to a given point of the reachable space need not be physically admissible, because dater functions must be *nondecreasing*. Nondecreasing controls can be modeled at the price of adding one variable: if u is an arbitrary control sequence, the max-plus linear dynamical system $v(k) = v(k-1) \oplus u(k)$ computes the nondecreasing hull v of u , and therefore v represents an arbitrary nondecreasing control sequence.

4.4 Rational semimodules over \mathbb{R}_{\max} need not be stable by direct image

When $\mathcal{S} = \mathbb{R}_{\max}$, the set of rational semimodules has no nice closure properties. We first show that the direct image of a rational set by a linear map need not be a rational set. Let α denote a positive irrational number, and consider the two vectors

$$u = \begin{pmatrix} 1 \\ -\alpha \end{pmatrix}, \quad v = -\alpha^{-1}u = \begin{pmatrix} -\alpha^{-1} \\ 1 \end{pmatrix},$$

together with $R = \{u, v\}^* \setminus \{0\}$. Since $R = \{u, v\} + \{u, v\}^*$, R is rational. Now, let $A = (0, 0) \in (\mathbb{R}_{\max})^{1 \times 2}$. We have that:

$$\begin{aligned} A(R) &= \{\max(h_1 - \alpha^{-1}h_2, h_2 - \alpha h_1) \mid h_1, h_2 \in \mathbb{N}, h_1 + h_2 \geq 1\} \\ &= \{\max(-\alpha^{-1}t, t) \mid t = h_2 - \alpha h_1, h_1, h_2 \in \mathbb{N}, h_1 + h_2 \geq 1\}. \end{aligned} \quad (17)$$

We claim that the set $A(R)$ is not rational. Indeed, let us assume by contradiction that $A(R)$ is semilinear, i.e., that $A(R) = \cup_{1 \leq i \leq k} (\{a_i\} + U_i)$, where the a_i are elements of $\mathbb{R} \cup \{-\infty\}$ and the U_i are finite subsets of $\mathbb{R} \cup \{-\infty\}$. We first remark that since $-\infty \notin A(R)$, $a_i \neq -\infty$, and $-\infty \notin U_i$, for all $1 \leq i \leq k$. Using this remark, we now deduce that the elements of U_i must be nonnegative: otherwise, $A(R)$ would not be bounded from below, and this would contradict the fact that $\inf A(R) = 0$ which follows from (17). Since all the elements of U_i are nonnegative, $A(R)$ has a minimal element (namely $\min_{1 \leq i \leq k} a_i$), and this contradicts (17) because α is an irrational number.

We next show that when $\mathcal{S} = \mathbb{R}_{\max}$, the image of a rational semimodule by a linear map need not be a rational semimodule. Consider

$$u = \begin{pmatrix} 1 \\ -\alpha \\ 0 \end{pmatrix}, \quad v = -\alpha^{-1}u = \begin{pmatrix} -\alpha^{-1} \\ 1 \\ 0 \end{pmatrix},$$

$$R = \{u, v\}^* \setminus \{0\}, \quad A = \begin{pmatrix} 0 & 0 & -\infty \\ -\infty & -\infty & 0 \end{pmatrix},$$

and $\mathcal{X} = \text{span } R$. Then $A(\mathcal{X}) = \text{span } A(R)$ is spanned by the vectors

$$\begin{pmatrix} \max(h_1 - \alpha^{-1}h_2, h_2 - \alpha h_1) \\ 0 \end{pmatrix}, \quad \text{for } h_1, h_2 \in \mathbb{N}, h_1 + h_2 \geq 1.$$

To make $A(\mathcal{X})$ more explicit, let us observe that for all real numbers γ, δ ,

$$\text{span} \begin{pmatrix} \gamma & \delta \\ 0 & 0 \end{pmatrix} = \left\{ \begin{pmatrix} x_1 \\ x_2 \end{pmatrix} \in \mathbb{R}^2 \mid \min(\gamma, \delta) + x_2 \leq x_1 \leq x_2 + \max(\gamma, \delta) \right\} \cup \left\{ \begin{pmatrix} -\infty \\ -\infty \end{pmatrix} \right\}. \quad (18)$$

It follows from (18) that

$$A(\mathcal{X}) = \left\{ \begin{pmatrix} x_1 \\ x_2 \end{pmatrix} \in \mathbb{R}^2 \mid x_1 > x_2 \right\} \cup \left\{ \begin{pmatrix} -\infty \\ -\infty \end{pmatrix} \right\} . \quad (19)$$

Now, a straightforward variant of the proof of the irrationality of $A(R)$ that we gave above shows that $A(\mathcal{X})$ is not a rational semimodule, for, if $A(\mathcal{X})$ was spanned by a semilinear set, the quantity $x_1 - x_2$ would attain its infimum when $x \in A(\mathcal{X}) \cap \mathbb{R}^2$, whereas (19) shows that this infimum, which is equal to 0, is not attained.

Thus, when $S = \mathbb{R}_{\max}$, the direct image of a rational semimodule by a linear map need not be rational.

4.5 Noncommutative reachable spaces need not be rational

Let us consider now a time varying version of the max-plus linear system (12), in which (12a) is replaced by

$$x(k) = A(k)x(k-1) \oplus Bu(k) , \quad (20)$$

where the matrix $A(k)$ can take any value in a finite set $\{A_1, \dots, A_r\} \subset (\mathbb{Z}_{\max})^{n \times n}$.

In order to characterize the reachable space and to show that it need not be rational, it is useful to introduce some classical automata theoretical notation (see [BR88]). Let $\Sigma = \{a_1, \dots, a_r\}$ denote an alphabet of r letters. Recall that the free monoid Σ^* is the set of finite words on Σ , equipped with concatenation product. Let $\mu : \Sigma^* \rightarrow (\mathbb{Z}_{\max})^{n \times n}$ denote the unique morphism of monoids which sends a_i to A_i . The *reachable space* \mathcal{R} , that is, the set of all possible values of $x(k) \in (\mathbb{Z}_{\max})^n$, the control sequence u and the time k being chosen arbitrarily, starting from $x(0) = \varepsilon$, is given by:

$$\mathcal{R} = \text{span}(\mu(\Sigma^*)B) = \text{span}\{\mu(w)B \mid w \in \Sigma^*\} .$$

We next show that $\mu(\Sigma^*)$, and a fortiori $\{\mu(w)B \mid w \in \Sigma^*\}$, need not be a rational subset of $(\mathbb{Z}_{\max})^{n \times n}$, and that the reachable space \mathcal{R} need not be rational.

Our counter-example relies on a remarkable construction of I. Simon [Sim90]. To minimize changes by comparison to [Sim90], we will work in the semiring \mathbb{Z}_{\min} , rather than in \mathbb{Z}_{\max} . All the results that follows have of course equivalent versions in \mathbb{Z}_{\max} .

Let $\nu : \{a_1, a_2\}^* \rightarrow (\mathbb{Z}_{\min})^{4 \times 4}$ denote the unique morphism such that:

$$\nu(a_1) = \begin{pmatrix} 0 & \infty & \infty & \infty \\ \infty & 1 & 1 & \infty \\ \infty & \infty & \infty & \infty \\ \infty & \infty & \infty & 0 \end{pmatrix} \quad \text{and} \quad \nu(a_2) = \begin{pmatrix} 1 & 1 & \infty & \infty \\ \infty & \infty & \infty & 0 \\ \infty & \infty & \infty & 0 \\ \infty & \infty & \infty & 0 \end{pmatrix} ,$$

and consider the function $s : \Sigma^* \rightarrow \mathbb{Z}_{\min}, w \mapsto s(w)$,

$$s(w) = \alpha \mu(w) \beta \quad \text{where } \alpha = (0 \ \infty \ \infty \ \infty) \text{ and } \beta = (0 \ \infty \ \infty \ 0)^T . \quad (21)$$

Simon [Sim90] shows that

$$\min\{|w| \mid s(w) \geq n\} = \sum_{k=1}^2 \binom{n}{k} = \frac{n^2 + n}{2}, \quad \forall n \in \mathbb{N}, \quad (22)$$

where $|w|$ denotes the length of the word w . In essence, (22) means that $s(w)$ takes values of order $\sqrt{|w|}$ when $|w| \rightarrow \infty$. We will use this property to build an irrational reachable space \mathcal{R} .

Let

$$D = \begin{pmatrix} -1 & +\infty \\ +\infty & 0 \end{pmatrix}$$

and consider the unique morphism $\mu : \{a_1, a_2\}^* \rightarrow (\mathbb{Z}_{\min})^{6 \times 6}$,

$$\mu(a_1) = \text{diag}(\nu(a_1), D), \quad \mu(a_2) = \text{diag}(\nu(a_2), D), \quad (23)$$

where $\text{diag}(F, G)$ denote the matrix with diagonal blocks F and G and $+\infty$ elsewhere. The following proposition shows that the reachable space \mathcal{R} obtained by taking B to be the identity matrix, and μ as above, is irrational.

Proposition 4.4. *Let μ be defined by (23). Then, $\text{span } \mu(\{a_1, a_2\}^*)$ is not a rational sub-semimodule of $(\mathbb{Z}_{\min})^{6 \times 6}$. A fortiori, the semigroup $\mu(\{a_1, a_2\}^*)$ is an irrational subset of $(\mathbb{Z} \cup \{+\infty\})^{6 \times 6}$, $+$.*

Proof. Let C denote the map $(\mathbb{Z}_{\min})^{6 \times 6} \rightarrow (\mathbb{Z}_{\min})^3$, which sends a matrix X to

$$C(X) = (\alpha Y \beta, X_{55}, X_{66}),$$

where Y denote the $\{1, 2, 3, 4\} \times \{1, 2, 3, 4\}$ principal submatrix of X . Using (23) and (21), we get

$$C(\mu(w)) = (s(w), -|w|, 0), \quad \forall w \in \{a_1, a_2\}^*. \quad (24)$$

If $\mathcal{X} = \text{span } \mu(\{a_1, a_2\}^*)$ were rational, $C(\mathcal{X})$ would also be rational, by Theorem 3.5. We have represented $C(\mathcal{X})$ on Figure 5: the irrationality of $C(\mathcal{X})$ is intuitively clear from the figure, since the boundary of the semimodule has a discrete quadratic shape (extremal points are represented by bold points).

However, proving that the figure is correct would require some reworking of the arguments of [Sim90], so we will give a simpler formal argument showing the irrationality of $C(\mathcal{X})$. Let

$$W = \{w \in \{a_1, a_2\}^* \mid s(z) \geq s(w) \implies |z| \geq |w|\}.$$

We claim that

$$\forall w \in W, C(\mu(w)) \text{ is an extremal point of } C(\mathcal{X}). \quad (25)$$

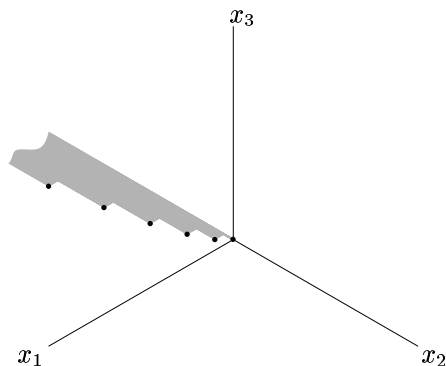

Figure 5: An irrational subsemimodule of $(\mathbb{Z}_{\min})^3$.

Let us first show that Claim (25) implies the irrationality of $C(\mathcal{X})$. Consider

$$E = \{(x_1, x_2) \mid (x_1, x_2, 0) \in \text{Ext}(C(\mathcal{X}))\} . \quad (26)$$

If \mathcal{X} were rational, so would be $C(\mathcal{X})$, and by Theorem 3.7, the set of extremal points $\text{Ext}(C(\mathcal{X}))$ of $C(\mathcal{X})$ would be rational, and so E would be rational.

Now, it follows from the definition of extremal points that for any set G of generators of a semimodule \mathcal{X} ,

$$\text{Ext}(\mathcal{X}) \subset \mathbb{Z} + G = \{\lambda \otimes g \mid \lambda \in \mathbb{Z}, g \in G\} . \quad (27)$$

Combining (27), (26), and (25), and using the fact that the third coordinate of $C(\mu(w))$ is 0 for all $w \in \{a_1, a_2\}^*$, we get that

$$\{(s(w), -|w|) \mid w \in W\} \subset E \subset \{(s(w), -|w|) \mid w \in \{a_1, a_2\}^*\} . \quad (28)$$

Now, for any rational subset R of $(\mathbb{Z}^2, +)$, consider the function:

$$\gamma_R : \mathbb{Z} \rightarrow \mathbb{Z} \cup \{\pm\infty\}, \gamma_R(n) = \sup\{k \in \mathbb{Z} \mid (n, k) \in R\} ,$$

together with its support:

$$\text{supp } \gamma_R = \{n \in \mathbb{Z} \mid \exists k \in \mathbb{Z}, (n, k) \in R\} = \{n \in \mathbb{Z} \mid \gamma_R(n) \neq -\infty\} .$$

It follows from the fact that rational subsets of $(\mathbb{Z}^2, +)$ are semilinear that if R is rational, the restriction of γ_R to its support can be bounded from below by an affine function. But (28), together with (22), so that $\gamma_E(n)$ takes values of order of magnitude $-(n^2 + n)/2$. Therefore, E is irrational, a contradiction.

It remains to show Claim (25). Since several words w of the same length can give the same $s(w)$, the family $\{C(\mu(w))\}_{w \in \{a_1, a_2\}^*} = \{(s(w), -|w|, 0)\}_{w \in \{a_1, a_2\}^*}$ contains repeated elements. So let us introduce a subfamily, $\{C(\mu(w))\}_{w \in W'}$, with the property that $\{C(\mu(w)) \mid w \in \{a_1, a_2\}^*\} = \{C(\mu(w)) \mid w \in W'\}$, and

$$w, z \in W', |w| = |z| \implies s(w) \neq s(z) . \quad (29)$$

To show that $C(\mu(w))$ is extremal when $w \in W \cap W'$, it suffices to check that there is no family $\{\lambda_z\}_{z \in W' \setminus w} \subset \mathbb{Z}_{\min}$ such that

$$C(\mu(w)) = \bigoplus_{z \in W' \setminus w} \lambda_z \otimes C(\mu(z)) ,$$

i.e.

$$(s(w), -|w|, 0) = \inf_{z \in W' \setminus w} \lambda_z + (s(z), -|z|, 0) . \quad (30)$$

It follows from (30) that

$$\lambda_z \geq \max(s(w) - s(z), |z| - |w|, 0) .$$

Now, by definition of W and by (29), $\max(s(w) - s(z), |z| - |w|) > 0$ for all $z \in W'$ such that $z \neq w$, and since $\lambda_z \geq \max(s(w) - s(z), |z| - |w|) > 0$ is an integer, we conclude that $\lambda_z \geq 1$. Since this holds for all $z \in W' \setminus w$, the equality (30) cannot hold, because the third coordinate of the right-hand side of (30) must be greater than or equal to 1, whereas the third coordinate of the left hand side of (30) is equal to 0. \square

The counter example of Proposition 4.4 shows that the rational semimodules tools do not apply naturally to max-plus automata problems, such as the ones appearing in [Gau95, Kli99a, Kli99b].

Acknowledgement. The authors thank Guy Cohen and Jean-Pierre Quadrat for having inspired this work by many useful discussions.

References

- [B02] A. Bès. A survey of arithmetical definability. *A tribute to Maurice Boffa, Soc.Math. Belgique*, pages 1–54, 2002.
- [BCG99] P. Butkovič and R. Cuninghame-Green. The equation $A \otimes x = B \otimes y$ over $(\mathbb{R} \cup \{-\infty\}, \max, +)$. 1999. to appear in *Theor. Comp. Sci.*, special issue on maxplus algebras.
- [BCOQ92] F. Baccelli, G. Cohen, G. Olsder, and J. Quadrat. *Synchronization and Linearity*. Wiley, 1992.

- [BH84] P. Butkovič and G. Hegedüs. An elimination method for finding all solutions of the system of linear equations over an extremal algebra. *Ekonomicko-matematicky Obzor*, 20, 1984.
- [BR88] J. Berstel and C. Reutenauer. *Rational Series and their Languages*. Springer, 1988.
- [But94] P. Butkovič. Strong regularity of matrices — a survey of results. *Discrete Applied Mathematics*, 48:45–68, 1994.
- [CGQ96] G. Cohen, S. Gaubert, and J. Quadrat. Kernels, images and projections in dioids. In *Proceedings of WODES'96*, pages 151–158, Edinburgh, August 1996. IEE.
- [CGQ97] G. Cohen, S. Gaubert, and J. Quadrat. Linear projectors in the max-plus algebra. In *Proceedings of the IEEE Mediterranean Conference*, Cyprus, 1997. IEEE.
- [CGQ99] G. Cohen, S. Gaubert, and J. Quadrat. Max-plus algebra and system theory: where we are and where to go now. *Annual Reviews in Control*, 23:207–219, 1999.
- [CGQ01] G. Cohen, S. Gaubert, and J. Quadrat. Duality of idempotent semimodules. In *Proceedings of the Satellite Workshop on Max-Plus Algebras, IFAC SSSC'01*, Praha, 2001. Elsevier.
- [CMQV89] G. Cohen, P. Moller, J. Quadrat, and M. Viot. Algebraic tools for the performance evaluation of discrete event systems. *IEEE Proceedings: Special issue on Discrete Event Systems*, 77(1), Jan. 1989.
- [Con71] J. Conway. *Regular algebra and finite machines*. Chapman and Hall, 1971.
- [CTGG99] J. Cochet-Terrasson, S. Gaubert, and J. Gunawardena. A constructive fixed point theorem for min-max functions. *Dynamics and Stability of Systems*, 14(4):407–433, 1999.
- [ES69] S. Eilenberg and M. Schützenberger. Rational sets in commutative monoids. *J. Algebra*, 13:173–191, 1969.
- [Gau92] S. Gaubert. *Théorie des systèmes linéaires dans les dioïdes*. Thèse, École des Mines de Paris, July 1992.
- [Gau94] S. Gaubert. Rational series over dioids and discrete event systems. In *Proc. of the 11th Conf. on Anal. and Opt. of Systems: Discrete Event Systems*, number 199 in Lect. Notes. in Control and Inf. Sci, Sophia Antipolis, June 1994. Springer.
- [Gau95] S. Gaubert. Performance evaluation of $(\max,+)$ automata. *IEEE Trans. on Automatic Control*, 40(12):2014–2025, Dec 1995.

- [Gau98] S. Gaubert. Exotic semirings: Examples and general results. Support de cours de la 26^{ième} École de Printemps d'Informatique Théorique, Noirmoutier, 1998.
- [GG98] S. Gaubert and J. Gunawardena. The duality theorem for min-max functions. *C.R. Acad. Sci.*, 326:43–48, 1998.
- [GP97] S. Gaubert and M. Plus. Methods and applications of $(\max, +)$ linear algebra. In R. Reischuk and M. Morvan, editors, *STACS'97*, number 1200 in LNCS, Lübeck, March 1997. Springer.
- [GS66] S. Ginsburg and E. H. Spanier. Semigroups, Presburger formulas, and languages. *Pacific Journal of Mathematics*, 16(2), 1966.
- [Gun98] J. Gunawardena, editor. *Idempotency*. Publications of the Isaac Newton Institute. Cambridge University Press, 1998.
- [Kat] R. Katz. Ph.d. thesis, University of Rosario. In preparation.
- [Kli99a] I. Klimann. *Langages, séries et contrôle de trajectoires*. Thèse, Université Paris 7, 1999.
- [Kli99b] I. Klimann. A solution to the problem of (A, B) -invariance for series. 1999. To appear in TCS.
- [Kol92] V. Kolokoltsov. Linear additive and homogeneous operators. In *Idempotent analysis*, volume 13 of *Adv. in Sov. Math.* AMS, RI, 1992.
- [KR94] D. Krob and A. B. Rigny. A complete system of identities for one letter rational expressions with multiplicities in the tropical semiring. *J. Pure Appl. Algebra*, 134:27–50, 1994.
- [Kro93] D. Krob. The equality problem for rational series with multiplicities in the tropical semiring is undecidable. *Int. J. of Algebra and Comput.*, 3, 1993.
- [Kro94] D. Krob. Some consequences of a Fatou property of the tropical semiring. *J. of Pure and Applied Algebra*, 93:231–249, 1994.
- [LMS00] G. L. Litvinov, V. P. Maslov, and G. B. Shpiz. Idempotent functional analysis: An algebraical approach. E-print arxiv:math.FA/0009128, <http://arXiv.org>, 2000.
- [Mai95] J. Mairesse. A graphical approach of the spectral theory in the $(\max, +)$ algebra. *IEEE Trans. Automatic Control*, 40(10), 1995.
- [Mol88] P. Moller. *Théorie algébrique des Systèmes à Événements Discrets*. Thèse, École des Mines de Paris, 1988.

- [Opp78] D. C. Oppen. A $2^{2^{2^n}}$ upper bound on the complexity of Presburger arithmetic. *J. of Comp. and System Sci.*, 16:323–332, 1978.
- [Pin98] J.-E. Pin. Tropical semirings. In J. Gunawardena, editor, *Idempotency*. Cambridge University Press, 1998.
- [Plu98] M. Plus. Max-plus toolbox of scilab. Available from the contrib section of <http://www-rocq.inria.fr/scilab>, 1998.
- [Sch88] A. Schrijver. *Theory of linear and integer programming*. Wiley, 1988.
- [Sim78] I. Simon. Limited subsets of the free monoid. In *Proc. of the 19th Annual Symposium on Foundations of Computer Science*, pages 143–150. IEEE, 1978.
- [Sim90] I. Simon. The nondeterministic complexity of a finite automaton. In M. Lothaire, editor, *Mots – Mélanges offerts à M. P. Schützenberger*, pages 384–400, Paris, 1990. Hermes.
- [SS92] S. N. Samborskiĭ and G. B. Shpiz. Convex sets in the semimodule of bounded functions. In *Idempotent analysis*, pages 135–137. Amer. Math. Soc., Providence, RI, 1992.
- [Wag91] E. Wagneur. Moduloids and pseudomodules. 1. dimension theory. *Discrete Math.*, 98:57–73, 1991.
- [WB96] E. Walkup and G. Borriello. *A general linear max-plus solution technique*. 1996. Appears in [Gun98].
- [Won85] W. Wonham. *Linear multivariable control: a geometric approach*. Springer, 1985. Third edition.
- [Zim77] K. Zimmermann. A general separation theorem in extremal algebras. *Ekonom.-Mat. Obzor*, 13(2):179–201, 1977.



Unité de recherche INRIA Rocquencourt

Domaine de Voluceau - Rocquencourt - BP 105 - 78153 Le Chesnay Cedex (France)

Unité de recherche INRIA Lorraine : LORIA, Technopôle de Nancy-Brabois - Campus scientifique
615, rue du Jardin Botanique - BP 101 - 54602 Villers-lès-Nancy Cedex (France)

Unité de recherche INRIA Rennes : IRISA, Campus universitaire de Beaulieu - 35042 Rennes Cedex (France)

Unité de recherche INRIA Rhône-Alpes : 655, avenue de l'Europe - 38330 Montbonnot-St-Martin (France)

Unité de recherche INRIA Sophia Antipolis : 2004, route des Lucioles - BP 93 - 06902 Sophia Antipolis Cedex (France)

Éditeur

INRIA - Domaine de Voluceau - Rocquencourt, BP 105 - 78153 Le Chesnay Cedex (France)

<http://www.inria.fr>

ISSN 0249-6399