

**TWO-DIMENSIONAL APPROXIMATE LOCAL DtN
BOUNDARY CONDITIONS FOR
ELLIPTICAL-SHAPED BOUNDARIES**

Hélène Barucq, Rabia Djellouli, Anne-Gaëlle Saint-Guirons

► **To cite this version:**

Hélène Barucq, Rabia Djellouli, Anne-Gaëlle Saint-Guirons. TWO-DIMENSIONAL APPROXIMATE LOCAL DtN BOUNDARY CONDITIONS FOR ELLIPTICAL-SHAPED BOUNDARIES. International Conference on Theoretical and Computational Acoustics, Jul 2007, Heraklion, Greece. inria-00339926

HAL Id: inria-00339926

<https://hal.inria.fr/inria-00339926>

Submitted on 19 Nov 2008

HAL is a multi-disciplinary open access archive for the deposit and dissemination of scientific research documents, whether they are published or not. The documents may come from teaching and research institutions in France or abroad, or from public or private research centers.

L'archive ouverte pluridisciplinaire **HAL**, est destinée au dépôt et à la diffusion de documents scientifiques de niveau recherche, publiés ou non, émanant des établissements d'enseignement et de recherche français ou étrangers, des laboratoires publics ou privés.

TWO-DIMENSIONAL APPROXIMATE *LOCAL* DtN BOUNDARY CONDITIONS FOR ELLIPTICAL-SHAPED BOUNDARIES

H. BARUCQ[†], R. DJELLOULI[‡], A. SAINT-GUIRONS[†]

[†]Laboratoire de Mathématiques Appliquées, CNRS UMR 5142, Université de Pau et des
Pays de l'Adour, IPRA-Avenue de l'Université, 64013 Pau, France &
INRIA Futurs Research Center Team-Project Magique3D

[‡]Department of Mathematics, California State University Northridge, Northridge, CA
91330-8313, USA

Abstract

We propose a new class of approximate *local* DtN boundary conditions to be applied on elliptical-shaped exterior boundaries when solving acoustic scattering problems by elongated obstacles. These conditions are : (a) exact for the first modes, (b) easy to implement and to parallelize, (c) compatible with the local structure of the computational finite element scheme, and (d) applicable to exterior elliptical-shaped boundaries that are more suitable in terms of cost-effectiveness for surrounding elongated scatterers. We investigate analytically and numerically the effect of the frequency regime and the slenderness of the boundary on the accuracy of these conditions. We also compare their performance to the second order absorbing boundary condition (BGT2) designed by Bayliss, Gunzburger and Turkel when expressed in elliptical coordinates. The analysis reveals that, in the low frequency regime, the new second order DtN condition (DtN2) retains a good level of accuracy *regardless* of the slenderness of the boundary. In addition, the DtN2 boundary condition outperforms the BGT2 condition. Such superiority is clearly noticeable for large eccentricity values.

1 Introduction

Exterior Helmholtz problems are classical mathematical models for studying scattering problems arising in many applications such as sonar, radar, geophysical exploration, nondestructive testing, etc. Despite their simplicity, this class of problems is not completely solved particularly from a numerical point of view. For example, the computation of the solutions of these problems requires first to limit it to a finite domain. This is often achieved by surrounding the given scatterer(s) (or radiator) by an artificial boundary that is located at some distance (measured in multiples of wavelength of interest) from its surface. A so-called

“nonreflecting” boundary condition is then prescribed on the artificial boundary to represent the “far-field” behavior of the scattered field. The challenge here is the development of a simple but reliable as well as cost-effective computational procedure for representing the far-field behavior of the scattered field. The quest for such conditions is ongoing (see, e.g., the recent review by Turkel in the book [1]).

We propose in this work new two-dimensional approximate *local* DtN boundary conditions to be employed on elliptical-shaped boundaries that are primary candidates for surrounding elongated scatterers. The idea for constructing such conditions is driven by several considerations, chief among them the following two reasons. First, the widely-used second order absorbing boundary condition (BGT2) designed by Bayliss, Gunzburger and Turkel for circular-shaped boundaries [2] performs poorly when it is expressed in elliptical coordinates and applied to elliptical-shaped boundaries in the low frequency regime [3]. The accuracy deteriorates significantly for large eccentricity values of the boundaries as observed in [3]. The damping effect introduced to this condition [4] improves the performance for small eccentricity values. However, the modified BGT2 still performs poorly for eccentricity values larger than 0.6 in the (relatively) low frequency regime (see Figure 6 in [4]). Hence, there is a need for constructing local absorbing boundary conditions (ABC) that extend the range of satisfactory performance. Second, the two-dimensional approximate local DtN conditions designed for circular-shaped boundaries [5] outperforms significantly BGT conditions, particularly for low wavenumber values as reported in [6]. However, using these conditions on circular-shaped exterior boundaries when solving scattering problems by elongated scatterers often leads to larger than needed computational domains, which hampers computational efficiency. This suggests that approximate local DtN boundary conditions designed for elliptical-shaped boundaries is an attractive alternative for improving the computational performance.

Given that, this work is devoted to the construction of these conditions and to the assessment of their performance when employed for solving two-dimensional acoustic scattering problems by elliptical-shaped obstacles. The idea of constructing two-dimensional approximate *local* DtN boundary conditions is not new. Indeed, as stated earlier, such conditions have been already derived for circular-shaped boundaries [5]. The construction procedure adopted in [5] is based on the localization of the truncated global DtN boundary condition [7]. The key ingredient of this procedure is the trigonometric identities that express high order derivatives of sine and cosine functions (see for example Eq. (A4) p. 276 in [5]). However, this property is not satisfied by the periodic Mathieu functions (see p. 376 in [8]). Consequently, the procedure used in [5] is no longer applicable to the truncated global DtN boundary operator when expressed in elliptical coordinates [9, 10]. Hence, the construction methodology we propose for deriving

the class of approximate local DtN boundary conditions in elliptical coordinates can be viewed as an *inverse-type* approach. More specifically, we start from a Robin-type boundary condition with unknown coefficients. Unlike the case of polar coordinates, these coefficients depend on the angle θ of the elliptical coordinates. Such dependence is necessary to preserve the symmetry and local nature of the resulting boundary conditions. Then, we require that the considered condition to be an exact representation of the first modes. Consequently, the coefficients are the unique solution of a linear algebraic system.

We assess mathematically and numerically the performance of the constructed approximate local DtN boundary conditions. More specifically, we analyze the effect of low wavenumber and the eccentricity on the performance of these conditions in the case of two-dimensional scattering problems. We adopt the on-surface radiation condition formulation (OSRC) [11] in order to perform *analytically* this investigation. We note that such formulation is *not* appropriate for the high frequency regime as observed previously in [12]. The main interest in the following analyses is to evaluate the performance of the proposed approximate local DtN conditions at low wavenumber to see if relatively small computational domains can be employed in order to avoid excessive computational cost. The OSRC formulation must be viewed as an extreme case while an exterior elliptical-shaped boundary surrounding an elongated scatterer would be less “demanding” on the boundary condition. The analysis herein shows that the constructed *second-order* local DtN condition retains a good level of accuracy in the low frequency regime for all eccentricity values of the elliptical-shaped boundaries. We must point out that we have also performed a similar investigation when these conditions are employed for solving exterior two-dimensional radiator problems. However, because of space limitation, we do not report in this paper on the results obtained in this case. These results can be found however in [13].

2 Preliminaries

The elliptic cylindrical coordinates (ξ, θ, z) are related to the cartesian coordinates (x, y, z) by the transformation: $x = a \cos \theta$, $y = b \sin \theta$, and $z = z$ where $\theta \in [0, 2\pi)$, $z \in \mathbb{R}$, and a and b are the semi-major and semi-minor axes, respectively. They are given by $a = f \cosh \xi$, $b = f \sinh \xi$, where f represents the *inter-focal* distance and ξ is a nonnegative real number. The *eccentricity*, e on an elliptical cylinder at $\xi = \xi_0$ is given by $e = \frac{1}{\cosh \xi_0} = \sqrt{1 - \frac{b^2}{a^2}}$. Note that $0 < e < 1$.

Furthermore, any incident plane wave u^{inc} can be expressed in this coordinate system as follows

$$u^{\text{inc}} = e^{ikf \cosh \xi (\cos \theta \cos \theta_0 + \tanh \xi \sin \theta \sin \theta_0)}, \quad (1)$$

where the wavenumber k is a positive number and θ_0 is the incident angle.

We consider in this work two-dimensional acoustic scattering problems by elliptical-shaped scatterers. Such restriction allows us however to adopt the OSRC formulation and set the elliptical-shaped artificial boundary on top of the boundary of the obstacle. In addition, we assume, for simplicity, that the scatterers are *sound-soft* [14]. Consequently, the acoustic scattered field u^{scat} solution of a sound-soft elliptical-shaped scatterer can then be expressed in terms of Mathieu functions as [15]

$$\left\{ \begin{array}{l} u^{\text{scat}} = -\sqrt{8\pi} \left[\sum_{m=0}^{\infty} i^m C_{e_m} \text{Re}_m^{(3)}(kf, \cosh \xi) \text{Se}_m(kf, \cos \theta) \right. \\ \left. + \sum_{m=1}^{\infty} i^m C_{o_m} \text{Ro}_m^{(3)}(kf, \cosh \xi) \text{So}_m(kf, \cos \theta) \right], \end{array} \right. \quad (2)$$

where C_{e_m} and C_{o_m} are the Fourier coefficients [15, 3, 4], $\text{Re}_m^{(j)}$ (resp. $\text{Ro}_m^{(j)}$) represents the *even* (resp. *odd*) *radial* Mathieu functions of the j^{th} type (see p. 378 in Reference [8]), Se_m (resp. So_m) represents the *even* (resp. *odd*) *periodic* Mathieu functions (see p. 377 in Reference [8]), and $N_m^{(e)}$ (resp. $N_m^{(o)}$) represents the *even* (resp. *odd*) normalization factor of the periodic Mathieu functions (see p. 378 in Reference [8]). We recall (for example) that the m th elliptical *even* mode is given by [16]

$$u_m = \text{Re}_m^{(3)}(kf, \cosh \xi) \text{Se}_m(kf, \cos \theta); \quad m \geq 0. \quad (3)$$

3 Two-dimensional approximate *local* DtN boundary conditions in elliptical coordinates

The two-dimensional first- (DtN1) and second-order (DtN2) local Dirichlet-to-Neumann boundary conditions, defined on the elliptical-shaped boundary $\xi = \xi_0$, are given by

$$\text{DtN1} : \quad \frac{\partial u}{\partial \xi} = \frac{\sqrt{1-e^2}}{e} \alpha_0 u, \quad (4)$$

$$\text{DtN2} : \quad \frac{\partial u}{\partial \xi} = \frac{\sqrt{1-e^2}}{e(a_0 - a_1)} [(a_0 \alpha_1 - a_1 \alpha_0) u + (\alpha_1 - \alpha_0) D_\theta u], \quad (5)$$

where the constants a_m are the characteristic numbers of the m th even periodic Mathieu functions Se_m [17]. The coefficients α_m are given by

$$\alpha_m = \frac{\text{Re}_m^{(3)'}(eka, e^{-1})}{\text{Re}_m^{(3)}(eka, e^{-1})}; \quad m \geq 0, \quad (6)$$

and the operator D_θ is the following second order differential operator

$$D_\theta = \frac{\partial^2}{\partial \theta^2} - \frac{(eka)^2}{2} (\cos 2\theta) \text{I}.$$

The following four remarks are noteworthy:

- First, the boundary conditions (4), (5) are symmetric and *local* boundary conditions. The local feature of these conditions is of a great interest from a numerical view point. Indeed, the incorporation of these conditions in any finite element code introduces only mass- and stiffness-type matrices defined on the exterior boundary. The characteristic numbers a_n of the n th even periodic Mathieu functions and the coefficients α_n can be computed once for all at the preprocessing level.
- Second, it must be pointed out that when $e = 0$ (the ellipse degenerates to a circle), conditions (4) and (5) are identical to the two-dimensional DtN conditions designed for circular-shaped boundaries [5, 6]. This property can be easily established [13] using the asymptotic behavior of the even radial Mathieu functions of the third type $Re_m^{(3)}$ (see Eqs. (21) and (22), p. 171 and Eq. (37), p. 200 in Ref. [18]).
- Last, approximate local DtN conditions of order higher than two are inappropriate for conventional finite element implementations since they require regularity higher than C^0 . Consequently, we consider in the following only the first- (DtN1) and second-order (DtN2) boundary conditions.

Moreover, the boundary conditions (4) and (5) satisfy, by construction, the following property that one can easily verify:

Lemma 3.1 *The first-order DtN boundary condition (DtN1) given by (4) is an exact representation of the first mode u_0 given by Eq.(3).*

The second-order DtN boundary condition (DtN2) given by (5) is an exact representation of the first even mode u_0 and the second even mode u_1 given by Eq.(3).

Remark 3.2 *We have also constructed a second-order boundary condition that is an exact representation of the first even mode and the first odd mode. The expression of the obtained condition is similar to the condition (5) [13]. The only difference is the replacement of (a) the even radial Mathieu function of the third type $Re_1^{(3)}$ by the odd function $Ro_1^{(3)}$, and (b) the characteristic number a_1 by the one corresponding to the odd periodic Mathieu function So_1 [17]. Similarly, we have also constructed a second-order boundary condition that is an exact representation, in the least-squares sense, of the first two even mode and the first odd mode [13]. We have analyzed the performance of these conditions and found that it is identical to the second-order boundary condition (DtN2) given by Eq. (5) as reported in [13]. Given that, along with space limitation, we only consider in this paper the conditions given by Eq. (4) and Eq. (5) to illustrate the performance of this class of ABCs.*

4 Performance analysis

In the following, we assess analytically and numerically the performance of the approximate local DtN1 and DtN2 boundary conditions given by (4) and (5). More specifically, we analyze the effect of low wavenumber ka and the eccentricity e on the performance of DtN1 and DtN2 in the case of sound-soft scattering problems. We adopt the on-surface radiation condition formulation (OSRC) [11] in order to perform this investigation analytically. As in [3, 4, 6], we assess the performance of the ABCs DtN1 and DtN2 using the *specific impedance* introduced in [19, 20] as a practical tool for measuring the efficiency of ABCs in the context of the OSRC formulation. This *non-dimensional* quantity measures the effect of the truncated medium in physical terms. It provides a convenient indicator of the performance of a given approximate representation. In the elliptical coordinates system, the specific impedance can be expressed as

$$z = \frac{i\sqrt{1-e^2}ka u^{\text{scat}}}{\frac{\partial}{\partial \xi}(u^{\text{scat}})|_{\xi=\xi_0}}. \quad (7)$$

Therefore, the specific impedance z^{exact} corresponding to the exact solution for two-dimensional sound-soft acoustic scattering problems can be computed analytically using $u^{\text{scat}} = -u^{\text{inc}}$ (see Eq. (1)), and the Fourier series given by Eq. (2) to evaluate $\frac{\partial}{\partial \xi}(u^{\text{scat}})|_{\xi=\xi_0}$ (see, for more details, [3, 4, 13]).

4.1 Mathematical results

The following lemma states the expression of the approximate specific impedances on the boundary of a sound-soft elliptical-shaped scatterer at $\xi = \xi_0$. These expressions can be easily derived from Eq. (7) by using $u^{\text{scat}} = -u^{\text{inc}}$ (see Eq. (1)), along with substituting $u = -u^{\text{inc}}$ into the DtN conditions (4) and (5).

Lemma 4.1 *The approximate specific impedance (z^{DtN1}) corresponding to the first order DtN boundary condition (DtN1) is given by*

$$z^{\text{DtN1}} = \frac{ika e}{\alpha_0}. \quad (8)$$

The approximate specific impedance (z^{DtN2}) corresponding to the second order DtN boundary condition (DtN2) is given by

$$z^{\text{DtN2}} = \frac{ika e (a_0 - a_1)}{(a_0\alpha_1 - a_1\alpha_0) - (\alpha_1 - \alpha_0) \left(ika \lambda + (ka)^2 \left(\frac{\partial \lambda}{\partial \theta} \right)^2 + \frac{e^2(ka)^2}{2} \cos(2\theta) \right)}, \quad (9)$$

where the constants a_m are the characteristic numbers of the m th even periodic Mathieu functions Se_m [17], the coefficients α_m are given by Eq. (6), and the parameter λ is given by

$$\lambda = \cos \theta \cos \theta_0 + \sqrt{1-e^2} \sin \theta \sin \theta_0. \quad (10)$$

Remark 4.2 *First, we note that when $e = 0$, that is the ellipse degenerates to a circle, the approximate DtN specific impedances given by Eqs. (8) and (9) are identical to the ones obtained in the case of circular-shaped scatterers and an angle of incident plane wave $\theta = \theta_0$ [6]. Second, we observe that, unlike the exact specific impedance z^{exact} , the DtN1 specific impedance z^{DtN1} does not depend on the observation angle θ . This result suggests that the DtN1 boundary condition is less accurate than the DtN2.*

The next result states the behavior of the specific impedances as $ka \rightarrow 0$. Note that the behavior of z^{exact} has been established in [3, 4], while the behavior of z^{DtN2} is a direct consequence, as shown in [13], of using the asymptotic behavior of the even radial Mathieu functions of the third type $Re_m^{(3)}$ (see Eqs. (21) and (22), p. 171 and Eq. (37), p. 200 in Ref. [18]).

Proposition 4.3 *The asymptotic behavior of the specific impedances of the scattered field on the boundary of an elliptical-shaped obstacle as $ka \rightarrow 0$ is given by*

$$z^{\text{DtN2}} \sim z^{\text{exact}} \sim \pi \frac{ka}{2} + ika \ln(ka). \quad (11)$$

Remark 4.4 *Unlike the case of BGT2 boundary condition in elliptical coordinates (see Eq. (40), p. 3637 in [3], Proposition 4.3 reveals that the asymptotic behaviors of z^{exact} and z^{DtN2} are identical. Note that this behavior is identical to the case of circular-shaped scatterers [6].*

4.2 Illustrative numerical results

We have performed several numerical experiments to assess the performance of the constructed approximate local DtN boundary conditions. However, due the space limitation, we report here the results of one experiment for illustration. These results are obtained for an incident angle $\theta_0 = 0$, two wavenumber values $ka = 0.1, 1$, and three eccentricity values $e = 0.1, 0.6, 0.9$. Note that we have computed the specific impedances using the integral representations of the Mathieu functions given by Eqs. (20.7.25)-(20.7.27) p. 737 in Reference [17], and the *Mathematica* software package. We have used up to 20 terms in the Fourier series (see Eq. (2)). The results depicted in Figure 1 clearly illustrates the superiority of DtN2 over BGT2. Indeed, these results indicate that the performance of DtN2 at low wavenumber values is accurate, as expected from Proposition 4.3. In addition, they show that, unlike BGT2, the accuracy is not sensitive to the eccentricity e . Indeed, one can observe that the accuracy of BGT2 deteriorates significantly when $e \geq 0.6$, as already reported in [3].

$e = 0.1$

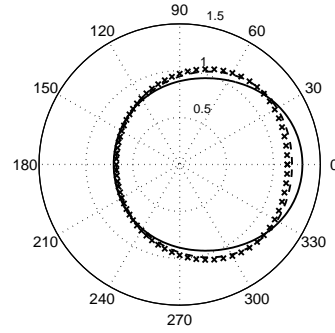
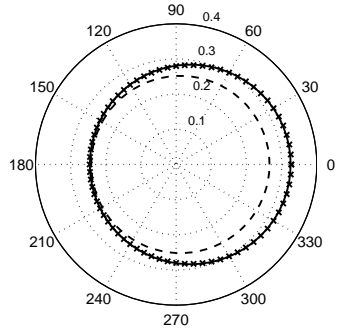

$e = 0.6$

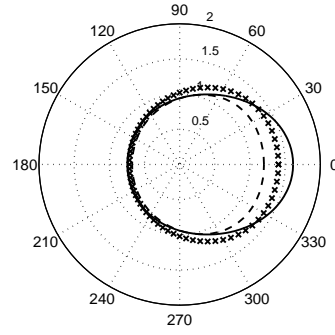
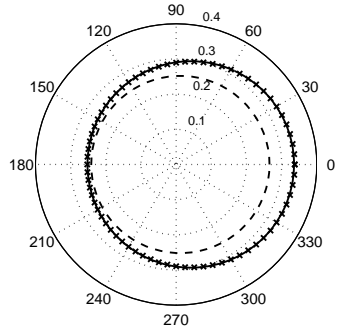

$e = 0.9$

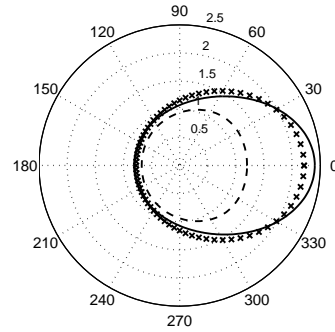
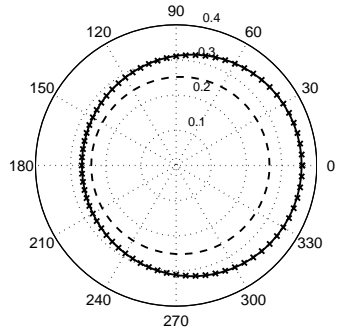

Figure 1: Absolute value of the specific impedance for the exact (solid), the DtN2 (crossed) and the BGT2 (dashed) for the incident angle $\theta_0 = 0$, and for $ka = 0.1$ (left) and $ka = 1$ (right).

5 Conclusion

We have designed a new class of approximate local ABCs to be applied on elliptical-shaped exterior boundaries when solving acoustic scattering problems by elongated obstacles. These conditions are *exact* for the first radiation modes, they are easy to implement and to parallelize, and they preserve the local structure of the computational finite element scheme. The analysis reveals that the new second-order boundary condition DtN2 outperforms the BGT2 condition, and extends the range of satisfactory performance to all eccentricity values.

Acknowledgments

The authors acknowledge the support by INRIA/CSUN Associate Team Program. Any opinions, findings, conclusions or recommendations expressed in this material are those of the authors and do not necessarily reflect the views of INRIA or CSUN.

References

- [1] **E. Turkel**, Iterative methods for the exterior Helmholtz equation including absorbing boundary conditions, In *Computational Methods for Acoustics Problems*, F. Magoulès (ed.), Saxe-Coburg Publications (To Appear).
- [2] **A. Bayliss, M. Gunzberger, E. Turkel**, Boundary conditions for the numerical solution of elliptic equations in exterior regions, *SIAM J. Appl. Math.*, **42** (2), pp. 430-451, 1982.
- [3] **R.C. Reiner, R. Djellouli, I. Harari**, The performance of local absorbing boundary conditions for acoustic scattering from elliptical shapes, *Comput. Methods Appl. Mech. Engrg*, **195**, pp. 3622-3665, 2006.
- [4] **R.C. Reiner, R. Djellouli**, Improvement of the performance of the BGT2 condition for low frequency acoustic scattering problems, *Journal of Wave Motion*, **43**, pp. 406-424, 2006.
- [5] **D. Givoli, J.B. Keller**, Nonreflecting boundary conditions for elastic waves, *Journal of Wave Motion*, **12** (3), pp. 261-279, 1990.
- [6] **I. Harari, R. Djellouli**, Analytical study of the effect of wave number on the performance of local absorbing boundary conditions for acoustic scattering, *Applied Numerical Mathematics*, **50**, pp. 15-47, 2004.
- [7] **J. B. Keller, D. Givoli**, Exact nonreflecting boundary conditions, *J. Comput. Phys.*, **82** (1), 172-192, 1989.
- [8] **J. A. Stratton**, *Electromagnetic Theory*, McGraw-Hill, NY, 1941.
- [9] **M. J. Grote, J. B. Keller**, On nonreflecting boundary conditions, *J. Comput. Phys.*, **122** (2), pp. 231-243, 1995.

- [10] **D. Givoli**, Exact representations on artificial interfaces and applications in mechanics, *AMR*, **52(11)**, pp. 333-349, 1999.
- [11] **G.A.Kriegsmann, A. Taflove, K.R. Umashankar**, A new formulation of electromagnetic wave scattering using an on-surface radiation boundary condition approach, *IEEE Trans. Ant. Prop.*, **35 (2)**, pp. 153-161, 1987.
- [12] **X. Antoine**, Fast approximate computation of a time-harmonic scattered field using the On-Surface Radiation method, *IMA J. Appl. Math.*, **66**, pp. 83-110, 2001.
- [13] **A. Saint-Guirons**, Construction et analyse de conditions aux limites absorbantes pour des problèmes de propagation d'ondes, *Ph.D. thesis*, (In Preparation).
- [14] **D. Colton, R. Kress**, *Inverse Acoustic and Electromagnetic Scattering Theory*, Springer-Verlag, Berlin, second edition, 1998.
- [15] **J. J. Bowman, T. B. A. Senior, P. L. E. Uslenghi**, *Electromagnetic and Acoustic Scattering by Simple Shapes*, Hemisphere Publishing Corporation, New York, NY, 1987.
- [16] **T. B. A. Senior**, Scalar diffraction by a prolate spheroid at low frequencies, *Canad. J. Phys.*, **38**, pp. 1632-1641, 1960.
- [17] **M. Abramovitz, I. Stegun**, *Handbook of Mathematical Functions with Formulas, Graphs and Mathematical Tables*, Dover Publications, New York, 1972.
- [18] **J. Meixner, F.W.Schafle**, *Matieusche funktionen and spheroidfunktionen*, Springer Verlag, Berlin, 1954.
- [19] **T. L. Geers**, Doubly asymptotic approximations for transient motions of submerged structures, *J. Acoust. Soc. Am.*, **64 (5)**, pp. 1500-1508, 1978.
- [20] **T. L. Geers**, Third-order doubly asymptotic approximations for computational acoustics, *J. Comput. Acoust.*, **8 (1)**, pp. 101-120, 2000.