

Nonneutral network and the role of bargaining power in side payments

Eitan Altman, Manjesh Kumar Hanuwa, Rajesh Sundaresan

► **To cite this version:**

Eitan Altman, Manjesh Kumar Hanuwa, Rajesh Sundaresan. Nonneutral network and the role of bargaining power in side payments. NET-COOP 2010 - 4th Workshop on Network Control and Optimization, Nov 2010, Ghent, Belgium. 2010. <inria-00596225>

HAL Id: inria-00596225

<https://hal.inria.fr/inria-00596225>

Submitted on 26 May 2011

HAL is a multi-disciplinary open access archive for the deposit and dissemination of scientific research documents, whether they are published or not. The documents may come from teaching and research institutions in France or abroad, or from public or private research centers.

L'archive ouverte pluridisciplinaire **HAL**, est destinée au dépôt et à la diffusion de documents scientifiques de niveau recherche, publiés ou non, émanant des établissements d'enseignement et de recherche français ou étrangers, des laboratoires publics ou privés.

Nonneutral network and the role of bargaining power in side payments

Eitan Altman
INRIA Sophia-Antipolis
France

Manjesh Kumar Hanawal
INRIA Sophia-Antipolis
University of Avignon, France

Rajesh Sundaresan
Indian Institute of Science
Bangalore, India

Abstract—Representatives of several Internet access providers have expressed their wish to see a substantial change in the pricing policies of the Internet. In particular, they would like to see content providers pay for use of the network, given the large amount of resources they use. This would be in clear violation of the “network neutrality” principle that had characterized the development of the wireline Internet. Our first goal in this paper is to propose and study possible ways of implementing such payments and of regulating their amount. We introduce a model that includes the internaut’s behavior, the utilities of the ISP and of the content providers, and the monetary flow that involves the internauts, the ISP and content provider, and in particular, the content provider’s revenues from advertisements. We consider various game models and study the resulting equilibrium; they are all combinations of a noncooperative game (in which the service and content providers determine how much they will charge the internauts) with a cooperative one - the content provider and the service provider bargain with each other over payments to one another. We include in our model a possible asymmetric bargaining power which is represented by a parameter (that varies between zero to one). We then extend our model to study the case of several content providers. We also provide a very brief study of the equilibria that arise when one of the content providers enters into an exclusive contract with the ISP.

Index Terms—network neutrality; bargaining; two-sided market; game theory; telecommunications policy.

I. INTRODUCTION

The huge growth of the Internet and related electronic commerce and businesses was characterized by a neutral (egalitarian) policy for accessing the global Internet (i) for download or for using services, and (ii) for deploying services or uploading contents. This neutrality principle meant that packets could not be discriminated according to their origin or destination, the application, or the protocol they use.

Those opposing the neutrality argue that (i) some applications (such as peer to peer (P2P) streaming applications) require a lot of costly resources, and (ii) if a neutral policy is pursued, there would be no incentive for investing in the infrastructure of the network in order to upgrade it.

In a nonneutral net, discrimination of packets can mean a selective blocking of packets, selective throttling of flows (allocating less throughput to some flows), having exclusive agreements between the access provider and some content or service providers, and charging traffic in a discriminatory way. Blocking and throttling P2P traffic has been a common practice in several countries, and not just during congestion

epochs [1]. In the USA, such a practice was criticized by the FCC telecom regulation body.

There is one particular economic issue that is at the heart of the conflict over network neutrality. Hahn and Wallsten [2] write that net neutrality “usually means that broadband service providers charge consumers only once for Internet access, do not favor one content provider over another, and do not charge content providers for sending information over broadband lines to end users.” This motivated a study [1] of the implications of being nonneutral and of charging the content providers (CP). Using non-cooperative game theoretic tools, [1] showed that if one provider, say the internet service providers (ISP), has the power to impose payments on the other provider (the CP), not only does the content provider lose control over how much they can pay, the internauts suffer, and moreover, the ISP’s performance degrades. More precisely, reference [1] showed that the only possible equilibrium would be characterized by prices that will induce zero demand from the internauts. This phenomenon does not occur if the price that one provider is requested to pay to the other were fixed by some regulator. See also Njoroge et al [3] for a study of multiple interconnected ISPs, a continuum of internauts and several CPs.

The sources of income (other than side payments between operators) in the model studied in [1] were payments of internauts (to both the ISP as well as the CP), and some third party payment (e.g. publicity income) that the content provider receives. Our objective in this paper is to study mechanisms for determining which provider should pay the other and how much. We are in particular interested in the impact of such mechanisms on the equilibrium.

The side payment from one provider to another is expected to be financed by the income from the internauts and publicity. Cooperative games is a well established scientific area that provides us with tools for designing such mechanisms which, moreover, possess some fairness properties. In [4]-[5] the Shapley value (which is known to have some fairness properties [6]) was used for deciding how revenues from Internauts should be split between the service and the content providers.

We shall focus in this paper on mechanisms based on the Nash bargaining paradigm (which is known in the network engineering context as the proportional fair assignment). It is the unique way of transferring utilities that satisfies a well known set of four axioms [7] related to fairness. We note that assigning the side payments fairly is just part of the

story. In practice one provider may have more weight than the other one in the decision on the amount of side payment. We then say that the provider has a larger bargaining power (we shall make this precise in the next section). As an example, the Spanish ISP “Telefonica” announced on 8 February 2010 that it is considering charging Google, indicating perhaps that the bargaining power of Google is weaker than that of Telefonica. Our work will allow to determine exactly how much payment would go from one provider to another as a function of the bargaining powers of each provider. For quantifying the bargaining power of each side, we follow the approach presented in [8].

Our goal in this paper is to understand a very simple model of a two player game with one agent being a content provider (CP) and another agent being an internet service provider (ISP). Several ancillary parties are also involved – the users who respond to prices via a demand function, advertisers who are the main providers of revenue, and an arbitrator who regulates the side payments taking into account the bargaining power of the players. We then extend the results to the case when there are multiple content providers. Finally, we provide some results for the case when there are two CPs, but the first CP has an exclusive contract with the ISP.

II. THE CASE OF A SINGLE CP AND A SINGLE ISP

We first begin with the simple case of a single CP and a single ISP. All the internauts are connected to the ISP, and can access the content of the CP only through the ISP. See Figure 1 for a payment flow diagram. The various parameters of the network neutrality game are as follows.

Parameter	Description
p^s	Price per unit demand paid by the users to the ISP. This can be positive or negative.
p^c	Price per unit demand paid by the users to the CP. This too can be positive or negative.
$d(p^s, p^c)$	Demand as a function of prices. We shall take this to be $d(p^s, p^c) = [D_0 - \alpha(p^s + p^c)]_+$, where $[x]_+ = \max\{x, 0\}$ is the positive part of x .
p^a	Advertising revenue per unit demand, earned by the CP. This satisfies $p^a \geq 0$.
p^d	Price per demand paid by the CP to the ISP. This can be either positive or negative.
U_{ISP}	The revenue or utility of the ISP, given by $d(p^s, p^c)(p^s + p^d)$.
U_{CP}	The revenue or utility of the CP, given by $d(p^s, p^c)(p^c + p^a - p^d)$.
γ	Bargaining power of the ISP with respect to the CP. This satisfies $0 < \gamma < 1$.

We consider two interesting games. The timing for the first game is as follows.

- The ISP and the CP bargain over the payment p^d from the CP to the ISP. This can be positive or negative.

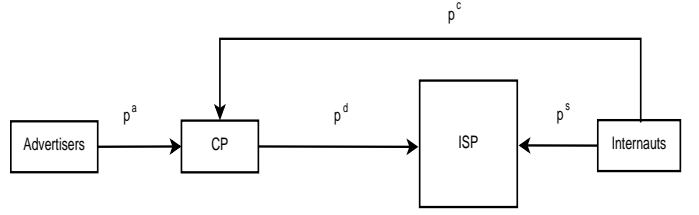

Fig. 1. Monetary flow in a nonneutral network.

- The CP sets the price p^c . The ISP sets the price p^s . Both set their prices simultaneously.
- The internauts react to the prices and set the demand.

In the second game, bargaining is done later:

- The ISP and the CP set their respective access prices p^s and p^c simultaneously.
- The ISP and the CP bargain over the payment p^d from the CP to the ISP. This can be positive or negative.
- The internauts react to the prices and set the demand.

The first game arises when the charges per unit demand can change over a comparatively faster time-scale while the CP-ISP price changes over a slower time-scale. The second one is an interesting case that may arise in a regulatory setting where the prices per unit demand charged to the internauts varies over a slower time-scale, but the ISP and the CP can quickly renegotiate their prices. We analyze both models via backward induction and identify the equilibria.

For a fixed p^s and p^c , bargaining results in an agreement of a payment p^d from the CP to the ISP, determined by

$$p^{d*} \in \arg \max_{p^d} U_{\text{ISP}}^\gamma \times U_{\text{CP}}^{1-\gamma}.$$

The parameter γ determines the bargaining power of the ISP with respect to the CP. When p^{d*} is negative, the ISP is the one that makes a payment to the CP.

We now discuss some properties of the bargaining solution.

If we take $\gamma = 1/2$ then the maximization is equivalent to that of the product of the utilities of the ISP and the CP. This is then the standard Nash bargaining approach [7] for resource allocation, known in networking as the proportional fair allocation [9]. (It is known to be the unique assignment satisfying a set of four axioms.) To understand the case of general γ , consider first the problem of maximizing $U_{\text{ISP}}^{m_1} U_{\text{CP}}^{m_2}$ where m_1 and m_2 are integers. The form of the objective function suggests that we are simply searching for a standard proportional fairness solution but where there are m_1 ISP’s and m_2 content providers. Thus the ISP is said to have a bargaining power equivalent to that of m_1 players, and the CP equivalent to that of m_2 players. Finally, we note that $\arg \max(U_{\text{ISP}}^{m_1} U_{\text{CP}}^{m_2})$ is the same as that of $(U_{\text{ISP}}^\gamma U_{\text{CP}}^{1-\gamma})$ where $\gamma := m_1/(m_1 + m_2)$.

Remark: The optimization problem involved in computing the proportional fair solutions, that of maximizing the product of utilities, may have some constraints. We do not modify the constraints when altering m_1 or m_2 . The change in m_1 or m_2

merely corresponds to a re-weighting of the utilities and not of addition or removal of users.

We next observe that the game problem is equivalent to replacing all utilities by the log of the utilities. We may imagine that the bargaining is done by another player, whose (log) utility equals

$$\bar{U}_{\text{regulator}} := \gamma \bar{U}_{\text{ISP}} + (1 - \gamma) \bar{U}_{\text{CP}}, \quad (1)$$

where $\bar{U}_{\text{ISP}} = \log U_{\text{ISP}}$ and $\bar{U}_{\text{CP}} = \log U_{\text{CP}}$. At least one previous work has already used as utilities the linear combination of performance measures of other players and interpreted γ as some measure of the ‘‘degree of cooperation’’, see [10], in other contexts.

Let us now return to our games. In the first game, the CP and the ISP bargain over Nash equilibria. In the second, they choose p^a and p^c knowing that they will bargain subsequently. A summary of the results for the single-CP single-ISP games are as follows.

1) In both cases, there exists a pure strategy Nash equilibrium, in a sense that will be made precise, with strictly positive demand and strictly positive utilities for the agents. In the pre-bargaining problem there are other zero-demand equilibria. In the post-bargaining problem, the aforementioned pure strategy Nash equilibrium is unique.

2) In all cases with strictly positive demand, users pay the ISP. But users pay the CP only if the advertising revenue is small. Otherwise the CP subsidizes the users.

3) If either of the agents have control over p^d , the equilibrium demand is zero. None of the parties benefit from this situation. On the contrary, if p^d is under the control of a disinterested arbitrator, there is an equilibrium where every one benefits. This is the key insight gained from our analysis, that some sort of regulation can bring benefits to all.

4) Interestingly, if the agents bargain beforehand and the strictly positive demand equilibrium ensues, the payments by the users and resulting utilities of all agents are independent of the actual value of p^d .

5) If the agents bargain beforehand, over Nash equilibria, then demand settles at a lower value than if the agents bargain after setting their prices.

6) If the agents bargain beforehand, they end up with equal revenues. If they bargain afterward, they share the net revenue in the proportion of their bargaining power.

7) Finally, if $\gamma \in [\frac{4}{9}, \frac{5}{9}]$, then both agents prefer to fight it out after setting their prices. For $\gamma > 5/9$, the ISP prefers post-arbitration, and for $\gamma < 4/9$, the CP prefers post-arbitration.

While the above appear to suggest that post-arbitration may prove to be good to the interauts, there are no pure-strategy Nash equilibria in the post-arbitration game when there are two or more CPs under a model where the demand for content from a CP is positively correlated with a competing CP’s price. We shall return to this in a later section.

With these motivating remarks, we shall now proceed to state these claims in a precise fashion and to prove them. In subsequent sections we shall study the extension of the

above results to the case of multiple CPs and to the case of an exclusive contract between one of the CPs and the ISP.

A. Bargaining over Nash equilibria

We first consider the case where the agents bargain over Nash equilibria. Both agents bargain over the choice of p^d , knowing that they will subsequently play a simultaneous action game where the ISP and CP will choose p^s and p^c , respectively. Our main result here is summarized as follows.

Theorem 1. *When the CP and the ISP bargain beforehand over Nash equilibria, we have the following complete characterization of all pure strategy Nash equilibria.*

(a) *Among profiles with strictly positive demand, there is a unique pure strategy Nash equilibrium with the following properties:*

- *The uniqueness is up to a free choice of p^d .*
- *At equilibrium, we have:*

$$p^s = \frac{D_0 + \alpha p^a}{3\alpha} - p^d, \quad (2)$$

$$p^c = \frac{D_0 - 2\alpha p^a}{3\alpha} + p^d. \quad (3)$$

- *The net user payment per demand $p^s + p^c$ is unique and is given by*

$$p^s + p^c = \frac{2D_0 - \alpha p^a}{3\alpha}.$$

Any p^d paid by the CP is collected from the user and further returned back to the user by the ISP.

- *The demand is unique and is given by $(D_0 + \alpha p^a)/3 > 0$.*
- *The utilities of the ISP and CP are equal and given by*

$$U_{\text{ISP}} = U_{\text{CP}} = \frac{(D_0 + \alpha p^a)^2}{9\alpha}.$$

(b) *For each choice of p^d , a strategy profile (p^s, p^c) constitutes a Nash equilibrium with zero demand if and only if the following two inequalities hold:*

$$p^s \geq D_0/\alpha + p^a - p^d, \quad (4)$$

$$p^c \geq D_0/\alpha + p^d. \quad (5)$$

Proof: We first observe that at equilibrium, U_{ISP} and U_{CP} are both nonnegative. If not, the ISP (resp. CP) has strictly negative utility. He can raise the price p^s (resp. p^c) to a sufficiently high value so that demand becomes zero, and therefore $U_{\text{ISP}} = 0$ (resp. $U_{\text{CP}} = 0$). Thus a deviation yields a strict increase in utility and therefore cannot be an equilibrium. It follows that at equilibrium, we may take the revenues per demand for the ISP and CP to be nonnegative, i.e., $p^s + p^d \geq 0$, and $p^c + p^a - p^d \geq 0$.

We next deduce (b), i.e., all the pure strategy NE with zero demand. Consider a fixed p^d . If a pair (p^s, p^c) were an equilibrium with zero demand, then clearly

$$D_0 \leq \alpha(p^s + p^c),$$

and

$$U_{\text{ISP}} = d(p^s, p^c) \times (p^s + p^d) = 0.$$

Moreover, the ISP should not be able to make his utility positive, i.e., any p^s that makes demand strictly positive, $p^s < D_0/\alpha - p^c$, must also render price per unit demand zero or negative, $p^s + p^d \leq 0$. This can happen only if $(D_0/\alpha - p^c) + p^d \leq 0$ which is the same as (5). Similarly, the CP should not be able to make his utility positive, i.e., any p^c that makes demand strictly positive, $p^c < D_0/\alpha - p^s$, must render CP price per unit demand nonpositive, $p^c + p^a - p^d \leq 0$. This can happen only if $(D_0/\alpha - p^s) + p^a - p^d \leq 0$ which is the same as (4). This proves the necessity of (4) and (5). To prove sufficiency, if (5) fails, then with $\varepsilon = (D_0/\alpha + p^d) - p^c > 0$, the ISP can set $p^s = D_0/\alpha - p^c - \varepsilon/2$ yielding a demand of $\varepsilon/2$ and a revenue per demand of $\varepsilon/2$ and thus a strictly positive utility for the ISP. If (4) fails, the CP can analogously get a strictly positive demand. Thus (b) holds.

Let us now search for an equilibrium with a strictly positive demand. Such a (p^s, p^c) must lie in the interior of the set of all pairs satisfying $D_0 \geq \alpha(p^s + p^c)$. As U_{ISP} is concave in p^s for a fixed p^c and p^d , whenever the utility is strictly positive, we must have a local maximum at equilibrium, i.e.,

$$\begin{aligned} \frac{\partial U_{\text{ISP}}}{\partial p^s} &= \frac{\partial}{\partial p^s} (D_0 - \alpha(p^s + p^c))(p^s + p^d) \\ &= D_0 - \alpha p^s - \alpha p^c - \alpha(p^s + p^d) \\ &= 0, \end{aligned}$$

which yields

$$p^s = \frac{D_0 - \alpha p^c - \alpha p^d}{2\alpha}.$$

Analogously, U_{CP} is concave in p^c for fixed p^s and p^d wherever the function is positive, and so the equilibrium p^c should be a local maximum, i.e.,

$$\begin{aligned} \frac{\partial U_{\text{CP}}}{\partial p^c} &= \frac{\partial}{\partial p^c} (D_0 - \alpha(p^s + p^c))(p^c + p^a - p^d) \\ &= D_0 - \alpha p^s - \alpha p^c - \alpha(p^c + p^a - p^d) \\ &= 0, \end{aligned}$$

which yields

$$p^c = \frac{D_0 - \alpha p^s - \alpha(p^a - p^d)}{2\alpha}.$$

Solving these two simultaneous equations in the variables p^s and p^c , we see that p^s and p^c are given by (2) and (3), respectively. Note that the choice of p^d is free. Once this is chosen, this fixes both p^s and p^c . This proves the second bullet. We shall return to prove the first bullet after proving the others.

Adding these two, we see that $p^s + p^c$ is a constant for each such equilibrium. Choice of p^d fixes both p^s and p^c . This is true for any Nash equilibrium with a strictly positive demand. Furthermore, any p^d that is paid reduces p^s by the same amount and increases p^c by that amount. This proves the third bullet.

The last two bullets follow by direct substitutions into $d(p^s, p^c)$, U_{ISP} , and U_{CP} .

As a consequence of the observation that $U_{\text{ISP}} = U_{\text{CP}}$ at any equilibrium regardless of the value of p^d , we have

$$U_{\text{ISP}}^\gamma \times U_{\text{CP}}^{1-\gamma}$$

is independent of p^d at any equilibrium, for any fixed bargaining power $\gamma \in (0, 1)$. The arbitrator may thus pick any p^d . This proves the first bullet. (This observation holds even for zero-demand equilibria). The proof is now complete. ■

Remarks: 1) Every choice of p^d can also result in the undesirable zero-demand equilibria, and not just the desirable equilibrium with strictly positive demand.

2) For this strictly positive demand equilibrium, the most natural choices of p^d are those that make one of the payments zero. For example, when p^d itself is 0, there is no payment from CP to the ISP. When p^d is set such that $p^c = 0$, there is no payment from the user to the CP. When p^d is set to make $p^s = 0$, there is no payment from the user to the ISP.

3) If one places the additional restriction that $p^s \geq 0$, the only effect of this constraint is that the choice of p^d is restricted to $p^d \leq (D_0 + \alpha p^a)/(3\alpha)$, and the above theorem continues to hold.

4) It is easily seen that if p^d is controlled by either agent, the only equilibria fall amongst the deadlocking zero demand points. Thus bargaining beforehand induces a good equilibrium point.

B. Bargaining after actions

We next consider the case when the CP and ISP decide on their respective prices first, knowing that they will subsequently bargain over p^d , say in the presence of the arbitrator.

Theorem 2. *When the CP and the ISP set prices simultaneously before agreeing on p^d and then bargain in the presence of an arbitrator, there is a unique pure strategy Nash equilibrium with the following properties:*

- The uniqueness is up to a free choice of either p^s or p^c . Without loss of generality, we may assume a free p^s .
- At equilibrium, the net user payment per demand is uniquely given by

$$p^s + p^c = \frac{D_0 - \alpha p^a}{2\alpha}.$$

- The demand is unique and is given by $(D_0 + \alpha p^a)/2 > 0$.
- The arbitrator will set p^d so that the net revenue per demand $p^s + p^c + p^a = \frac{D_0 + \alpha p^a}{2\alpha}$ is shared in the proportion γ and $1 - \gamma$ by the ISP and the CP, respectively.

Proof: As in the previous section, it is clear that the revenues per demand and the utilities for both agents are nonnegative. If this is not the case, the aggrieved CP or the ISP guarantees himself a strictly larger zero utility by raising the price under his control so that demand reduces to 0.

Let us now perform a search for equilibria with strictly positive demand. Such a (p^s, p^c) is an interior point among all those pairs that satisfy $D_0 - \alpha(p^s + p^c) \geq 0$. Consider a

fixed interior point (p^s, p^s) . The arbitrator sets p^d to

$$\begin{aligned} & \arg \max_{p^d} U_{\text{ISP}}^\gamma \times U_{\text{CP}}^{1-\gamma} \\ & = \arg \max_{p^d} [\gamma \log(p^s + p^d) + (1 - \gamma) \log(p^c + p^a - p^d)], \end{aligned}$$

where the equality follows because the demand can be pulled out of the optimization. The optimization is over the set of p^d that ensure that the arguments inside the logarithm remain strictly positive. It is easy to see that the latter function is concave in p^d , and thus the maximizing p^d satisfies

$$\frac{\gamma}{p^s + p^d} - \frac{1 - \gamma}{p^c + p^a - p^d} = 0,$$

which yields $p^d = \gamma(p^c + p^a) - (1 - \gamma)p^s$.

Substitution of this p^d yields

$$\begin{aligned} p^s + p^d &= \gamma(p^s + p^c + p^a) \\ p^c + p^a - p^d &= (1 - \gamma)(p^s + p^c + p^a). \end{aligned}$$

Clearly, $p^s + p^c + p^a$ is the net revenue per demand for both ISP and CP put together, and the ISP and the CP share this booty in the fraction of their bargaining powers.

Knowing this action of the arbitrator, the ISP will respond optimally to a CP's p^c by maximizing

$$U_{\text{ISP}} = d(p^s, p^c)(p^s + p^d) = (D_0 - \alpha(p^s + p^c)) \times \gamma(p^s + p^c + p^a).$$

This is a concave function of p^s , and the maximum is at

$$p^s = \frac{D_0 - \alpha p^a}{2\alpha} - p^c. \quad (6)$$

Similarly, for an ISP's p^s , the CP's best response is

$$p^c = \frac{D_0 - \alpha p^a}{2\alpha} - p^s,$$

which is the same equation as (6).

At equilibrium, we thus have $p^s + p^c$ uniquely determined and given by the second bullet. A substitution yields that the demand is given by

$$d(p^s, p^c) = D_0 - \alpha(p^s + p^c) = \frac{D_0 + \alpha p^a}{2},$$

which proves the third bullet.

The revenue per demand is easily seen to be $(D_0 + \alpha p^a)/(2\alpha)$. Further substitution yields that net revenue is

$$d(p^s, p^c)(p^s + p^c + p^a) = (D_0 + \alpha p^a)^2/(4\alpha),$$

a strictly positive quantity shared in proportion of the bargaining powers by the ISP and CP. This proves the last bullet.

Finally, for any p^s , the arbitrator will set p^d to ensure this proportion, and thus p^s may be taken as a free variable. Each p^s and p^c satisfying the above conditions is a Nash equilibrium. This proves the first bullet.

Finally, it still remains to prove that there is no zero-demand equilibrium. Suppose that (p^s, p^c) is such that we get a zero-demand, i.e., $D_0 \leq \alpha(p^s + p^c)$. With $\varepsilon = (D_0 + \alpha p^a)/2 > 0$, the ISP can set his price to

$$p^s = D_0/\alpha - p^c - \varepsilon/\alpha$$

yielding a demand $D_0 - \alpha(p^s + p^c) = \varepsilon > 0$ and a revenue

$$\gamma(p^s + p^c + p^a) = \gamma(D_0/\alpha - \varepsilon/\alpha + p^a) = \gamma\varepsilon/\alpha > 0,$$

and therefore a strictly positive utility. A unilateral deviation yields the ISP a strict increase in his utility. Thus such a (p^s, p^c) cannot be a pure-strategy equilibrium. This concludes the proof. ■

Remarks: 1) The equilibrium utility for the ISP under post-bargaining is easily seen to be $9\gamma/4$ fraction of that under pre-bargaining. Clearly then, post-bargaining is favourable if $\gamma \geq 4/9$.

2) Similarly, the equilibrium utility for the CP under post-bargaining is $9(1-\gamma)/4$ fraction of that under pre-bargaining. The CP prefers post-bargaining if $1 - \gamma \geq 4/9$ or $\gamma \leq 5/9$.

3) Thus, if $\gamma \in [\frac{4}{9}, \frac{5}{9}]$, both will prefer post-bargaining.

4) For $\gamma > 5/9$, ISP prefers post-bargaining while CP prefers pre-bargaining. Opposite is the case when $\gamma < 4/9$.

III. THE CASE OF MULTIPLE CPS

We now consider the case when there are several content providers. Internauts connect to each of the content providers through the single ISP. See figure 2. The parameters of this game are given as follows.

Parameter	Description
n	Number of content providers.
p_i^s	Price per unit demand paid by the users to the ISP for connection to CP i . This can be positive or negative.
p_i^c	Price per unit demand paid by the users to CP i . This too can be positive or negative.
p_i^a	Advertising revenue per unit demand, earned by the CP. This satisfies $p_i^a \geq 0$.
p_i^d	Price per demand paid by the CP to the ISP. This can be either positive or negative.
p^x	Vectors of aforementioned prices, where x is one of s, c, a, d .
$d_i(p^s, p^c)$	Demand for CP i as a function of the prices. See (7) below and the following discussion.
U_{ISP}	The revenue or utility of the ISP, given by $\sum_i d_i(p^s, p^c)(p_i^s + p_i^d)$.
$U_{\text{CP},i}$	The revenue or utility of the CP, given by $d_i(p^s, p^c)(p_i^c + p_i^a - p_i^d)$.
γ_i	Bargaining power of the ISP with respect to CP i .

The demand function for content from CP i is such that it depends on p^s and p^c only through the sum $p^s + p^c$. Moreover, if the i th CP and ISP increase their prices, demand for content from the i th CP goes down. On the other hand, when the price of the j th CP increases, $j \neq i$, since demand for content from the j th CP goes down, this frees up some capacity thereby providing a marginally better delay experience. This positive effect creates a marginal increase in the demand for content from the other CPs, in particular, an increase in the demand

for content from CP i . We thus model demand for the i th content as a function of the prices as follows:

$$d_i(p^s, p^c) = \left[D_0 - \alpha(p_i^s + p_i^c) + \beta \sum_{j:j \neq i} (p_j^s + p_j^c) \right], \quad (7)$$

provided each of the demands are strictly positive. Further thought suggests that when demand d_i is zero, additional increase in $p_i^s + p_i^c$ holds the demand at zero. The capacity freeing that we indicated earlier no longer occurs and the additional price rise will have no tangible effect on the other internauts' behavior. Let E_n denote the all-one vector of size $n \times 1$.

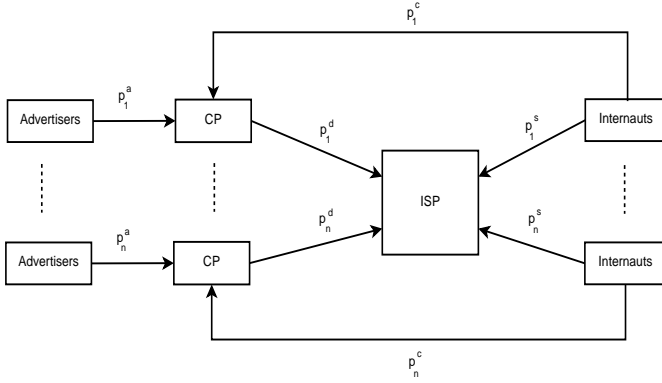

Fig. 2. Monetary flow in a nonneutral network with multiple CPs.

For simplicity, however, in the pre-bargaining case, we restrict attention to the case when each demand is strictly positive. In other words, given the other prices, CP i will not set a price higher than what makes d_i zero, i.e., that there is a joint constraint on the price vector that $d_i(p^s, p^c) > 0$ for every i , i.e.,

$$D_0 - \alpha(p_i^s + p_i^c) + \beta \sum_{j:j \neq i} (p_j^s + p_j^c) > 0, \quad i = 1, \dots, n. \quad (8)$$

This may be compactly summarized by defining the matrix $A = (\alpha + \beta)I_n - \beta J_n$ where I_n is the identity matrix of size $n \times n$, and J_n is the square matrix with all-one entries of size $n \times n$. The matrix A has diagonal entries α and all off-diagonal entries $-\beta$. Then the constraint (8) in matrix notation is

$$D_0 E_n - A(p^s + p^c) > 0. \quad (9)$$

By summing (8) over all i and setting the sum price $P = \sum_i (p_i^s + p_i^c)$, we see that the total demand is

$$nD_0 - (\alpha - (n-1)\beta)P$$

when demand for each content is strictly positive. For this to be negatively correlated with the average price per unit demand P/n , we must have that $(n-1)\beta \leq \alpha$, an assumption that we make from now on. As before we assume that p_i^s and p_i^c can be negative, i.e., the ISP and the CPs can pay the internauts for their usage, with a consequent increase in demand. Finally, it is a simple matter to verify that U_{ISP} is a concave quadratic

function of the vector of service provider's price vector per unit demand p^s . Indeed the Hessian matrix is simply $-2A$. Matrices of this form arise quite often in the sequel. Since this is -2α times the matrix

$$(1 - \rho)I_n + \rho J_n$$

where $\rho = -\beta/\alpha$, a matrix that has $1 - \rho$ repeated as eigenvalue $n - 1$ times and $1 + \rho(n - 1)$ once, and is therefore positive semidefinite by our assumption that $(n - 1)\beta \leq \alpha$ (positive definite if strict inequality), we have that the Hessian is negative semidefinite. This yields that U_{ISP} is a concave function of p^s .

The timing of actions for the games are indicated as follows.

- The ISP bargains with each of the CPs, separately and simultaneously, over the payment p^d from the CPs to the ISP. This can be positive or negative. In bargaining with CP i , the ISP shall bring only that revenue into consideration which is generated by internauts connected to CP i .
 - All the CPs choose their price p_i^c . The ISP chooses the vector p^s . All these actions are taken simultaneously.
 - The internauts react to the prices and set their demands.
- As before, bargaining comes later in the second game.
- The ISP and each of the CPs set their respective access prices p^s and p_i^c simultaneously.
 - The ISP and each of the CPs bargain over the payment p_i^d from the CP to the ISP. This can be positive or negative. Yet again, the ISP shall be able to bring only that revenue into consideration which is generated by internauts connected to CP i .
 - The internauts react to the prices and set their demands.

The case when $\beta = 0$ is easily handled in either scenario. The actions of the various CPs (prices) do not influence each other. Though the ISP's utility is the sum over all revenues accrued from access to each CP, in bargaining with CP i , only the revenue generated by accesses to content of CP i matters. The ISP's utility is thus separable, and the problem separates into n single-CP single-ISP problems. The results of Theorems 1 and 2 immediately extend to this case. Notably, an equilibrium with strictly positive demand exists in either scenario. Further, in case of bargaining before-hand, all combinations, with zero-demand equilibria for some contents (components) and strictly positive (unique) demand for other contents, also exist. We shall henceforth assume that $\beta > 0$.

A. Bargaining over Nash equilibria

As indicated earlier, we assume a joint constraint on the prices in this section. Zero-demand equilibria are thus not studied. We now argue that the qualitative conclusions of Theorem 1 for equilibria with strictly positive demand continue to hold. Suppose for instance that all the CPs and the ISP do not keep any revenue, and transfer the collected advertisement payments to the internauts. In other words, $p^s + p^c = -p^a$. The matrix A is as defined before. Then, the demand vector is

$$D_0 E_n - A(p^s + p^c) = D_0 E_n + A p^a.$$

We make the assumption that in this situation, which is rather favorable to the internauts, the demand vector is nonnegative, i.e., this is a feasible profile with contents from all CPs accessed. The result below is under this hypothesis.

Theorem 3. *Assume $\alpha > (n-1)\beta > 0$. Let p^a be such that the vector $D_0E_n + Ap^a$ is made up of nonnegative entries. Let the CPs and the ISP bargain beforehand. Among profiles with strictly positive demand, there is a unique pure strategy Nash equilibrium with the following properties.*

- The uniqueness is up to a free choice of the vector p^d .
- At equilibrium, for each i , there exist constants g_i and h_i that depend only on p^a , D_0 , α , β such that

$$\begin{aligned} p_i^s &= g_i - p_i^d \\ p_i^c &= h_i + p_i^d, \end{aligned}$$

- For each CP i , the net internaut payment per demand is unique and is given by $p_i^s + p_i^c = g_i + h_i$. Any payment p_i^d paid by the CP is collected from the internaut and further returned to the internaut by the ISP.
- The demand vector is unique and does not depend on p^d .
- The revenues per unit demand, and therefore the total revenues collected by the CPs and the ISP, does not depend on p^d .

The recipe for the proof is identical to that of Theorem 2, only with some matrix algebra.

Remarks: 1) The hypothesis that $(D_0E_n + Ap^a)$ is made of nonnegative entries holds, for example, when revenues from advertisers are either the same, or when D_0 is large. Under the hypothesis, it turns out that contents of all CPs are downloaded when all revenue is transferred to the respective internauts.

2) Yet again we notice that the actual choice of p^d does not affect the net cost to internaut per unit demand, nor does it affect the equilibrium demand. It merely affects the way in which the payment by internaut is split between CP i and ISP. The mere fact that they agreed on an *arbitrary* p^d suffices to get an equilibrium more favorable than the case when p^d is under the control of one of the players.

3) The zero-demand equilibria remain to be characterized.

4) When $\tau \lesssim 1$, any increase in price of CP i causes a reduction in demand for that content, but results in nearly similar magnitude increase in demand of all other contents. The ISP remains nearly fully utilized. This puts the ISP in an advantageous position, and one anticipates that the ISP prices are high. The solution to p^s does indeed exhibit this behaviour with a $1 - \tau$ in the denominator.

B. Bargaining after setting prices

As done previously, the ISP and the CPs will choose their respective prices knowing that the revenue they will get is the outcome of bargaining. In this section, we do not place the constraint that demand be strictly positive. The ISPs and the CPs are free to set any price they wish and no joint constraints are placed. Thus we shall aim to characterize all equilibria, including those with zero demand.

We shall present our results under a condition on the bargaining powers, namely, the matrix H with entries

$$H_{ij} = \begin{cases} \gamma_i^{-1} & i = j, \\ -(\frac{\beta}{\alpha}) \left(\frac{\gamma_i^{-1} + \gamma_j^{-1}}{2} \right) & i \neq j, \end{cases} \quad (10)$$

is negative definite. As we will see later, this condition arises to keep the utility of the ISP a concave function of p^s . It holds for example when the γ_i 's are all equal and under our standing assumptions: $\alpha \geq (n-1)\beta$ and $D_0E_n + Ap^a \geq 0$.

As in the $n = 1$ case, the ISP and CP i will share $p_i^s + p_i^c + p_i^a$, the revenue coming from internauts accessing content from CP i , in the proportion γ_i and $1 - \gamma_i$. This revenue will turn out to be nonnegative because otherwise CP i can just opt out. More compactly, $p^s + p^a + p^c \geq 0$. Recall the earlier condition (9) on the prices so that demands are nonnegative.

One immediate observation is that all utilities and the constraints depend on p_i^s and p_i^c only through the sum $p_i^s + p_i^c$. While this sum is bounded if the demand vector is to be strictly positive, neither p_i^s nor p_i^c need be bounded, and so the action sets for each of the agents is unbounded. Our main result is then the following mixed bag. (Recall that the case $\beta = 0$ was already considered and disposed).

Theorem 4. *Let the matrix H given by (10) be negative definite. Also let $\alpha > (n-1)\beta > 0$ and $D_0E_n + Ap^a \geq 0$. For the case when bargaining is done after setting the prices, the following hold.*

- There exists no pure strategy Nash equilibrium.
- If the prices are constrained to lie in a convex, closed, and bounded set, there exists a pure strategy Nash equilibrium on the boundary.

Thus even though post-arbitration in the single-CP single ISP case always gave a unique Nash equilibrium with the desirable strictly positive demand, the desirable feature disappears when there are multiple CPs and $\beta > 0$. Pre-arbitration continues to yield a unique Nash equilibrium among those profiles with strictly positive demand vectors.

IV. THE EXAMPLE OF AN EXCLUSIVE CONTRACT

We now study the multiple CP problem but in a setting where the ISP and one of the CPs, say CP 1, enter into an exclusive contract. ISP and CP 1 now form a super $\overline{\text{ISP}}$. This situation also arises when the ISP himself provides content. In this paper, we study only the case when the prices are constrained (jointly) to lie within the set that yields a strictly positive demand. Relaxation of this constraint is under study. Further, we restrict attention to $n = 2$ CPs.

Note that p_1^d no longer matters as this is an internal exchange within the agent $\overline{\text{ISP}}$ of no consequence to the overall game. The utility of $\overline{\text{ISP}}$ is

$$\begin{aligned} U_{\overline{\text{ISP}}} &= d_1(p^s, p^c)(p_1^s + p_1^c + p_1^a) + d_2(p^s, p^c)(p_2^s + p_2^d), \\ U_{\text{CP},2} &= d_2(p^s, p^c)(p_2^c + p_2^a - p_2^d). \end{aligned}$$

Note that $d_1(p^s, p^c) = D_0 - \alpha(p_1^s + p_1^c) + \beta(p_2^s + p_2^c)$ with an analogous formula for $d_2(p^s, p^c)$, since our current focus in

this paper is study of equilibria with strictly positive demand. Calculations entirely analogous to earlier ones show that the Hessian of $U_{\overline{\text{ISP}}}$ with respect to the variables $(p_1^s + p_1^c, p_2^s)$ is $-2A$, where A is as defined before with diagonals α and off-diagonals $-\beta$. The Hessian is thus negative definite under the assumption $\beta < \alpha/(n-1) = \alpha$ since $n = 2$. Thus $\overline{\text{ISP}}$ is a concave function of $(p_1^s + p_1^c, p_2^s)$. Similarly $U_{\text{CP},2}$ is strictly concave in p_2^c . An equilibrium with strictly positive demand must satisfy the first-order conditions as before which can be shown to yield

$$\begin{bmatrix} p_1^s + p_1^c \\ p_2^s \\ p_2^c \end{bmatrix} = \begin{bmatrix} 0 & -1/2 & 0 \\ -1 & \tau/6 & 1/3 \\ 1 & -\tau/3 & -2/3 \end{bmatrix} \cdot \begin{bmatrix} p_2^d \\ p_1^a \\ p_2^a \end{bmatrix} + \frac{D_0}{6\alpha} \begin{bmatrix} 3/(1-\tau) \\ (2+\tau)/(1-\tau) \\ 2 \end{bmatrix}, \quad (11)$$

where $\tau = \beta/\alpha$ and $\tau \in [0, 1)$. The details of these calculations are straightforward and thus omitted. The case when $\tau = 0$ is easily handled as a separated case.

Remarks: 1) From (11), we see that when $\tau \lesssim 1$, the $\overline{\text{ISP}}$ prices $p_1^s + p_1^c$ and p_2^s are high. The price charged by CP 2 remains bounded. This is analogous to the case when there was no exclusive contract.

2) Calculations that compare prices with and without exclusive contracts show that exclusive contract helps both types of interauts if and only if $(2\tau)p_2^a \leq (3-\tau^2)p_1^a + (D_0/\alpha)(3+\tau)$, which holds for a wide range of the above parameters, and in particular when $p_1^a = p_2^a$.

V. DISCUSSION

In this paper, we studied a model of a nonneutral network and investigated the role of bargaining power in identifying side payments. We began with the simple case of a single CP and a single ISP and studied the equilibria when they bargained with each other over the side payment. The bargaining could happen either before they set their prices or afterward. The relative bargaining power of the ISP with respect to the CP was captured by a single real number between 0 and 1. We highlighted several interesting features of the equilibria. If the agents bargain beforehand, there can be zero-demand equilibria, but there is one unique desirable equilibrium with strictly positive demand. The actual amount of the payment that they agree upon is inconsequential to the users, but the mere fact that they agree upon it before-hand (via bargaining) is beneficial to all agents. If the agents bargain afterward, the agents share the revenue in proportion of their bargaining powers. There is a unique equilibrium and it has the desirable feature of a strictly positive demand.

When there are multiple CPs and demand for content i depends only on the content i 's price (sum of CP price and ISP price), then the problem reduces to n separable single-CP single-ISP problems. If the demand for content i is positively correlated with pricing of other contents, then for pre-bargaining, the results are qualitatively similar to the single-CP

single-ISP case. Under a certain condition on the payments, we demonstrated that there is exactly one unique equilibrium that has strictly positive demand for all contents. In this setting, zero-demand equilibria remain to be characterized. For post-bargaining, however, no equilibrium exists unless the prices are forced to lie in a bounded set. This is in contrast to the single-CP single-ISP case. We also provided some comparisons with a case when CP 1 and ISP enter into an exclusive contract.

Some questions remain unaddressed even within the model under study. We are yet to characterize zero demand equilibria (i) in the multi-CP pre-bargaining case, and (ii) in the case when one CP has an exclusive contract with the ISP. The latter case should be extended to more than two CPs. Also, when there are several equilibria, are some preferred over others?

Our model is, needless to say, a mere caricature that captures certain types of interactions between ISPs, CPs, and interauts. The biggest benefit is that it is tractable, as evidenced by the obtained expressions in this paper. The litmus test of its usefulness will be its ability, or otherwise, to explain some observed behavior, even if only qualitatively. Studies in this direction are ongoing. Finally, aspects of investment in infrastructure by the CPs and the ISPs should be brought in to enrich the model. We hope to pursue this in future works.

ACKNOWLEDGMENTS

This project was supported by IFCPAR/CEFIPRA (Indo-French Centre for the Promotion of Advanced Research), Project 4000-IT-1, and the Euro NGI Network of Excellence.

REFERENCES

- [1] E. Altman, P. Bernhard, G. Kesidis, J. Rojas-Mora, and S. Wong, "A study of non-neutral networks," INRIA, INRIA Research Report 00481702, 2010. Will appear in the 3rd Workshop on Economic Traffic Management (ETM), Collocated with 22nd International Teletraffic Congress (ITC 22), September 6 2010, Amsterdam, Netherlands.
- [2] R. Hahn and S. Wallsten, "The economics of net neutrality," *Economists' Voice, The Berkeley Electronic Press*, vol. 3, no. 6, pp. 1–7, Jun. 2006.
- [3] P. Njoroge, A. Ozdaglar, N. Stier-Moses, and G. Weintraub, "Investment in two-sided markets and the net-neutrality debate," Columbia Business School, Decision, Risk, and Operations Working Papers Series DRO-2010-05, Jul. 2010.
- [4] R. T. B. Ma, D. ming Chiu, J. C. S. Lui, V. Misra, and D. Rubenstein, "Interconnecting eyeballs to content: A Shapley value perspective on isp peering and settlement," in *Proceedings of the 3rd International Workshop on Economics of Networked Systems, NetEcon '08*, Seattle, Washington, USA, Aug. 2008, pp. 61–66.
- [5] —, "On cooperative settlement between content, transit and eyeball internet service providers," in *Proceedings of the 2008 ACM CoNEXT Conference - 4th International Conference on Emerging Networking Experiments and Technologies, CoNEXT '08*, Madrid, Spain, Dec. 2008.
- [6] E. Winter, *The Handbook of Game Theory*. ed: R. J. Aumann and S. Hart, North-Holland, 2002, vol. 3, ch. 53: The Shapley value.
- [7] J. F. Nash Jr., "The bargaining problem," *Econometrica*, vol. 18, pp. 155–162, 1950.
- [8] C. Saavedra, "Bargaining power and the net neutrality problem," in *NEREC Research Conference on Electronic Communications, Ecole Polytechnique*, 11–12 Sep. 2009.
- [9] F. P. Kelly, "Charging and rate control for elastic traffic," *European Transactions on Telecommunications*, vol. 8, pp. 33–37, 1997.
- [10] A. P. Azad, E. Altman, and R. El-Azouzi, "From altruism to non-cooperation in routing games," in *Proceedings of the Networking and Electronic Commerce Research Conference (NAEC 2009)*, Lake Garda, Italy, Oct. 2009.